

Welding of Pipelines and Related Facilities

API STANDARD 1104
TWENTIETH EDITION, NOVEMBER 2005



Welding of Pipelines and Related Facilities

Pipeline Segment

API STANDARD 1104
TWENTIETH EDITION, NOVEMBER 2005



SPECIAL NOTES

API publications necessarily address problems of a general nature. With respect to particular circumstances, local, state, and federal laws and regulations should be reviewed.

Neither API nor any of API's employees, subcontractors, consultants, committees, or other assignees make any warranty or representation, either express or implied, with respect to the accuracy, completeness, or usefulness of the information contained herein, or assume any liability or responsibility for any use, or the results of such use, of any information or process disclosed in this publication. Neither API nor any of API's employees, subcontractors, consultants, or other assignees represent that use of this publication would not infringe upon privately owned rights.

API publications may be used by anyone desiring to do so. Every effort has been made by the Institute to assure the accuracy and reliability of the data contained in them; however, the Institute makes no representation, warranty, or guarantee in connection with this publication and hereby expressly disclaims any liability or responsibility for loss or damage resulting from its use or for the violation of any authorities having jurisdiction with which this publication may conflict.

API publications are published to facilitate the broad availability of proven, sound engineering and operating practices. These publications are not intended to obviate the need for applying sound engineering judgment regarding when and where these publications should be utilized. The formulation and publication of API publications is not intended in any way to inhibit anyone from using any other practices.

Any manufacturer marking equipment or materials in conformance with the marking requirements of an API standard is solely responsible for complying with all the applicable requirements of that standard. API does not represent, warrant, or guarantee that such products do in fact conform to the applicable API standard.

All rights reserved. No part of this work may be reproduced, stored in a retrieval system, or transmitted by any means, electronic, mechanical, photocopying, recording, or otherwise, without prior written permission from the publisher. Contact the Publisher, API Publishing Services, 1220 L Street, N.W., Washington, D.C. 20005.

Copyright © 2005 American Petroleum Institute

FOREWORD

This standard was prepared by a formulating committee that included representatives of the American Petroleum Institute, the American Gas Association, the Pipe Line Contractors Association, the American Welding Society, and the American Society for Nondestructive Testing, as well as representatives of pipe manufacturers and individuals associated with related industries.

The purpose of this standard is to present methods for the production of high-quality welds through the use of qualified welders using approved welding procedures, materials, and equipment. Its purpose is also to present inspection methods to ensure the proper analysis of welding quality through the use of qualified technicians and approved methods and equipment. It applies to both new construction and in-service welding.

The use of this standard is entirely voluntary and is intended to apply to welding of piping used in the compression, pumping, and transmission of crude petroleum, petroleum products, fuel gases, carbon dioxide, and nitrogen and, where applicable, to distribution systems.

This standard represents the combined efforts of many engineers who are responsible for the design, construction, and operation of oil and gas pipelines, and the committee appreciatively acknowledges their wholehearted and valuable assistance.

From time to time, revisions of this standard will be necessary to keep current with technological developments. The committee is always anxious to improve this standard and will give full consideration to all comments received.

An appeal of any API standards action by an interested party shall be directed to the API.

Nothing contained in any API publication is to be construed as granting any right, by implication or otherwise, for the manufacture, sale, or use of any method, apparatus, or product covered by letters patent. Neither should anything contained in the publication be construed as insuring anyone against liability for infringement of letters patent.

This document was produced under API standardization procedures that ensure appropriate notification and participation in the developmental process and is designated as an API standard. Questions concerning the interpretation of the content of this publication or comments and questions concerning the procedures under which this publication was developed should be directed in writing to the Director of Standards, American Petroleum Institute, 1220 L Street, N.W., Washington, D.C. 20005. Requests for permission to reproduce or translate all or any part of the material published herein should also be addressed to the director.

Generally, API standards are reviewed and revised, reaffirmed, or withdrawn at least every five years. A one-time extension of up to two years may be added to this review cycle. Status of the publication can be ascertained from the API Standards Department, telephone (202) 682-8000. A catalog of API publications and materials is published annually and updated quarterly by API, 1220 L Street, N.W., Washington, D.C. 20005.

Suggested revisions are invited and should be submitted to the Standards and Publications Department, API, 1220 L Street, NW, Washington, DC 20005, standards@api.org.

API-AGA JOINT COMMITTEE ON OIL AND GAS PIPELINE FIELD WELDING PRACTICES

Robert Wright, Chairman
Marshall L. Farley, Vice-Chairman
Gary G. Perkins, Secretary

American Petroleum Institute

Donald Drake
Damodaran Raghu
Jim Ibarra
Gary G. Perkins

American Gas Association

Marshall L. Farley
Alan C. Holk
Perry N. Sheth
Joseph Sieve

American Society for Nondestructive Testing

David L. Culbertson
C. P. Woodruff, Jr.
Scott M. Metzger
Tom Reeder

American Welding Society

William A. Bruce
Alan S. Beckett
Robert W. Gatlin
Robert R. Wright

National Electrical Manufacturers Association

Ken Lee

Pipe Manufacturers

Frank M. Christensen
Samar K. Saha
Jessie E. Robbins
Robert Wise

Pipeline Contractors Association

Brian Laing
Ronnie F. Wise
Don W. Thorn
Bill Marhofer

General Interest Group

Robert Huntley
Wayne Klemcke
Joel Sprague
Young Yi Wang

Members Emeritus

John K. McCarron
Dale Wilson
M. Jordan Hunter
E. L. Von Rosenberg
R.B. Gwin
H. Charles Price

CONTENTS

	Page
1 GENERAL.....	1
1.1 Scope	1
2 REFERENCED PUBLICATIONS.....	1
3 DEFINITION OF TERMS	2
3.1 General.....	2
3.2 Definitions	2
4 SPECIFICATIONS	2
4.1 Equipment	2
4.2 Materials	3
5 QUALIFICATION OF WELDING PROCEDURES FOR WELDS CONTAINING FILLER-METAL ADDITIVES	3
5.1 Procedure Qualification.....	3
5.2 Record	3
5.3 Procedure Specification.....	3
5.4 Essential Variables	4
5.5 Welding of Test Joints-Butt Welds	7
5.6 Testing of Welded Joints-Butt Welds	7
5.7 Welding of Test Joints-Fillet Welds.....	9
5.8 Testing of Welded Joints-Fillet Welds.....	9
6 QUALIFICATION OF WELDERS	10
6.1 General.....	10
6.2 Single Qualification	10
6.3 Multiple Qualification	14
6.4 Visual Examination	17
6.5 Destructive Testing.....	17
6.6 Radiography Butt-welds Only	19
6.7 Retesting.....	19
6.8 Records.....	19
7 DESIGN AND PREPARATION OF A JOINT FOR PRODUCTION WELDING..	19
7.1 General	19
7.2 Alignment.....	19
7.3 Use of Lineup Clamp for Butt-welds	19
7.4 Bevel.....	20
7.5 Weather Conditions	20
7.6 Clearance	20
7.7 Cleaning Between Beads.....	20
7.8 Position Welding	20
7.9 Roll Welding	20
7.10 Identification of Welds	20
7.11 Pre-and Post-Heat Treatment.....	20
8 INSPECTION AND TESTING OF PRODUCTION WELDS	21
8.1 Rights of Inspection.....	21

	Page	
8.2	Methods of Inspection	21
8.3	Qualification of Inspection Personnel	21
8.4	Certification of Nondestructive Testing Personnel	21
9	ACCEPTANCE STANDARDS FOR NONDESTRUCTIVE TESTING	21
9.1	General	21
9.2	Rights of Rejection	21
9.3	Radiographic Testing	21
9.4	Magnetic Particle Testing	27
9.5	Liquid Penetrant Testing	27
9.6	Ultrasonic Testing	28
9.7	Visual Acceptance Standards for Undercutting	29
10	REPAIR AND REMOVAL OF DEFECTS	29
10.1	Authorization for Repair	29
10.2	Repair Procedure	29
10.3	Acceptance Criteria	29
10.4	Supervision	30
10.5	Welder	30
11	PROCEDURES FOR NONDESTRUCTIVE TESTING	30
11.1	Radiographic Test Methods	30
11.2	Magnetic Particle Test Method	33
11.3	Liquid Penetrant Test Method	33
11.4	Ultrasonic Test Methods	33
12	MECHANIZED WELDING WITH FILLER METAL ADDITIONS	37
12.1	Acceptable Processes	37
12.2	Procedure Qualification	37
12.3	Record	37
12.4	Procedure Specification	37
12.5	Essential Variables	38
12.6	Qualification of Welding Equipment and Operators	39
12.7	Records of Qualified Operators	40
12.8	Inspection And Testing of Production Welds	40
12.9	Acceptance Standards for Nondestructive Testing	40
12.10	Repair and Removal of Defects	40
12.11	Radiographic Testing	40
13	AUTOMATIC WELDING WITHOUT FILLER-METAL ADDITIONS	40
13.1	Acceptable Processes	40
13.2	Procedure Qualification	40
13.3	Record	41
13.4	Procedure Specification	41
13.5	Essential Variables	41
13.6	Qualification of Equipment and Operators	42
13.7	Records of Qualified Operators	42
13.8	Quality Assurance of Production Welds	43
13.9	Acceptance Standards for Nondestructive Testing	46
13.10	Repair and Removal of Defects	46
13.11	Radiographic Procedure	46

APPENDIX A	ALTERNATIVE ACCEPTANCE STANDARDS FOR GIRTH WELDS	47
A.1	General	47
A.2	Additional Requirements for Stress Analysis	47
A.3	Welding Procedure	48
A.4	Qualification of Welders	52
A.5	Inspection and Acceptable Limits	52
A.6	Record	53
A.7	Example	53
A.8	Repairs	57
A.9	Nomenclature	57
APPENDIX B	IN-SERVICE WELDING	59
B.1	General	59
B.2	Qualification of In-service Welding Procedures	59
B.3	In-service Welder Qualification	61
B.4	Suggested In-service Welding Practices	62
B.5	Inspection and Testing of In-service Welds	62
B.6	Standards of Acceptability: Nondestructive Testing (Including Visual)	63
B.7	Repair and Removal of Defects	63

Figures

1	Sample Procedure Specification Form	5
2	Sample Coupon Test Report	6
3	Location of Test Butt-weld Specimens for Procedure Qualification Test	11
4	Tensile-strength Test Specimen	12
5	Nick-break Test Specimen	12
6	Root- and Face-bend Test Specimen: Wall Thicknesses Less Than or Equal to 0.500 in. (12.7 mm)	13
7	Side-bend Test Specimen: Wall Thicknesses Greater than 0.500 in. (12.7 mm)	13
8	Dimensioning of Imperfections in Exposed Weld Surfaces	14
9	Jig for Guided-bend Tests	15
10	Location of Nick-break Test Specimens: Fillet-weld Procedure and Welder Qualification Test Welds	16
11	Location of Nick-break Test Specimens: Fillet-weld Procedure and Welder Qualification Test Welds, Including Size-to-size Branch-connection Welder Qualification Test	16
12	Location of Test Butt-weld Specimens for Welder Qualification Test	18
13	Inadequate Penetration Without High-Low (IP)	22
14	Inadequate Penetration Due to High-low (IPD)	24
15	Inadequate Cross Penetration (ICP)	24
16	Incomplete Fusion at Root of Bead or Top of Joint (IF)	24
17	Incomplete Fusion Due to Cold Lap (IFD)	24
18	Internal Concavity (IC)	24
19	Maximum Distribution of Gas Pockets: Wall Thicknesses Less Than or Equal to 0.500 in. (12.7 mm)	25
20	Maximum Distribution of Gas Pockets: Wall Thicknesses Greater Than 0.500 in. (12.7 mm)	26
21A	Reference Block for Manual UT	35
21B	Establishing Distance, Refracted Angle, and Velocity	36
21C	Transfer Procedure	36

22	Location of Test Butt-weld Specimens for Flash-weld Procedure Qualification Test: Outside Diameter Greater Than 18 in. (457 mm) but Less Than or Equal to 24 in. (610 mm)	42
23	Location of Test Butt-weld Specimens for Flash-weld Procedure Qualification Test: Outside Diameter Greater Than 24 in. (610 mm) but Less Than or Equal to 30 in. (762 mm)	43
24	Location of Test Butt-weld Specimens for Flash-weld Procedure Qualification Test: Outside Diameter Greater Than 30 in. (762 mm)	44
25	Two inch Nick-break Test Specimen	45
A-1	Location of CTOD Test Specimens	49
A-2	Machining Objective for CTOD Test Specimen with Respect to Pipe Wall	49
A-3	Location of Notch for Weld-metal Specimen	50
A-4	Location of Notch for Heat-affected Zone Specimen	50
A-5	Alternative Acceptance Criteria for Circumferential Planar Imperfections.	51
A-6	Criteria for Evaluation of Imperfection Interaction	54
A-7	Length Limit for Deep Imperfections in Heavy-Wall Pipe	56
A-8	Nomenclature for Dimensions of Surface and Buried Imperfections	57
B-1	Examples of Typical Temper-bead Deposition Sequences	60
B-2	Suggested Procedure and Welder Qualification Test Assembly	63
B-3	Location of Test Specimens—In-Service Welding Procedure Qualification Test	64
B-4	Macro Test Specimen—In-service Welds	65
B-5	Face-bend Test Specimen	65
B-6	Reinforcing Pad	66
B-7	Reinforcing Saddle	66
B-8	Encirclement Sleeve	67
B-9	Encirclement Tee	67
B-10	Encirclement Sleeve and Saddle	68
B-11	Encirclement Saddle	68

Tables

1	Filler Metal Groups	8
2	Type and Number of Test Specimens for Procedure Qualification Test	10
3	Type and Number of Butt-weld Test Specimens per Welder for Welder Qualification Test and Destructive Testing of Production Welds	19
4	Maximum Dimensions of Undercutting	30
5	Weld Thickness Versus Diameter of ASTM E 747 Wire Type IQI	33
6	Weld Thickness Versus Diameter of ISO Wire Type IQI	33
7	Type and Number of Test Specimens for Procedure Qualification Test (Flash Weld Only)	40
A-1	Acceptance Limits for Buried Volumetric Imperfections	52
A-2	Acceptance Limits for Unrepaired Arc Burns	55
A-3	Imperfection Length Limits	55
A-4	Allowable Imperfection Dimensions for Example	56
A-5	Acceptable Planar Imperfection Dimensions for Example	56
A-6	Example Alternative Acceptance Criteria	57
B-1	Type and Number of Specimens—In-Service Welding Procedure Qualification Test	64
B-2	Type and Number of Test Specimens for Longitudinal Seam Welds—Welder Qualification Test	65

Welding of Pipelines and Related Facilities

1 General

1.1 SCOPE

This standard covers the gas and arc welding of butt, fillet, and socket welds in carbon and low-alloy steel piping used in the compression, pumping, and transmission of crude petroleum, petroleum products, fuel gases, carbon dioxide, nitrogen and, where applicable, covers welding on distribution systems. It applies to both new construction and in-service welding. The welding may be done by a shielded metal-arc welding, submerged arc welding, gas tungsten-arc welding, gas metal-arc welding, flux-cored arc welding, plasma arc welding, oxyacetylene welding, or flash butt welding process or by a combination of these processes using a manual, semi-automatic, mechanized, or automatic welding technique or a combination of these techniques. The welds may be produced by position or roll welding or by a combination of position and roll welding.

This standard also covers the procedures for radiographic, magnetic particle, liquid penetrant, and ultrasonic testing, as well as the acceptance standards to be applied to production welds tested to destruction or inspected by radiographic, magnetic particle, liquid penetrant, ultrasonic, and visual testing methods.

The values stated in either inch-pound units or SI units are to be regarded separately as standard. Each system is to be used independently of the other, without combining values in any way.

Processes other than those described above will be considered for inclusion in this standard. Persons who wish to have other processes included shall submit, as a minimum, the following information for the committee's consideration:

- a. A description of the welding process.
- b. A proposal on the essential variables.
- c. A welding procedure specification.
- d. Weld inspection methods.
- e. Types of weld imperfections and their proposed acceptance limits.
- f. Repair procedures.

It is intended that all work performed in accordance with this standard shall meet or exceed the requirements of this standard.

2 Referenced Publications

The following standards, codes, and specifications are cited in this standard:

API

Spec 5L *Specification for Line Pipe*

RP 2201 *Safe Hot Tapping Practices in the Petroleum & Petrochemical Industries*

ASNT¹

RP SNT-TC-1A *Personnel Qualification and Certification in Nondestructive Testing*
ACCP *ASNT Central Certification Program*

ASTM²

E 164 *Standard Practice for Ultrasonic Contact Examination of Weldments*
E 165 *Standard Test Methods for Liquid Penetrant Examination*
E 709 *Standard Guide for Magnetic Particle Examination*
E 747 *Standard Practice for Design, Manufacture and Material Grouping Classification of Wire Image Quality Indicators (IQI) Used for Radiology*

AWS³

A3.0 *Welding, Terms and Definitions*
A5.1 *Covered Carbon Steel Arc Welding Electrodes*
A5.2 *Iron and Steel Oxyfuel Gas Welding Rods*
A5.5 *Low Alloy Steel Covered Arc Welding Electrodes*
A5.17 *Carbon Steel Electrodes and Fluxes for Submerged Arc Welding*
A5.18 *Carbon Steel Filler Metals for Gas Shielded Arc Welding*
A5.20 *Carbon Steel Electrodes for Flux Cored Arc Welding*
A5.28 *Low Alloy Steel Filler Metals for Gas Shielded Arc Welding*
A5.29 *Low Alloy Steel Electrodes for Flux Cored Arc Welding*

BSI⁴

BS 7448:
Pt. 2 *Fracture Mechanics Toughness Tests Part 2, Method for Determination of K_{Ic} Critical*

¹American Society for Nondestructive Testing, Inc., 1711 Arlington Lane, P.O. Box 28518, Columbus, Ohio 43228-0518. www.asnt.org

²American Society for Testing and Materials, P.O. Box C700, 100 Barr Harbor Drive, West Conshohocken, Pennsylvania 19428-2959. www.astm.org

³American Welding Society, 550 N.W. LeJeune Road, Miami, Florida 33126. www.aws.org

⁴BSI, British Standards HQ, 389 Chiswick High Road, London, W4 4AL, United Kingdom. www.bsi-global.com

CTOD and Critical J Values of Welds in Metallic Materials

ISO⁵

ISO 1027 *Radiographic image quality indicators for non-destructive testing—Principles and Identification*

NACE⁶

MR0175 *Sulfide Stress Cracking Resistant Metallic Materials for Oil Field Equipment*

3 Definition of Terms

3.1 GENERAL

The welding terms used in this standard are as defined in AWS A3.0, with the additions and modifications given in 3.2.

3.2 DEFINITIONS

3.2.1 automatic welding: Arc welding with equipment that performs the entire welding operation without manual manipulation of the arc or electrode other than guiding or tracking and without a manual welding-skill requirement of the operator.

3.2.2 branch weld: The completed weld joining a branch pipe or branch fitting to a run pipe.

3.2.3 company: The owner company or the engineering agency in charge of construction. The company may act through an inspector or another authorized representative.

3.2.4 contractor: Includes the primary contractor and any subcontractors engaged in work covered by this standard.

3.2.5 defect: An imperfection of sufficient magnitude to warrant rejection based on the stipulations in this standard.

3.2.6 imperfection: A discontinuity or irregularity that is detectable by methods outlined in this standard.

3.2.7 indication: Evidence obtained by nondestructive testing.

3.2.8 internal concavity: A bead that is properly fused to and completely penetrates the pipe wall thickness along both sides of the bevel, but whose center is somewhat below the inside surface of the pipe wall. The magnitude of concavity is the perpendicular distance between an axial extension of the pipe wall surface and the lowest point on the weld bead surface.

⁵International Organization for Standardization (ISO), 1, rue de Varembé, Case postale 56, CH-1211 Geneva 20, Switzerland. www.iso.org

⁶NACE International, 1440 South Creek Drive, Houston, Texas 77084-4906. www.nace.org

3.2.9 mechanized welding: A process where parameters and torch guidance are controlled mechanically or electronically but may be manually varied during welding to maintain the specified welding conditions.

3.2.10 position welding: Welding in which the pipe or assembly is not rotating while the weld is being deposited.

3.2.11 qualified welder: A welder who has demonstrated the ability to produce welds that meet the requirements of Sections 5 or 6.

3.2.12 qualified welding procedure: A tested and proven detailed method by which sound welds with suitable mechanical properties can be produced.

3.2.13 radiographer: A person who performs radiographic operations.

3.2.14 repair: Any rework on a completed weld that requires welding to correct a fault in the weld that has been discovered by visual or nondestructive testing and is beyond this standard's limits of acceptability.

3.2.15 roll welding: Welding in which the pipe or assembly is rotated while the weld metal is being deposited at or near the top center.

3.2.16 root bead: The first or stringer bead that initially joins two sections of pipe, a section of pipe to a fitting, or two fittings.

3.2.17 semiautomatic welding: Arc welding with equipment that controls only the filler-metal feed. The advance of the welding is manually controlled.

3.2.18 shall: Term that indicates a mandatory requirement. The term should indicate a recommended practice.

3.2.19 weld: The completed weld joining two sections of pipe, a section of pipe to a fitting, or two fittings.

3.2.20 welder: A person who makes a weld.

4 Specifications

4.1 EQUIPMENT

Welding equipment, both gas and arc, shall be of a size and type suitable for the work and shall be maintained in a condition that ensures acceptable welds, continuity of operation, and safety of personnel. Arc-welding equipment shall be operated within the amperage and voltage ranges given in the qualified welding procedure. Gas-welding equipment shall be operated with the flame characteristics and tip sizes given in the qualified welding procedure. Equipment that does not meet these requirements shall be repaired or replaced.

4.2 MATERIALS

4.2.1 Pipe and Fittings

This standard applies to the welding of pipe and fittings that conform to the following specifications:

- a. API Spec 5L.
- b. Applicable ASTM specifications.

This standard also applies to materials with chemical and mechanical properties that comply with one of the specifications listed in items a and b above, even though the material is not manufactured in accordance with the specification.

4.2.2 Filler Metal

4.2.2.1 Type and Size

All filler metals shall conform to one of the following:

- a. AWS A5.1
- b. AWS A5.2
- c. AWS A5.5
- d. AWS A5.17
- e. AWS A5.18
- f. AWS A5.20
- g. AWS A5.28
- h. AWS A5.29
- i. Filler metals that do not conform to the specifications above may be used provided the welding procedures involving their use are qualified.

4.2.2.2 Storage and Handling of Filler Metals and Fluxes

Filler metals and fluxes shall be stored and handled to avoid damage to them and to the containers in which they are shipped. Filler metals and fluxes in opened containers shall be protected from deterioration, and filler metals that are coated shall be protected from excessive changes in moisture. Filler metals and fluxes that show signs of damage or deterioration shall not be used.

4.2.3 Shielding Gases

4.2.3.1 Types

Atmospheres for shielding an arc are of several types and may consist of inert gases, active gases, or mixtures of inert and active gases. The purity and dryness of these atmospheres have great influence on welding and should be of values suitable for the process and the materials to be welded. The shielding atmosphere to be used shall be qualified for the material and the welding process.

4.2.3.2 Storage and Handling

Shielding gases shall be kept in the containers in which they are supplied, and the containers shall be stored away from extremes of temperature. Gases shall not be field intermixed in their containers. Gases of questionable purity and those in containers that show signs of damage shall not be used.

5 Qualification of Welding Procedures for Welds Containing Filler-metal Additives

5.1 PROCEDURE QUALIFICATION

Before production welding is started, a detailed procedure specification shall be established and qualified to demonstrate that welds with suitable mechanical properties (such as strength, ductility, and hardness) and soundness can be made by the procedure. The quality of the welds shall be determined by destructive testing. These procedures shall be adhered to except where a change is specifically authorized by the company, as provided for in 5.4.

5.2 RECORD

The details of each qualified procedure shall be recorded. The record shall show complete results of the procedure qualification test. Forms similar to those shown in Figures 1 and 2 should be used. The record shall be maintained as long as the procedure is in use.

5.3 PROCEDURE SPECIFICATION

5.3.1 General

The procedure specification shall include the information specified in 5.3.2, where applicable.

5.3.2 Specification Information

5.3.2.1 Process

The specific process or combination of processes used shall be identified. The use of a manual, semiautomatic, mechanized, or automatic welding process or any combination of these shall be specified.

5.3.2.2 Pipe and Fitting Materials

The materials to which the procedure applies shall be identified. API Spec 5L pipe, as well as materials that conform to acceptable ASTM specifications, may be grouped (see 5.4.2.2), provided that the qualification test is made on the material with the highest specified minimum yield strength in the group.

5.3.2.3 Diameters and Wall Thicknesses

The ranges of outside diameters and wall thicknesses over which the procedure is applicable shall be identified. Examples of suggested groupings are shown in 6.2.2, items d and e.

5.3.2.4 Joint Design

The specification shall include a sketch or sketches of the joint that show the angle of bevel, the size of the root face, and the root opening or the space between abutting members. The shape and size of fillet welds shall be shown. If a backup is used, the type shall be designated.

5.3.2.5 Filler Metal and Number of Beads

The sizes and classification number of the filler metal and the minimum number and sequence of beads shall be designated.

5.3.2.6 Electrical Characteristics

The current and polarity shall be designated, and the range of voltage and amperage for each electrode, rod, or wire shall be shown.

5.3.2.7 Flame Characteristics

The specification shall designate whether the flame is neutral, carburizing, or oxidizing. The size of the orifice in the torch tip for each size of rod or wire shall be specified.

5.3.2.8 Position

The specification shall designate roll or position welding.

5.3.2.9 Direction of Welding

The specification shall designate whether the welding is to be performed in an uphill or downhill direction.

5.3.2.10 Time between Passes

The maximum time between the completion of the root bead and the start of the second bead, as well as the maximum time between the completion of the second bead and the start of other beads, shall be designated.

5.3.2.11 Type and Removal of Lineup Clamp

The specification shall designate whether the lineup clamp is to be internal or external or if no clamp is required. If a clamp is used, the minimum percentage of root-bead welding that must be completed before the clamp is released shall be specified.

5.3.2.12 Cleaning and/or Grinding

The specification shall indicate whether power tools or hand tools are to be used for cleaning, grinding, or both.

5.3.2.13 Pre- and Post-heat Treatment

The methods, temperature, temperature-control methods, and ambient temperature range for pre- and post-heat treatment shall be specified (see 7.11).

5.3.2.14 Shielding Gas and Flow Rate

The composition of the shielding gas and the range of flow rates shall be designated.

5.3.2.15 Shielding Flux

The type of shielding flux shall be designated.

5.3.2.16 Speed of Travel

The range for speed of travel, in inches (millimeters) per minute, shall be specified for each pass.

5.4 ESSENTIAL VARIABLES

5.4.1 General

A welding procedure must be re-established as a new procedure specification and must be completely requalified when any of the essential variables listed in 5.4.2 are changed. Changes other than those given in 5.4.2 may be made in the procedure without the need for requalification, provided the procedure specification is revised to show the changes.

5.4.2 Changes Requiring Requalification

5.4.2.1 Welding Process or Method of Application

A change from the welding process or method of application established in the procedure specification (see 5.3.2.1) constitutes an essential variable.

Reference: API Standard 1104, 5.2

PROCEDURE SPECIFICATION NO. _____

For _____ Welding of _____ Pipe and fittings

Process _____

Material _____

Pipe outside diameter and wall thickness _____

Joint design _____

Filler metal and no. of beads _____

Electrical or flame characteristics _____

Position _____

Direction of welding _____

No. of welders _____

Time lapse between passes _____

Type and removal of lineup clamp _____

Cleaning and/or grinding _____

Preheat/stress relief _____

Shielding gas and flow rate _____

Shielding flux _____

Speed of travel _____ Plasma gas flow rate _____

Plasma gas composition _____

Plasma gas orifice size _____

Sketches and tabulations attached _____

Tested _____

Welder _____

Approved _____

Welding supervisor _____

Adopted _____

Chief engineer _____

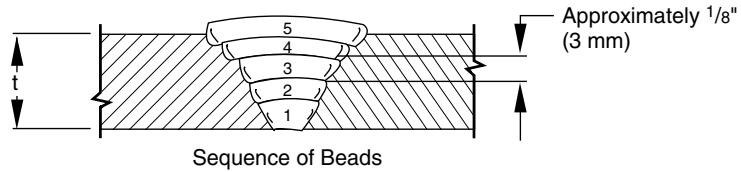
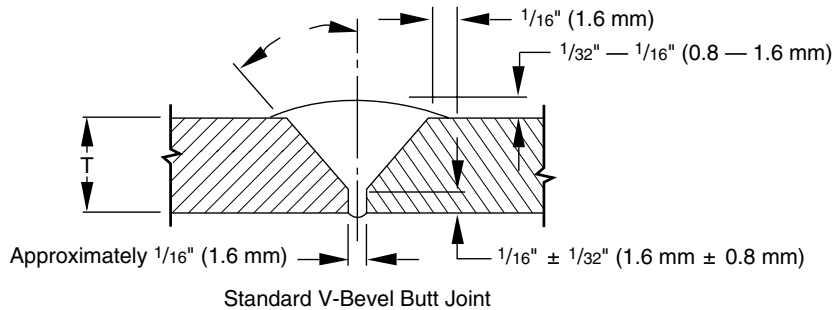

Note: Dimensions are for example only.

ELECTRODE SIZE AND NUMBER OF BEADS

Bead Number	Electrode Size and Type	Voltage	Amperage and Polarity	Speed

Figure 1—Sample Procedure Specification Form

COUPON TEST REPORT							
Date _____				Test No. _____			
Location _____				Weld Position: _____			
State _____		Roll <input type="checkbox"/>		Fixed <input type="checkbox"/>			
Welder _____				Mark _____			
Welding time _____				Time of day _____			
Mean temperature _____				Wind break used _____			
Weather conditions _____				Amperage _____			
Voltage _____				Welding machine size _____			
Welding machine type _____				Filler metal _____			
Reinforcement size _____				Pipe type and grade _____			
Pipe type and grade _____				Wall thickness _____			
Wall thickness _____				Outside diameter _____			
	1	2	3	4	5	6	7
Coupon stenciled							
Original specimen dimensions							
Original specimen area							
Maximum load							
Tensile strength							
Fracture location							
<input type="checkbox"/> Procedure		<input type="checkbox"/> Qualifying test		<input type="checkbox"/> Qualified			
<input type="checkbox"/> Welder		<input type="checkbox"/> Line test		<input type="checkbox"/> Disqualified			
Maximum tensile _____		Minimum tensile _____		Average tensile _____			
Remarks on tensile-strength tests _____							
1. _____							
2. _____							
3. _____							
4. _____							
Remarks on bend tests _____							
1. _____							
2. _____							
3. _____							
4. _____							
Remarks on nick-break tests _____							
1. _____							
2. _____							
3. _____							
4. _____							
Test made at _____				Date _____			
Tested by _____				Supervised by _____			
Note: Use back for additional remarks. This form can be used to report either a procedure qualification test or a welder qualification test.							

Figure 2—Sample Coupon Test Report

5.4.2.2 Base Material

A change in base material constitutes an essential variable. When welding materials of two separate material groups, the procedure for the higher strength group shall be used. For the purposes of this standard, all materials shall be grouped as follows:

- a. Specified minimum yield strength less than or equal to 42,000 psi (290 MPa).
- b. Specified minimum yield strength greater than 42,000 psi (290 MPa) but less than 65,000 psi (448 MPa).
- c. For materials with a specified minimum yield strength greater than or equal to 65,000 psi (448 MPa), each grade shall receive a separate qualification test.

Note: The groupings specified in 5.4.2.2 do not imply that base materials or filler metals of different analyses within a group may be indiscriminately substituted for a material that was used in the qualification test without consideration of the compatibility of the base materials and filler metals from the standpoint of metallurgical and mechanical properties and requirements for pre- and post-heat treatment.

5.4.2.3 Joint Design

A major change in joint design (for example, from V groove to U groove) constitutes an essential variable. Minor changes in the angle of bevel or the land of the welding groove are not essential variables.

5.4.2.4 Position

A change in position from roll to fixed, or vice versa, constitutes an essential variable.

5.4.2.5 Wall Thickness

A change from one wall thickness group to another constitutes an essential variable.

5.4.2.6 Filler Metal

The following changes in filler metal constitute essential variables:

- a. A change from one filler-metal group to another (see Table 1).
- b. For pipe materials with a specified minimum yield strength greater than or equal to 65,000 psi (448 MPa), a change in the AWS classification of the filler metal (see 5.4.2.2).

Changes in filler metal within filler metal groups may be made within the material groups specified in 5.4.2.2. The compatibility of the base material and the filler metal should be considered from the standpoint of mechanical properties.

5.4.2.7 Electrical Characteristics

A change from DC electrode positive to DC electrode negative or vice versa or a change in current from DC to AC or vice versa constitutes an essential variable.

5.4.2.8 Time between Passes

An increase in the maximum time between completion of the root bead and the start of the second bead constitutes an essential variable.

5.4.2.9 Direction of Welding

A change in the direction of welding from vertical downhill to vertical uphill, or vice versa, constitutes an essential variable.

5.4.2.10 Shielding Gas and Flow Rate

A change from one shielding gas to another or from one mixture of gases to another constitutes an essential variable. A major increase or decrease in the range of flow rates for the shielding gas also constitutes an essential variable.

5.4.2.11 Shielding Flux

Refer to Table 1, Footnote a, for changes in shielding flux that constitute essential variables.

5.4.2.12 Speed of Travel

A change in the range for speed of travel constitutes an essential variable.

5.4.2.13 Pre-heat

A decrease in the specified minimum pre-heat temperature constitutes an essential variable.

5.4.2.14 Post-weld Heat Treatment (PWHT)

The addition of PWHT or a change from the ranges or values specified in the procedure shall each constitute an essential variable.

5.5 WELDING OF TEST JOINTS-BUTT WELDS

To weld the test joint for butt welds, two pipe nipples shall be joined, following all the details of the procedure specification.

5.6 TESTING OF WELDED JOINTS-BUTT WELDS

5.6.1 Preparation

To test the butt-welded joint, test specimens shall be cut from the joint at the locations shown in Figure 3. (See Section 13 for testing requirements for the flash welding proce-

Table 1—Filler Metal Groups

Group	AWS Specification	Electrode	Flux ^c
1	A5.1	E6010, E6011	
	A5.5	E7010, E7011	
2	A5.5	E8010, E8011 E9010	
3	A5.1 or A5.5	E7015, E7016, E7018	
	A5.5	E8015, E8016, E8018 E9018	
4 ^a	A5.17	EL8 EL8K EL12 EM5K EM12K EM13K EM15K	P6XZ F6X0 F6X2 F7XZ F7X0 F7X2
5 ^b	A5.18	ER70S-2	
	A5.18	ER70S-6	
	A5.28	ER80S-D2	
	A5.28	ER90S-G	
6	A5.2	RG60, RG65	
7	A5.20	E61T-GS ^d	
		E71T-GS ^d	
8	A5.29	E71T8-K6	
9	A5.29	E91T8-G	

Note: Other electrodes, filler metals, and fluxes may be used but require separate procedure qualification.

^a Any combination of flux and electrode in Group 4 may be used to qualify a procedure. The combination shall be identified by its complete AWS classification number, such as F7A0-EL12 or F6A2-EM12K. Only substitutions that result in the same AWS classification number are permitted without requalification.

^b A shielding gas (see 5.4.2.10) shall be used with the electrodes in Group 5.

^c In the flux designation, the X can be either an A or P for As welded or Post-weld Heat-treated.

^d For root-pass welding only.

duration.) The minimum number of test specimens and the tests to which they shall be subjected are given in Table 2. The specimens shall be prepared as shown in Figure 4, 5, 6, or 7. For pipe less than 2.375 in. (60.3 mm) in outside diameter, two test welds shall be performed to obtain the required number of test specimens. The specimens shall be air cooled to ambient temperature prior to being tested. For pipe less than

or equal to 1.315 in. (33.4 mm) in outside diameter, one full-section specimen may be substituted for the four reduced-section Nick-break and root-bend specimens. The full-section specimen shall be tested in accordance with 5.6.2.2 and shall meet the requirements of 5.6.2.3.

5.6.2 Tensile-strength Test

5.6.2.1 Preparation

The tensile-strength test specimens (see Figure 4) shall be approximately 9 in. (230 mm) long and approximately 1 in. (25 mm) wide. They may be machine cut or oxygen cut, and no other preparation is needed unless the sides are notched or are not parallel. If necessary, the specimens shall be machined so that the sides are smooth and parallel.

5.6.2.2 Method

The tensile-strength test specimens shall be broken under tensile load using equipment capable of measuring the load at which failure occurs. The tensile strength shall be computed by dividing the maximum load at failure by the smallest cross-sectional area of the specimen, as measured before the load is applied.

5.6.2.3 Requirements

The tensile strength of the weld, including the fusion zone of each specimen, shall be greater than or equal to the specified minimum tensile strength of the pipe material but need not be greater than or equal to the actual tensile strength of the material. If the specimen breaks outside the weld and fusion zone (that is, in the parent pipe material) and meets the minimum tensile-strength requirements of the specification, the weld shall be accepted as meeting the requirements.

If the specimen breaks in the weld or fusion zone and the observed strength is greater than or equal to the specified minimum tensile strength of the pipe material and meets the soundness requirements of 5.6.3.3, the weld shall be accepted as meeting the requirements.

If the specimen breaks below the specified minimum tensile strength of the pipe material, the weld shall be set aside and a new test weld shall be made.

5.6.3 Nick-break Test

5.6.3.1 Preparation

The Nick-break test specimens (see Figure 5) shall be approximately 9 in. (230 mm) long and approximately 1 in. (25 mm) wide and may be machine cut or oxygen cut. They shall be notched with a hacksaw on each side at the center of the weld, and each notch shall be approximately 1/8 in. (3 mm) deep.

Nick-break specimens prepared in this manner from welds made with certain mechanized and semiautomatic processes may fail through the pipe instead of the weld. When previous testing experience indicates that failures through the pipe can be expected, the external reinforcement may be notched to a depth of not more than $1/16$ in. (1.6 mm), measured from the original weld surface.

At the company's option, Nick-break specimens for qualification of a procedure using a semiautomatic or mechanized welding process may be macro-etched prior to being nicked.

5.6.3.2 Method

The Nick-break specimens shall be broken by pulling in a tensile machine, by supporting the ends and striking the center, or by supporting one end and striking the other end with a hammer. The exposed area of the fracture shall be at least $3/4$ in. (19 mm) wide.

5.6.3.3 Requirements

The exposed surfaces of each Nick-break specimen shall show complete penetration and fusion. The greatest dimension of any gas pocket shall not exceed $1/16$ in. (1.6 mm), and the combined area of all gas pockets shall not exceed 2% of the exposed surface area. Slag inclusions shall not be more than $1/32$ in. (0.8 mm) in depth and shall not be more than $1/8$ in. (3 mm) or one-half the nominal wall thickness in length, whichever is smaller. There shall be at least $1/2$ in. (13 mm) separation between adjacent slag inclusions. The dimensions should be measured as shown in Figure 8. Fisheyes, as defined in AWS A3.0, are not cause for rejection.

5.6.4 Root- and Face-bend Test

5.6.4.1 Preparation

The root- and face-bend test specimens (see Figure 6) shall be approximately 9 in. (230 mm) long and approximately 1 in. (25 mm) wide, and their long edges shall be rounded. They may be machine cut or oxygen cut. The cover and root-bead reinforcements shall be removed flush with the surfaces of the specimen. These surfaces shall be smooth, and any scratches that exist shall be light and transverse to the weld.

5.6.4.2 Method

The root- and face-bend specimens shall be bent in a guided-bend test jig similar to that shown in Figure 9. Each specimen shall be placed on the die with the weld at mid span. Face-bend specimens shall be placed with the face of the weld toward the gap, and root-bend specimens shall be placed with the root of the weld toward the gap. The plunger shall be forced into the gap until the curvature of the specimen is approximately U-shaped.

5.6.4.3 Requirements

The bend test shall be considered acceptable if no crack or other imperfection exceeding $1/8$ in. (3 mm) or one-half the nominal wall thickness, whichever is smaller, in any direction is present in the weld or between the weld and the fusion zone after bending. Cracks that originate on the outer radius of the bend along the edges of the specimen during testing and that are less than $1/4$ in. (6 mm), measured in any direction, shall not be considered unless obvious imperfections are observed. Each specimen subjected to the bend test shall meet these requirements.

5.6.5 Side-bend Test

5.6.5.1 Preparation

The side-bend test specimens (see Figure 7) shall be approximately 9 in. (230 mm) long and approximately $1/2$ in. (13 mm) wide, and their long edges shall be rounded. They shall be machine cut, or they may be oxygen cut to approximately a $3/4$ in. (19 mm) width and then machined or ground to the $1/2$ in. (13 mm) width. The sides shall be smooth and parallel. The cover and root-bead reinforcements shall be removed flush with the surfaces of the specimen.

5.6.5.2 Method

The side-bend specimens shall be bent in a guided-bend test jig similar to that shown in Figure 9. Each specimen shall be placed on the die with the weld at mid span and with the face of the weld perpendicular to the gap. The plunger shall be forced into the gap until the curvature of the specimen is approximately U-shaped.

5.6.5.3 Requirements

Each side-bend specimen shall meet the root- and face-bend test requirements specified in 5.6.4.3.

5.7 WELDING OF TEST JOINTS-FILLET WELDS

To weld the test joint for a fillet weld, a fillet weld shall be made to one of the configurations shown in Figure 10, following all the details of the procedure specification.

5.8 TESTING OF WELDED JOINTS-FILLET WELDS

5.8.1 Preparation

To test the fillet-welded joint, test specimens shall be cut from the joint at the locations shown in Figure 10. At least four specimens shall be taken and prepared as shown in Figure 11. The specimens may be machine cut or oxygen cut. They should be at least 1 in. (25 mm) wide and long enough so that they can be broken in the weld. For pipes less than 2.375 in. (60.3 mm) in outside diameter, it may be necessary

Table 2—Type and Number of Test Specimens for Procedure Qualification Test

Outside Diameter of Pipe		Number of Specimens					
Inches	Millimeters	Tensile Strength	Nick-break	Root Bend	Face Bend	Side Bend	Total
Wall Thickness ≤ 0.500 in. (12.7 mm)							
< 2.375	< 60.3	0 ^b	2	2	0	0	4 ^a
2.375 – 4.500	60.3 – 114.3	0 ^b	2	2	0	0	4
> 4.500 – 12.750	>114.3 – 323.9	2	2	2	2	0	8
> 12.750	> 323.9	4	4	4	4	0	16
Wall Thickness > 0.500 in. (12.7 mm)							
≤ 4.500	≤ 114.3	0 ^b	2	0	0	2	4
> 4.500 – 12.750	>114.3 – 323.9	2	2	0	0	4	8
> 12.750	> 323.9	4	4	0	0	8	16

^a One Nick-break and one root-bend specimen shall be taken from each of two test welds, or for pipe less than or equal to 1.315 in. (33.4 mm) in diameter, one full-section tensile-strength specimen shall be taken.

^b For materials with specified minimum yield strengths greater than 42,000 psi (290 MPa), a minimum of one tensile test shall be required.

to make two test welds to obtain the required number of test specimens. The specimens shall be air cooled to ambient temperature prior to testing.

5.8.2 Method

The fillet-weld specimens shall be broken in the weld by any convenient method.

5.8.3 Requirements

The exposed surfaces of each fillet-weld specimen shall show complete penetration and fusion, and a) the greatest dimension of any gas pocket shall not exceed $1/16$ in. (1.6 mm), b) the combined area of all gas pockets shall not exceed 2% of the exposed surface area, c) slag inclusions shall not be more than $1/32$ in. (0.8 mm) in depth and shall not be more than $1/8$ in. (3 mm) or one-half the nominal wall thickness in length, whichever is smaller, and d) there shall be at least $1/2$ in. (13 mm) separation between adjacent slag inclusions. The dimensions should be measured as shown in Figure 8.

6 Qualification of Welders

6.1 GENERAL

The purpose of the welder qualification test is to determine the ability of welders to make sound butt or fillet welds using previously qualified procedures. Before any production welding is performed, welders shall be qualified according to the applicable requirements of 6.2 through 6.8. It is the intent of this standard that a welder who satisfactorily completes the procedure qualification test is a qualified welder, provided the number of test specimens required by 6.5 have been removed, tested, and meet the acceptance criteria of 5.6, for each welder.

Prior to starting the qualification tests, the welder shall be allowed reasonable time to adjust the welding equipment to

be used. The welder shall use the same welding technique and proceed with the same speed he will use if he passes the test and is permitted to do production welding. The qualification of welders shall be conducted in the presence of a representative acceptable to the company.

A welder shall qualify for welding by performing a test on segments of pipe nipples or on full-size pipe nipples, as specified in 6.2.1. When segments of pipe nipples are used, they shall be supported so that typical flat, vertical, and overhead welds are produced.

The essential variables associated with procedure and welder qualifications are not identical. The essential variables for welder qualification are specified in 6.2.2 and 6.3.2.

6.2 SINGLE QUALIFICATION

6.2.1 General

For single qualification, a welder shall make a test weld using a qualified procedure to join pipe nipples or segments of pipe nipples. The welder shall make a butt weld in either the rolled or the fixed position. When the welder is qualifying in the fixed position, the axis of the pipe shall be in the horizontal plane, in the vertical plane, or inclined from the horizontal plane at an angle of not more than 45°.

A welder making a single-qualification test for branch connections, fillet welds, or other similar configurations shall follow the specific procedure specification.

Changes in the essential variables described in 6.2.2 require requalification of the welder.

The weld shall be acceptable if it meets the requirements of 6.4 and either 6.5 or 6.6.

6.2.2 Scope

A welder who has successfully completed the qualification test described in 6.2.1 shall be qualified within the limits of

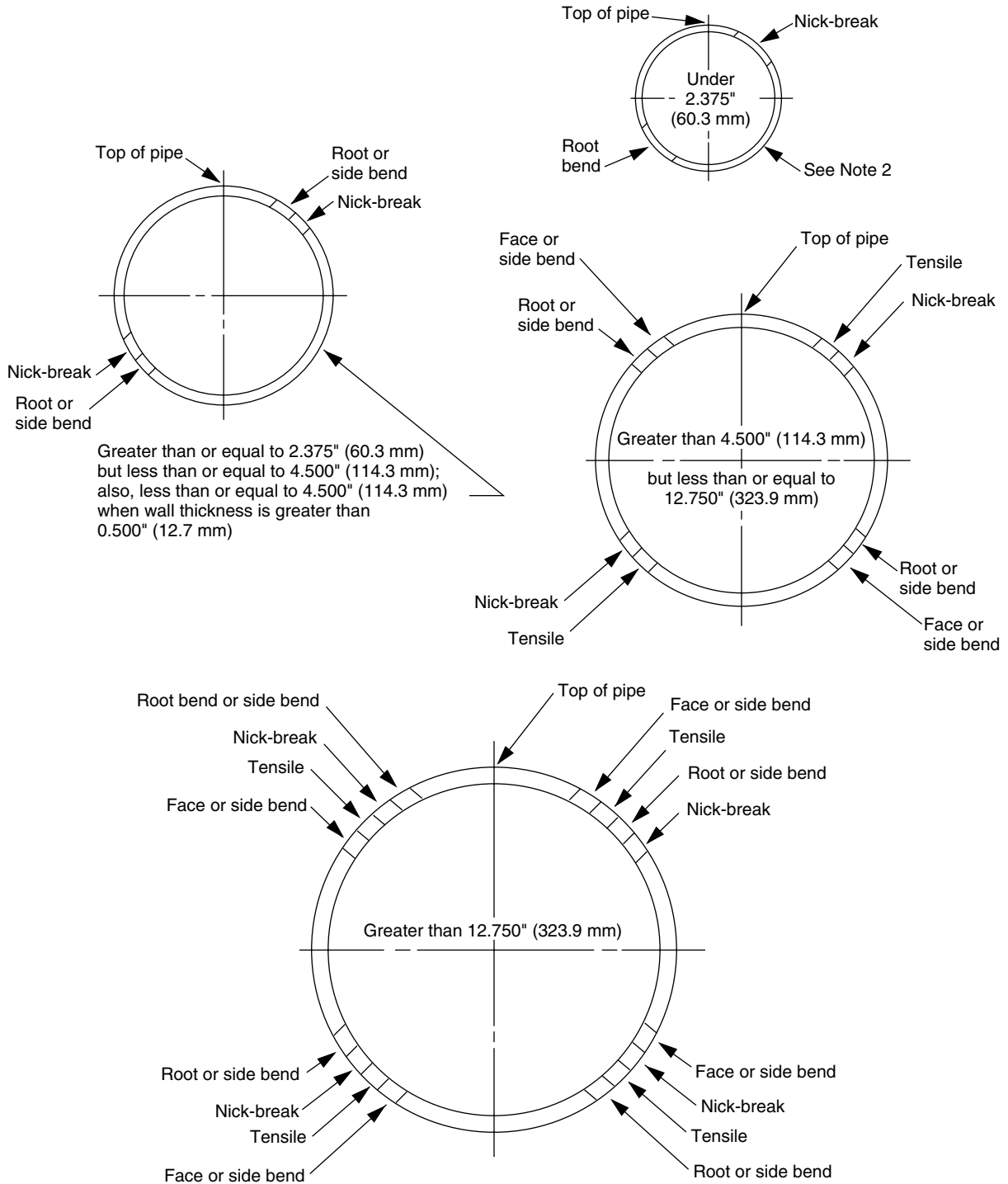

Notes:

1. At the company's option, the locations may be rotated, provided they are equally spaced around the pipe; however, specimens shall not include the longitudinal weld.
2. One full-section tensile specimen may be used for pipe with an outside diameter less than or equal to 1.315 in. (33.4 mm).

Figure 3—Location of Test Butt-weld Specimens for Procedure Qualification Test

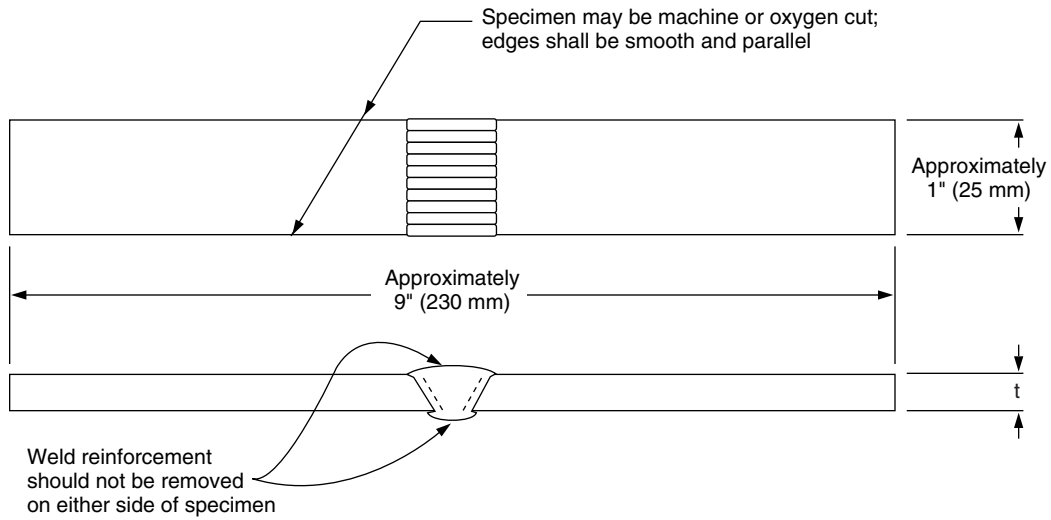

Figure 4—Tensile-strength Test Specimen

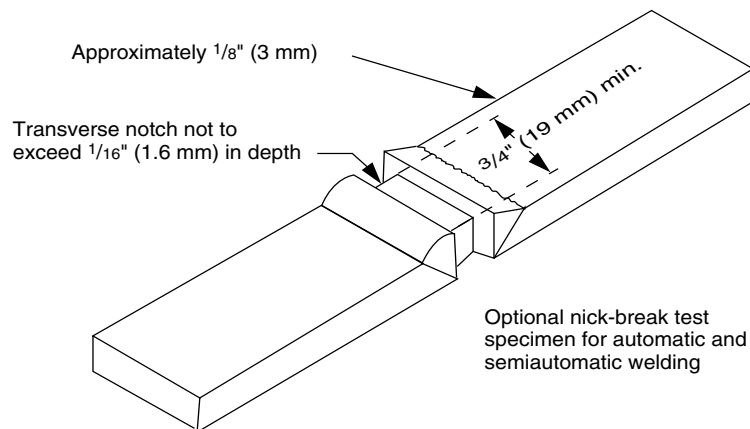
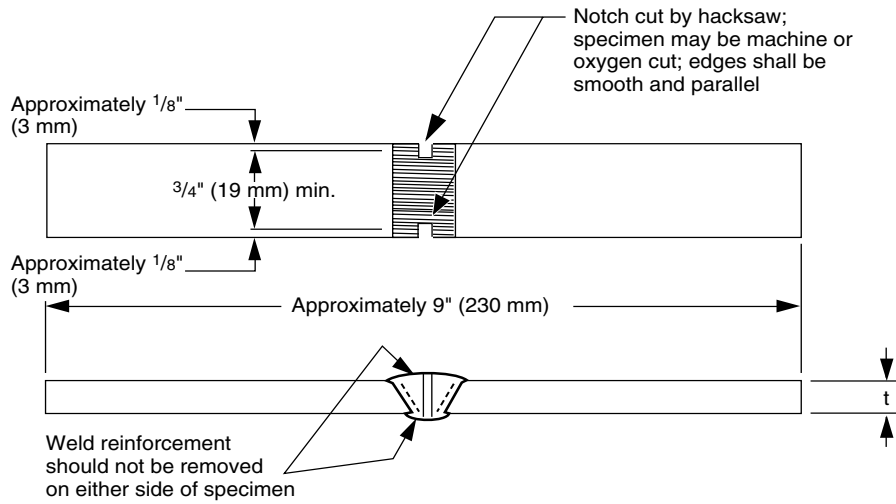
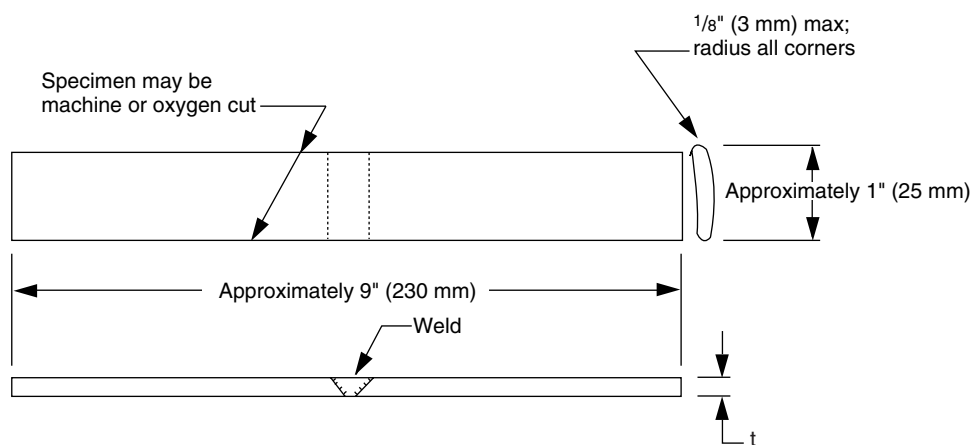
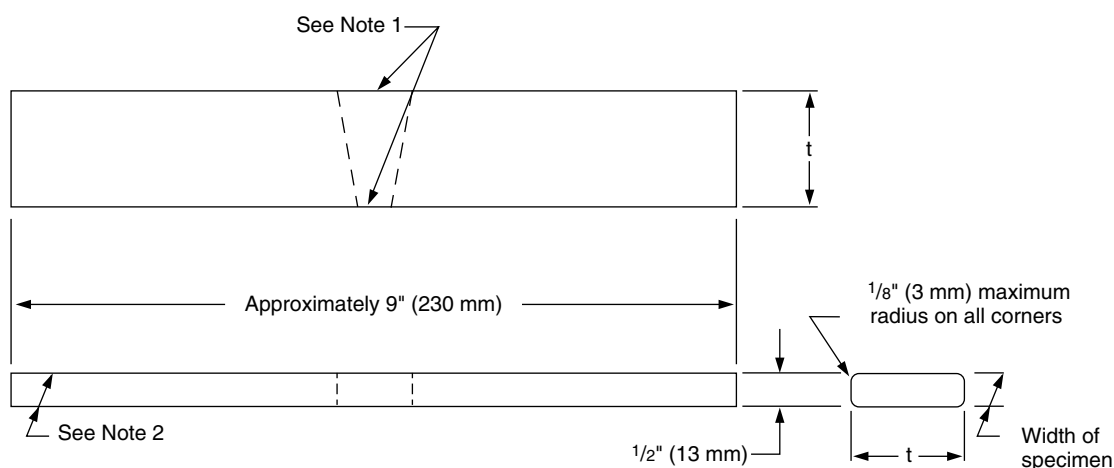

Figure 5—Nick-break Test Specimen



Note: The weld reinforcement shall be removed from both faces with the surface of the specimen. The specimen shall not be flattened prior to testing.

Figure 6—Root- and Face-bend Test Specimen: Wall Thicknesses Less Than or Equal to 0.500 in. (12.7 mm)



Note:

1. The weld reinforcement shall be removed from both faces flush with the surface of the specimen.
2. Specimens may be machine cut to a width of $1/2$ in. (13 mm), or they may be oxygen cut to a width of approximately $3/4$ in. (19 mm) and then machined or ground smooth to a width of $1/2$ in. (13 mm). Cut surfaces shall be smooth and parallel.

Figure 7—Side-bend Test Specimen: Wall Thicknesses Greater than 0.500 in. (12.7 mm)

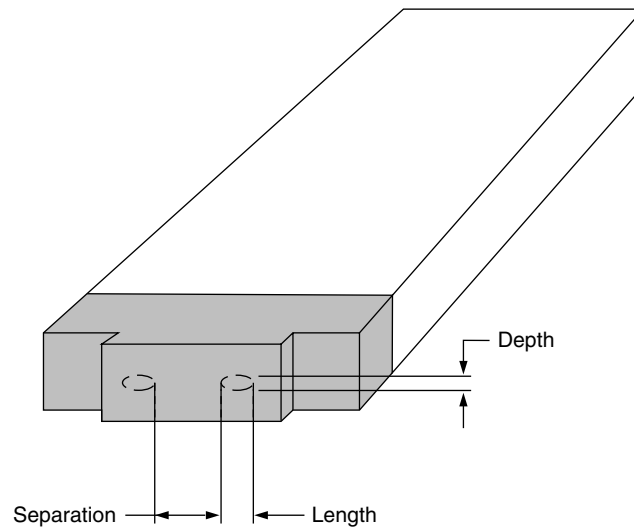

Note: A broken nick-break test specimen is shown; however, this method of dimensioning applies also to broken tensile and fillet weld test specimens.

Figure 8—Dimensioning of Imperfections in Exposed Weld Surfaces

the essential variables described below. If any of the following essential variables are changed, the welder using the new procedure shall be requalified:

- a. A change from one welding process to another welding process or combination of processes, as follows:
 1. A change from one welding process to a different welding process; or
 2. A change in the combination of welding processes, unless the welder has qualified on separate qualification tests, using each of the welding processes that are to be used for the combination of welding processes.
- b. A change in the direction of welding from vertical uphill to vertical downhill or vice versa.
- c. A change of filler-metal classification from Group 1 or 2 to Group 3, or from Group 3 to Group 1 or 2 (see Table 1).
- d. A change from one outside diameter group to another. These groups are defined as follows:
 1. Outside diameter less than 2.375 in. (60.3 mm).
 2. Outside diameter from 2.375 in. (60.3 mm) through 12.750 in. (323.9 mm).
 3. Outside diameter greater than 12.750 in. (323.9 mm).
- e. A change from one wall thickness group to another. These groups are defined as follows:
 1. Nominal pipe wall thickness less than 0.188 in. (4.8 mm).
 2. Nominal pipe wall thickness from 0.188 in. (4.8 mm) through 0.750 in. (19.1 mm).
 3. Nominal pipe wall thickness greater than 0.750 in. (19.1 mm).
- f. A change in position from that for which the welder has already qualified (for example, a change from rolled to fixed

or a change from vertical to horizontal or vice versa). A welder who successfully passes a butt-weld qualification test in the fixed position with the axis inclined 45° from the horizontal plane shall be qualified to do butt welds and lap fillet welds in all positions.

- g. A change in the joint design (for example, the elimination of a backing strip or a change from V bevel to U bevel).

6.3 MULTIPLE QUALIFICATION

6.3.1 General

For multiple qualification, a welder shall successfully complete the two tests described below, using qualified procedures.

For the first test, the welder shall make a butt weld in the fixed position with the axis of the pipe either in the horizontal plane or inclined from the horizontal plane at an angle of not more than 45°. This butt weld shall be made on pipe with an outside diameter of at least 6.625 in. (168.3 mm) and with a wall thickness of at least 0.250 in. (6.4 mm) without a backing strip. The weld shall be acceptable if it meets the requirements of 6.4 and either 6.5 or 6.6. Specimens may be removed from the test weld at the locations shown in Figure 12, or they may be selected at the relative locations shown in Figure 12 but without reference to the top of the pipe, or they may be selected from locations that are spaced equidistantly around the entire pipe circumference. The sequence of adjacent specimen types shall be identical to that shown in Figure 12 for the various pipe diameters.

For the second test, the welder shall lay out, cut, fit, and weld a full-sized branch-on-pipe connection. This test shall

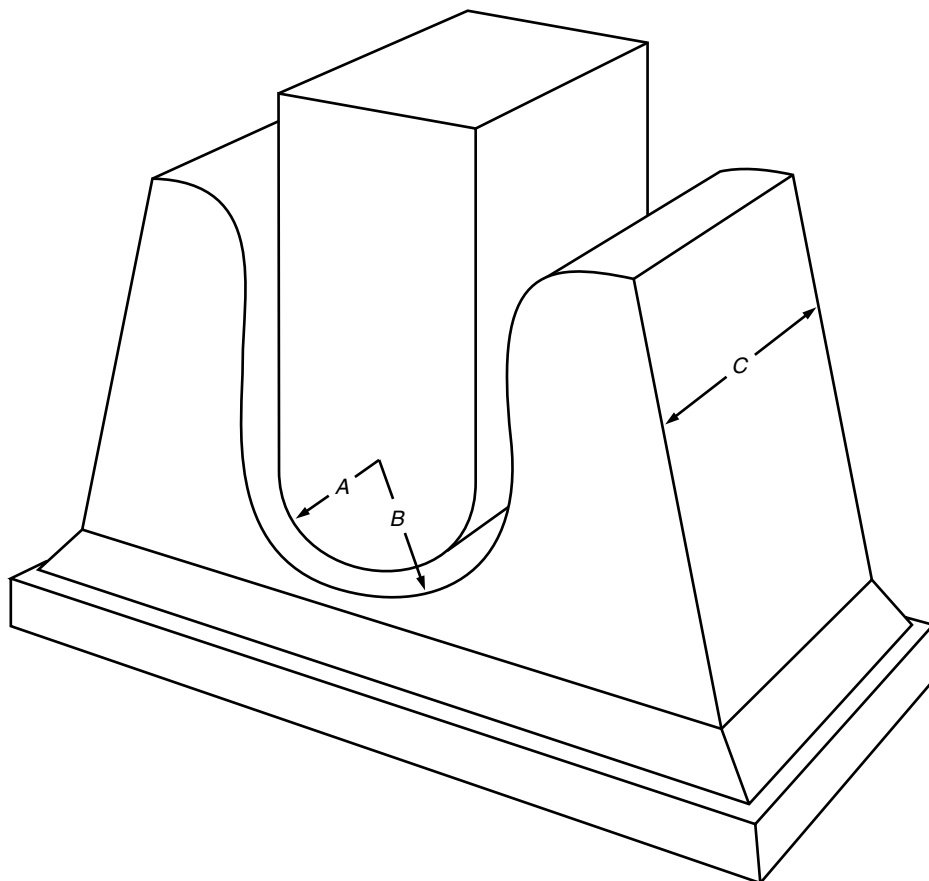

Note: This figure is not drawn to scale. Radius of plunger, $A = 1\frac{3}{4}$ in. (45 mm); radius of die, $B = 2\frac{5}{16}$ in. (60 mm); width of die, $C = 2$ in. (50 mm).

Figure 9—Jig for Guided-bend Tests

be performed with a pipe diameter of at least 6.625 in. (168.3 mm) and with a nominal wall thickness of at least 0.250 in. (6.4 mm). A full-size hole shall be cut in the run. The weld shall be made with the run-pipe axis in the horizontal position and the branch-pipe axis extending vertically downward from the run. The finished weld shall exhibit a neat, uniform workman-like appearance.

The weld shall exhibit complete penetration around the entire circumference. Completed root beads shall not contain any burn-through of more than $\frac{1}{4}$ in. (6 mm). The sum of the maximum dimensions of separate unrepaired burn-throughs in any continuous 12 in. (300 mm) length of weld shall not exceed $\frac{1}{2}$ in. (13 mm).

Four nick-break specimens shall be removed from the weld at the locations shown in Figure 10. They shall be prepared and tested in accordance with 5.8.1 and 5.8.2. The exposed surfaces shall meet the requirements of 5.8.3.

6.3.2 Scope

A welder who has successfully completed the butt-weld qualification test described in 6.3.1 on pipe with an outside diameter greater than or equal to 12.750 in. (323.9 mm) and a full-size branch-connection weld on pipe with an outside diameter greater than or equal to 12.750 in. (323.9 mm) shall be qualified to weld in all positions; on all wall thicknesses, joint designs, and fittings; and on all pipe diameters. A welder who has successfully completed the butt-weld and branch connection requirements of 6.3.1 on pipe with an outside diameter less than 12.750 in. (323.9 mm) shall be qualified to weld in all positions; on all wall thicknesses, joint designs, and fittings; and on all pipe outside diameters less than or equal to the outside diameter used by the welder in the qualification tests.

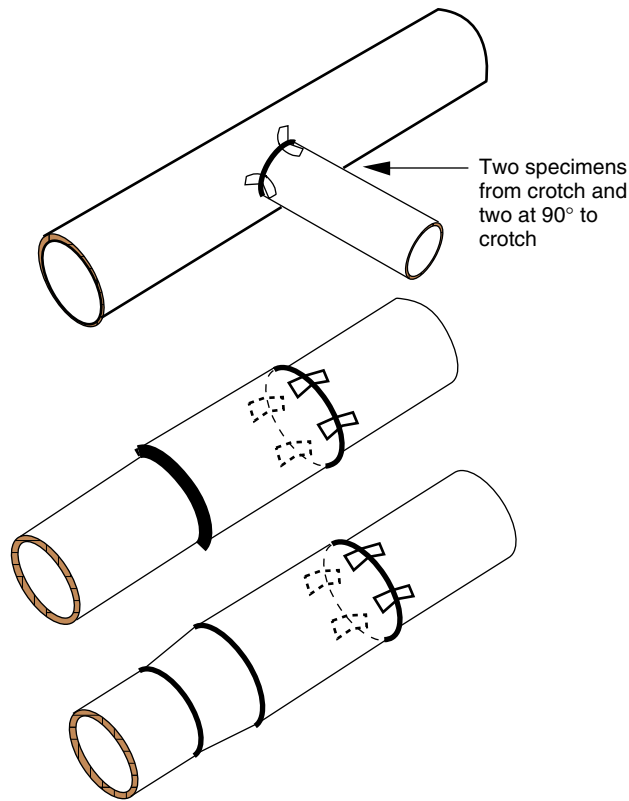

Note: This figure shows the location of test specimens for joints with an outside diameter greater than or equal to 2.375 in. (60.3 mm). For joints with an outside diameter less than 2.375 in. (60.3 mm), specimens shall be cut from the same general location, but two specimens shall be removed from each of two test welds.

Figure 10—Location of Nick-break Test Specimens: Fillet-weld Procedure and Welder Qualification Test Welds

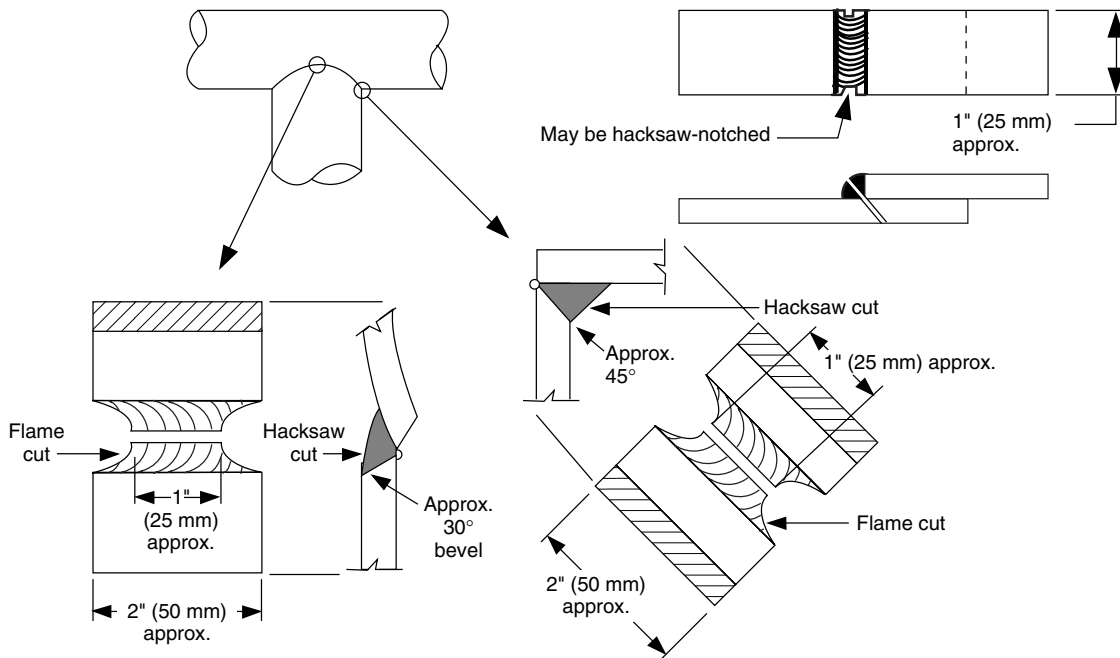

Figure 11—Location of Nick-break Test Specimens: Fillet-weld Procedure and Welder Qualification Test Welds, Including Size-to-size Branch-connection Welder Qualification Test

If any of the following essential variables are changed in a procedure specification, the welder using the new procedure shall be requalified:

- a. A change from one welding process to another welding process or combination of processes, as follows:
 1. A change from one welding process to a different welding process; or
 2. A change in the combination of welding processes, unless the welder has qualified on separate qualification tests, each using the same welding process that is used for the combination of welding processes.
- b. A change in the direction of welding from vertical uphill to vertical downhill, or vice versa.
- c. A change of filler-metal classification from Group 1 or 2 to Group 3 or from Group 3 to Group 1 or 2 (see Table 1).

6.4 VISUAL EXAMINATION

For a qualification test weld to meet the requirements for visual examination, the weld shall be free from cracks, inadequate penetration, and burn-through, and must present a neat workman-like appearance. The depth of undercutting adjacent to the final bead on the outside of the pipe shall not be more than $1/32$ in. (0.8 mm) or 12.5% of the pipe wall thickness, whichever is smaller, and there shall not be more than 2 in. (50 mm) of undercutting in any continuous 12 in. (300 mm) length of weld.

When semi-automatic or mechanized welding is used, filler wire protruding into the inside of the pipe shall be kept to a minimum.

Failure to meet the requirements of this subsection shall be adequate cause to eliminate additional testing.

6.5 DESTRUCTIVE TESTING

6.5.1 Sampling of Test Butt Welds

To test butt welds, samples shall be cut from each test weld. Figure 12 shows the locations from which the specimens are to be removed if the test weld is a complete circumferential weld. If the test weld consists of segments of pipe nipples, an approximately equal number of specimens shall be removed from each segment. The total number of specimens and the tests to which each shall be submitted are shown in Table 3. The specimens shall be air cooled to ambient temperature prior to testing. For pipe with an outside diameter less than or equal to 1.315 in. (33.4 mm), one full-pipe section specimen may be substituted for the root-bend and Nick-break specimens. This full-section specimen shall be tested in accordance with 5.6.2.2 and shall meet the requirements of 6.5.3.

6.5.2 Tensile-strength, Nick-break, and Bend-test Procedures for Butt Welds

The specimens shall be prepared for tensile-strength, Nick-break and bend tests, and the tests shall be performed as described in 5.6. However, for the purpose of welder qualification, it is not necessary to calculate the tensile strength of the coupons. The tensile strength test may even be omitted, in which case the specimens designated for the test shall be subjected to the Nick-break test.

6.5.3 Tensile-strength Test Requirements for Butt Welds

For the tensile-strength test, if any of the reduced-section specimens or the full-section specimen breaks in the weld or at the junction of the weld and the parent material and fails to meet the soundness requirements of 5.6.3.3, the welder shall be disqualified.

6.5.4 Nick-break Test Requirements for Butt Welds

For the Nick-break test, if any specimen shows imperfections that exceed those allowed by 5.6.3.3, the welder shall be disqualified.

6.5.5 Bend Test Requirements for Butt Welds

For the bend tests, if any specimen shows imperfections that exceed those allowed by 5.6.4.3 or 5.6.5.3, the welder shall be disqualified. Welds in high-test pipe may not bend to the full U shape. These welds shall be considered acceptable if the specimens that crack are broken apart and their exposed surfaces meet the requirements of 5.6.3.3.

If one of the bend test specimens fails to meet these requirements and, in the company's opinion, the imperfection observed is not representative of the weld, the test specimen may be replaced by an additional specimen cut adjacent to the one that failed. The welder shall be disqualified if the additional specimen also shows imperfections that exceed the specified limits.

6.5.6 Sampling of Test Fillet Welds

To test fillet welds, specimens shall be cut from each test weld. Figure 10 shows the locations from which the specimens are to be removed if the test weld is a complete circumferential weld. If the test weld consists of segments of pipe nipples, an approximately equal number of specimens shall be removed from each segment. The specimens shall be air cooled to ambient temperature prior to testing.

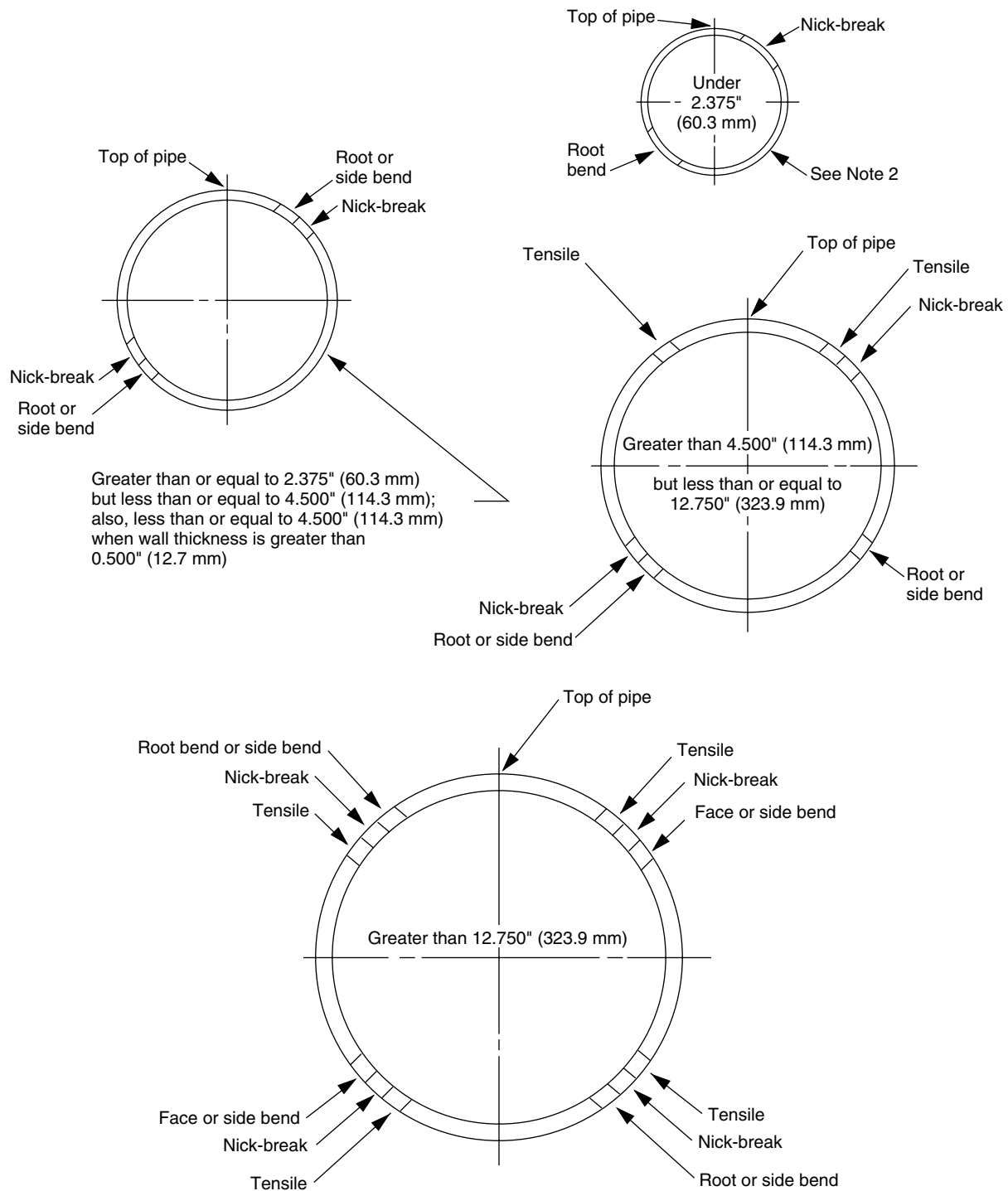

Notes:

1. At the company's option, the locations may be rotated, provided they are equally spaced around the pipe; however, specimens shall not include the longitudinal weld.
2. One full-section tensile-strength specimen may be used for pipe with an outside diameter less than or equal to 1.315 in. (33.4 mm).

Figure 12—Location of Test Butt-weld Specimens for Welder Qualification Test

Table 3—Type and Number of Butt-weld Test Specimens per Welder for Welder Qualification Test and Destructive Testing of Production Welds

Outside Diameter of Pipe		Number of Specimens					
Inches	Millimeters	Tensile Strength	Nick-Break	Root Bend	Face Bend	Side Bend	Total
Wall Thickness ≤ 0.500 in. (12.7 mm)							
< 2.375	< 60.3	0	2	2	0	0	4 ^a
2.375 – 4.500	60.3 – 323.9	0	2	2	0	0	4
> 4.500 – 12.750	> 114.3 – 323.9	2	2	2	0	0	6
> 12.750	> 323.9	4	4	2	2	0	12
Wall Thickness > 0.500 in. (12.7 mm)							
≤ 4.500	≤ 114.3	0	2	0	0	2	4
> 4.500 – 12.750	> 114.3 – 323.9	2	2	0	0	2	6
> 12.750	> 323.9	4	4	0	0	4	12

^aFor pipe less than or equal to 1.315 in. (33.4 mm) in outside diameter, specimens from two welds or one full-section tensile-strength specimen shall be taken.

6.5.7 Test Method and Requirements for Fillet Welds

The fillet-weld specimens shall be prepared and the test shall be performed as described in 5.8.

6.6 RADIOGRAPHY-BUTT WELDS ONLY

6.6.1 General

At the company's option, the qualification butt weld may be examined by radiography in lieu of the tests specified in 6.5.

6.6.2 Inspection Requirements

Radiographs shall be made of each of the test welds. The welder shall be disqualified if any of the test welds do not meet the requirements of 9.3.

Radiographic inspection shall not be used for the purpose of locating sound areas or areas that contain imperfections and subsequently making tests of such areas to qualify or disqualify a welder.

6.7 RETESTING

If, in the mutual opinion of the company and the contractor's representatives, a welder fails to pass the qualification test because of unavoidable conditions or conditions beyond his control, the welder may be given a second opportunity to qualify. No further retests shall be given until the welder has submitted proof of subsequent welder training that is acceptable to the company.

6.8 RECORDS

A record shall be maintained of the tests given to each welder and of the detailed results of each test. A form similar to that shown in Figure 2 should be used. (This form should be developed to suit the needs of the individual company but

must be sufficiently detailed to demonstrate that the qualification test met the requirements of this standard.) A list of qualified welders and the procedures for which they are qualified shall be maintained. A welder may be required to requalify if a question arises about his competence.

7 Design and Preparation of a Joint for Production Welding

7.1 GENERAL

Piping shall be welded by qualified welders using qualified procedures. The surfaces to be welded shall be smooth, uniform, and free from laminations, tears, scale, slag, grease, paint, and other deleterious material that might adversely affect the welding. The joint design and spacing between abutting ends shall be in accordance with the procedure specification used.

7.2 ALIGNMENT

The alignment of abutting ends shall minimize the offset between surfaces. For pipe ends of the same nominal thickness, the offset should not exceed $1/8$ in. (3 mm). Larger variations are permissible provided the variation is caused by variations of the pipe end dimensions within the pipe purchase specification tolerances, and such variations have been distributed essentially uniformly around the circumference of the pipe. Hammering of the pipe to obtain proper lineup should be kept to a minimum.

7.3 USE OF LINEUP CLAMP FOR BUTT WELDS

Lineup clamps shall be used for butt welds in accordance with the procedure specification. When it is permissible to remove the lineup clamp before the root bead is completed, the completed part of the bead shall be in approximately equal segments spaced approximately equally around the cir-

circumference of the joint. However, when an internal lineup clamp is used and conditions make it difficult to prevent movement of the pipe or if the weld will be unduly stressed, the root bead shall be completed before clamp tension is released. Root-bead segments used in connection with external clamps should be uniformly spaced around the circumference of the pipe and shall have an aggregate length of at least 50% of the pipe circumference before the clamp is removed.

7.4 BEVEL

7.4.1 Mill Bevel

All mill bevels on pipe ends shall conform to the joint design used in the procedure specification.

7.4.2 Field Bevel

Pipe ends should be field beveled by machine tool or machine oxygen cutting. If authorized by the company, manual oxygen cutting may also be used. The beveled ends shall be reasonably smooth and uniform, and dimensions shall be in accordance with the procedure specification.

7.5 WEATHER CONDITIONS

Welding shall not be done when the quality of the completed weld would be impaired by the prevailing weather conditions, including but not limited to airborne moisture, blowing sands, or high winds. Windshields may be used when practical. The company shall decide if weather conditions are suitable for welding.

7.6 CLEARANCE

When the pipe is welded above ground, the working clearance around the pipe at the weld should not be less than 16 in. (400 mm). When the pipe is welded in a trench, the bell hole shall be large enough to provide the welder or welders with ready access to the joint.

7.7 CLEANING BETWEEN BEADS

Scale and slag shall be removed from each bead and groove. Power tools shall be used when called for in the procedure specification; otherwise, cleaning may be performed with either hand or power tools.

When semiautomatic or mechanized welding is used, surface porosity clusters, bead starts, and high points shall be removed by grinding before weld metal is deposited over them. When requested by the company, heavy glass deposits shall be removed before weld metal is deposited over them.

7.8 POSITION WELDING

7.8.1 Procedure

All position welds shall be made with the parts to be joined secured against movement and with adequate clearance around the joint to allow the welder or welders space in which to work.

7.8.2 Filler and Finish Beads

For position welding, the number of filler and finish beads shall allow the completed weld a substantially uniform cross section around the entire circumference of the pipe. At no point shall the crown surface fall below the outside surface of the pipe, nor should it be raised above the parent metal by more than $1/16$ in. (1.6 mm).

Two beads shall not be started at the same location. The face of the completed weld should be approximately $1/8$ in. (3 mm) wider than the width of the original groove. The completed weld shall be thoroughly brushed and cleaned.

7.9 ROLL WELDING

7.9.1 Alignment

At the company's option, roll welding shall be permitted, provided alignment is maintained by the use of skids or a structural framework with an adequate number of roller dollies to prevent sag in the supported lengths of pipe.

7.9.2 Filler and Finish Beads

For roll welding, the number of filler and finish beads shall be such that the completed weld has a substantially uniform cross section around the entire circumference of the pipe. At no point shall the crown surface fall below the outside surface of the pipe, nor should it be raised above the parent metal by more than $1/16$ in. (1.6 mm).

The face of the completed weld should be approximately $1/8$ in. (3 mm) wider than the width of the original groove. As the welding progresses, the pipe shall be rolled to maintain welding at or near the top of the pipe. The completed weld shall be thoroughly brushed and cleaned.

7.10 IDENTIFICATION OF WELDS

Each welder shall identify his work in the manner prescribed by the company.

7.11 PRE- AND POST-HEAT TREATMENT

The procedure specification shall specify the pre- and post-heat treatment practices to be followed when materials or weather conditions make either or both treatments necessary.

8 Inspection and Testing of Production Welds

8.1 RIGHTS OF INSPECTION

The company shall have the right to inspect all welds by nondestructive means or by removing welds and subjecting them to mechanical tests. The inspection may be made during the welding or after the weld has been completed. The frequency of inspection shall be as specified by the company.

8.2 METHODS OF INSPECTION

Nondestructive testing may consist of radiographic inspection or another method specified by the company. The method used shall produce indications of imperfections that can be accurately interpreted and evaluated. The welds shall be evaluated on the basis of either Section 9 or, at the company's option, Appendix A. In the latter case, more extensive inspection to determine the imperfection size is required.

Destructive testing shall consist of the removal of completed welds, sectioning of the welds into specimens, and the examination of the specimens. The specimens shall be prepared in accordance with and shall meet the requirements of 6.5. The company shall have the right to accept or reject any weld that does not meet the requirements for the method by which it was inspected. The welder who makes a weld that fails to comply with the requirements may be disqualified from further work.

Operators of nondestructive inspection equipment may be required to demonstrate the inspection procedure's capability to detect defects and the operator's ability to properly interpret the indications given by the equipment.

Trepanning methods of testing shall not be used.

8.3 QUALIFICATION OF INSPECTION PERSONNEL

Welding inspection personnel shall be qualified by experience and training for the specified inspection task they perform. Their qualifications shall be acceptable to the company.

Documentation of these qualifications shall be retained by the company and shall include but is not limited to the following:

- a. Education and experience.
- b. Training.
- c. Results of any qualification examinations.

8.4 CERTIFICATION OF NONDESTRUCTIVE TESTING PERSONNEL

8.4.1 Procedures

Nondestructive testing personnel shall be certified to Level I, II or III in accordance with the recommendations of American Society for Nondestructive Testing, Recommended Prac-

tice No. SNT-TC-1A, ACCP or any other recognized national certification program that shall be acceptable to the company for the test method used. Only Level II or III personnel shall interpret test results.

8.4.2 Record

A record of certified nondestructive testing personnel shall be maintained by the company. The record shall include the results of certification tests, the agency and person granting certification, and the date of certification. Nondestructive testing personnel may be required to be recertified at the company's option or if any question arises about their ability. Levels I and II nondestructive testing personnel shall be recertified at least every 3 years. Level III nondestructive testing personnel shall be recertified at least every 5 years.

9 Acceptance Standards for Nondestructive Testing

9.1 GENERAL

The acceptance standards presented in this section apply to imperfections located by radiographic, magnetic particle, liquid penetrant, and ultrasonic test methods. They may also be applied to visual inspection. Nondestructive testing shall not be used to select welds that are subjected to destructive testing in accordance with 6.5.

9.2 RIGHTS OF REJECTION

All nondestructive test methods are limited in the information that can be derived from the indications they produce. The company may therefore reject any weld that appears to meet these acceptance standards if, in its opinion, the depth of an imperfection may be detrimental to the weld.

9.3 RADIOGRAPHIC TESTING

Note: All densities referred to in 9.3.1 through 9.3.13 are based on negative images.

9.3.1 Inadequate Penetration without High-low

Inadequate penetration without high-low (IP) is defined as the incomplete filling of the weld root. This condition is shown schematically in Figure 13. IP shall be considered a defect should any of the following conditions exist:

- a. The length of an individual indication of IP exceeds 1 in. (25 mm).
- b. The aggregate length of indications of IP in any continuous 12 in. (300 mm) length of weld exceeds 1 in. (25 mm).
- c. The aggregate length of indications of IP exceeds 8% of the weld length in any weld less than 12 in. (300 mm) in length.

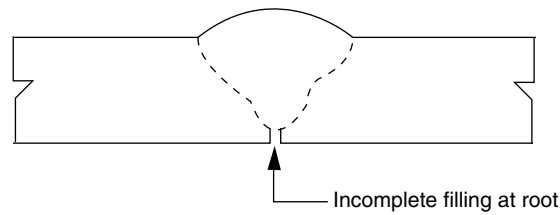

Note: One or both root faces may be inadequately filled at the inside surface.

Figure 13—Inadequate Penetration without High-low (IP)

9.3.2 Inadequate Penetration Due to High-low

Inadequate penetration due to high-low (IPD) is defined as the condition that exists when one edge of the root is exposed (or unbonded) because adjacent pipe or fitting joints are misaligned. This condition is shown schematically in Figure 14. IPD shall be considered a defect should any of the following conditions exist:

- The length of an individual indication of IPD exceeds 2 in. (50 mm).
- The aggregate length of indications of IPD in any continuous 12 in. (300 mm) length of weld exceeds 3 in. (75 mm).

9.3.3 Inadequate Cross Penetration

Inadequate cross penetration (ICP) is defined as a subsurface imperfection between the first inside pass and the first outside pass that is caused by inadequately penetrating the vertical land faces. This condition is shown schematically in Figure 15. ICP shall be considered a defect should any of the following conditions exist:

- The length of an individual indication of ICP exceeds 2 in. (50 mm).
- The aggregate length of indications of ICP in any continuous 12 in. (300 mm) length of weld exceeds 2 in. (50 mm).

9.3.4 Incomplete Fusion

Incomplete fusion (IF) is defined as a surface imperfection between the weld metal and the base material that is open to the surface. This condition is shown schematically in Figure 16. IF shall be considered a defect should any of the following conditions exist:

- The length of an individual indication of IF exceeds 1 in. (25 mm).
- The aggregate length of indications of IF in any continuous 12 in. (300 mm) length of weld exceeds 1 in. (25 mm).
- The aggregate length of indications of IF exceeds 8% of the weld length in any weld less than 12 in. (300 mm) in length.

9.3.5 Incomplete Fusion Due to Cold Lap

Incomplete fusion due to cold lap (IFD) is defined as an imperfection between two adjacent weld beads or between the weld metal and the base metal that is not open to the surface. This condition is shown schematically in Figure 17. IFD shall be considered a defect should any of the following conditions exist:

- The length of an individual indication of IFD exceeds 2 in. (50 mm).
- The aggregate length of indications of IFD in any continuous 12 in. (300 mm) length of weld exceeds 2 in. (50 mm).
- The aggregate length of indications of IFD exceeds 8% of the weld length.

9.3.6 Internal Concavity

Internal concavity (IC) is defined in 3.2.8 and is shown schematically in Figure 18. Any length of internal concavity is acceptable, provided the density of the radiographic image of the internal concavity does not exceed that of the thinnest adjacent parent material. For areas that exceed the density of the thinnest adjacent parent material, the criteria for burn-through (see 9.3.7) are applicable.

9.3.7 Burn-through

9.3.7.1 A burn-through (BT) is defined as a portion of the root bead where excessive penetration has caused the weld puddle to be blown into the pipe.

9.3.7.2 For pipe with an outside diameter greater than or equal to 2.375 in. (60.3 mm), a BT shall be considered a defect should any of the following conditions exist:

- The maximum dimension exceeds $\frac{1}{4}$ in. (6 mm) and the density in any portion of the BTs image exceeds that of the thinnest adjacent parent material.
- The maximum dimension exceeds the thinner of the nominal wall thicknesses joined, and the density in any portion of the BTs image exceeds that of the thinnest adjacent parent material.
- The sum of the maximum dimensions of separate BTs whose image density for any portion of the BTs exceeds that

of the thinnest adjacent parent material and exceeds $\frac{1}{2}$ in. (13 mm) in any continuous 12 in. (300 mm) length of weld or the total weld length, whichever is less.

9.3.7.3 For pipe with an outside diameter less than 2.375 in. (60.3 mm), a BT shall be considered a defect when any of the following conditions exists:

- The maximum dimension exceeds $\frac{1}{4}$ in. (6 mm) and the density in any portion of the BTs image exceeds that of the thinnest adjacent parent material.
- The maximum dimension exceeds the thinner of the nominal wall thicknesses joined, and the density in any portion of the BT's image exceeds that of the thinnest adjacent parent material.
- More than one BT of any size is present and the density in any portion of the BTs image exceeds that of the thinnest adjacent parent material.

9.3.8 Slag Inclusions

9.3.8.1 A slag inclusion is defined as a nonmetallic solid entrapped in the weld metal or between the weld metal and the parent material. Elongated slag inclusions (ESIs)—e.g., continuous or broken slag lines or wagon tracks—are usually found at the fusion zone. Isolated slag inclusions (ISIs) are irregularly shaped and may be located anywhere in the weld. For evaluation purposes, when the size of a radiographic indication of slag is measured, the indication's maximum dimension shall be considered its length.

9.3.8.2 For pipe with an outside diameter greater than or equal to 2.375 in. (60.3 mm), slag inclusions shall be considered a defect should any of the following conditions exist:

- The length of an ESI indication exceeds 2 in. (50 mm).

Note: Parallel ESI indications separated by approximately the width of the root bead (wagon tracks) shall be considered a single indication unless the width of either of them exceeds $\frac{1}{32}$ in. (0.8 mm). In that event, they shall be considered separate indications.

- The aggregate length of ESI indications in any continuous 12 in. (300 mm) length of weld exceeds 2 in. (50 mm).
- The width of an ESI indication exceeds $\frac{1}{16}$ in. (1.6 mm).
- The aggregate length of ISI indications in any continuous 12 in. (300 mm) length of weld exceeds $\frac{1}{2}$ in. (13 mm).
- The width of an ISI indication exceeds $\frac{1}{8}$ in. (3 mm).
- More than four ISI indications with the maximum width of $\frac{1}{8}$ in. (3 mm) are present in any continuous 12 in. (300 mm) length of weld.
- The aggregate length of ESI and ISI indications exceeds 8% of the weld length.

9.3.8.3 For pipe with an outside diameter less than 2.375 in. (60.3 mm), slag inclusions shall be considered a defect should any of the following conditions exist:

- The length of an ESI indication exceeds three times the thinner of the nominal wall thicknesses joined.

Note: Parallel ESI indications separated by approximately the width of the root bead (wagon tracks) shall be considered a single indication unless the width of either of them exceeds $\frac{1}{32}$ in. (0.8 mm). In that event, they shall be considered separate indications.

- The width of an ESI indication exceeds $\frac{1}{16}$ in. (1.6 mm).
- The aggregate length of ISI indications exceeds two times the thinner of the nominal wall thicknesses joined and the width exceeds one-half the thinner of the nominal wall thicknesses joined.
- The aggregate length of ESI and ISI indications exceeds 8% of the weld length.

9.3.9 Porosity

9.3.9.1 Porosity is defined as gas trapped by solidifying weld metal before the gas has a chance to rise to the surface of the molten puddle and escape. Porosity is generally spherical but may be elongated or irregular in shape, such as piping (wormhole) porosity. When the size of the radiographic indication produced by a pore is measured, the maximum dimension of the indication shall apply to the criteria given in 9.3.9.2 through 9.3.9.4.

9.3.9.2 Individual or scattered porosity (P) shall be considered a defect should any of the following conditions exist:

- The size of an individual pore exceeds $\frac{1}{8}$ in. (3 mm).
- The size of an individual pore exceeds 25% of the thinner of the nominal wall thicknesses joined.
- The distribution of scattered porosity exceeds the concentration permitted by Figures 19 or 20.

9.3.9.3 Cluster porosity (CP) that occurs in any pass except the finish pass shall comply with the criteria of 9.3.9.2. CP that occurs in the finish pass shall be considered a defect should any of the following conditions exist.

- The diameter of the cluster exceeds $\frac{1}{2}$ in. (13 mm).
- The aggregate length of CP in any continuous 12 in. (300 mm) length of weld exceeds $\frac{1}{2}$ in. (13 mm).

9.3.9.4 Hollow-bead porosity (HB) is defined as elongated linear porosity that occurs in the root pass. HB shall be considered a defect should any of the following conditions exist:

- The length of an individual indication of HB exceeds $\frac{1}{2}$ in. (13 mm).
- The aggregate length of indications of HB in any continuous 12 in. (300 mm) length of weld exceeds 2 in. (50 mm).
- Individual indications of HB, each greater than $\frac{1}{4}$ in. (6 mm) in length, are separated by less than 2 in. (50 mm).
- The aggregate length of all indications of HB exceeds 8% of the weld length.

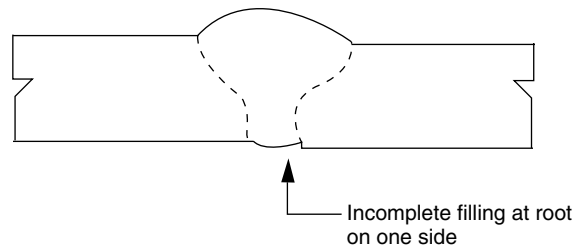

Figure 14—Inadequate Penetration Due to High-low (IPD)

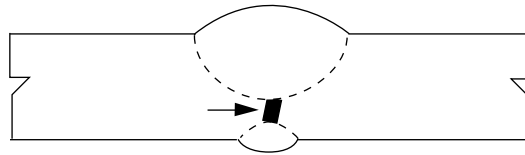

Figure 15—Inadequate Cross Penetration (ICP)

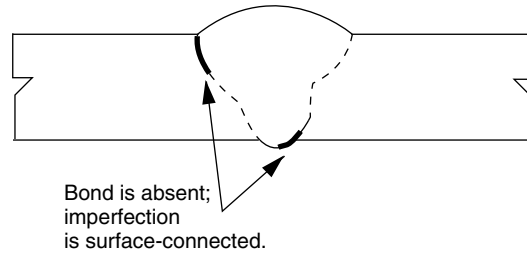
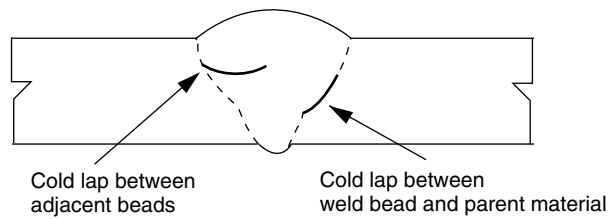

Figure 16—Incomplete Fusion at Root of Bead or Top of Joint (IF)



Note: The cold lap shown is not surface-connected.

Figure 17—Incomplete Fusion Due to Cold Lap (IFD)

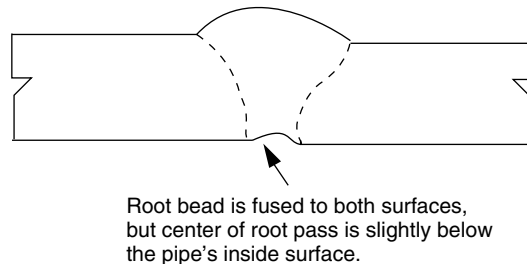

Figure 18—Internal Concavity (IC)

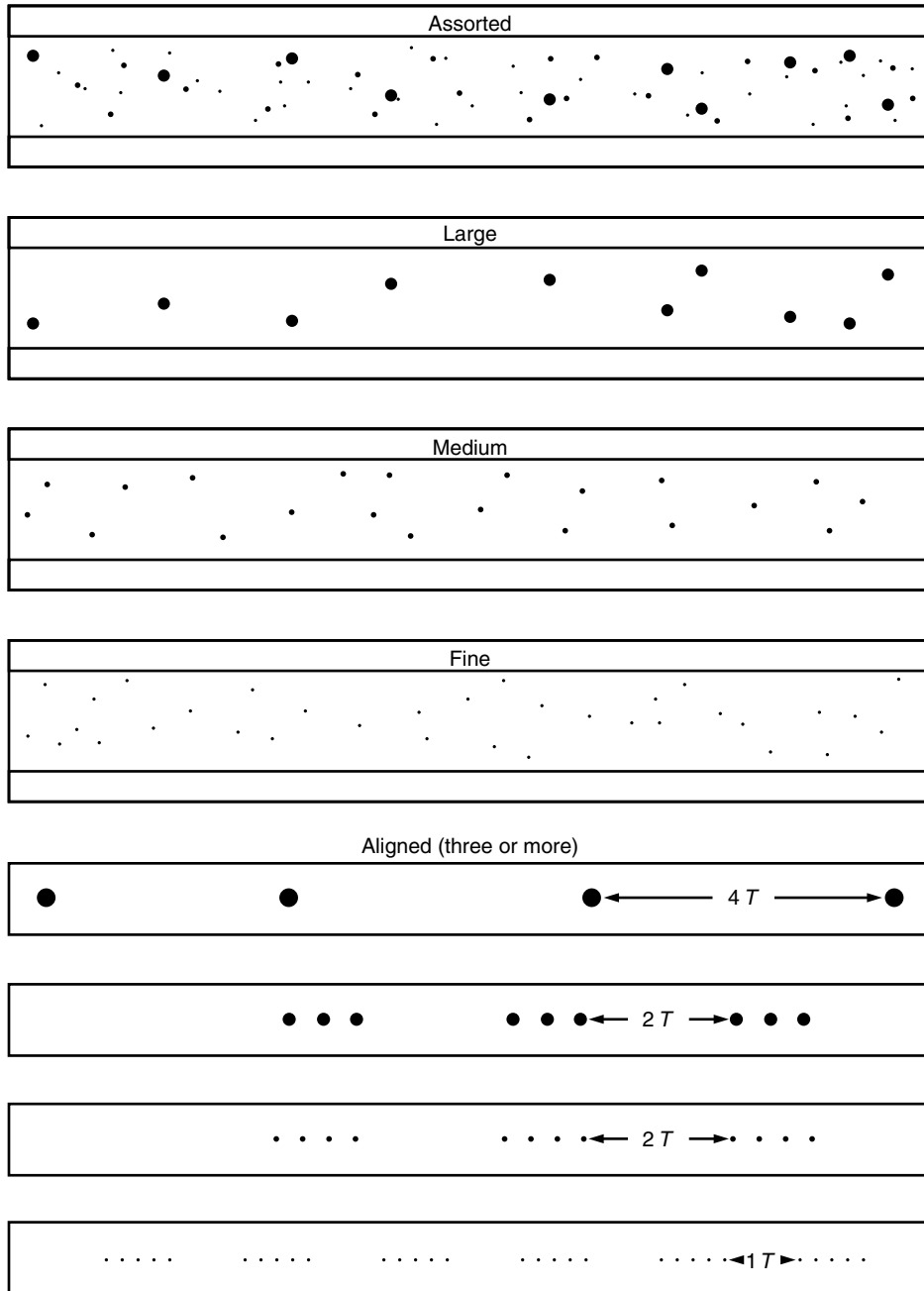

Figure 19—Maximum Distribution of Gas Pockets: Wall Thicknesses Less Than or Equal to 0.500 in. (12.7 mm)

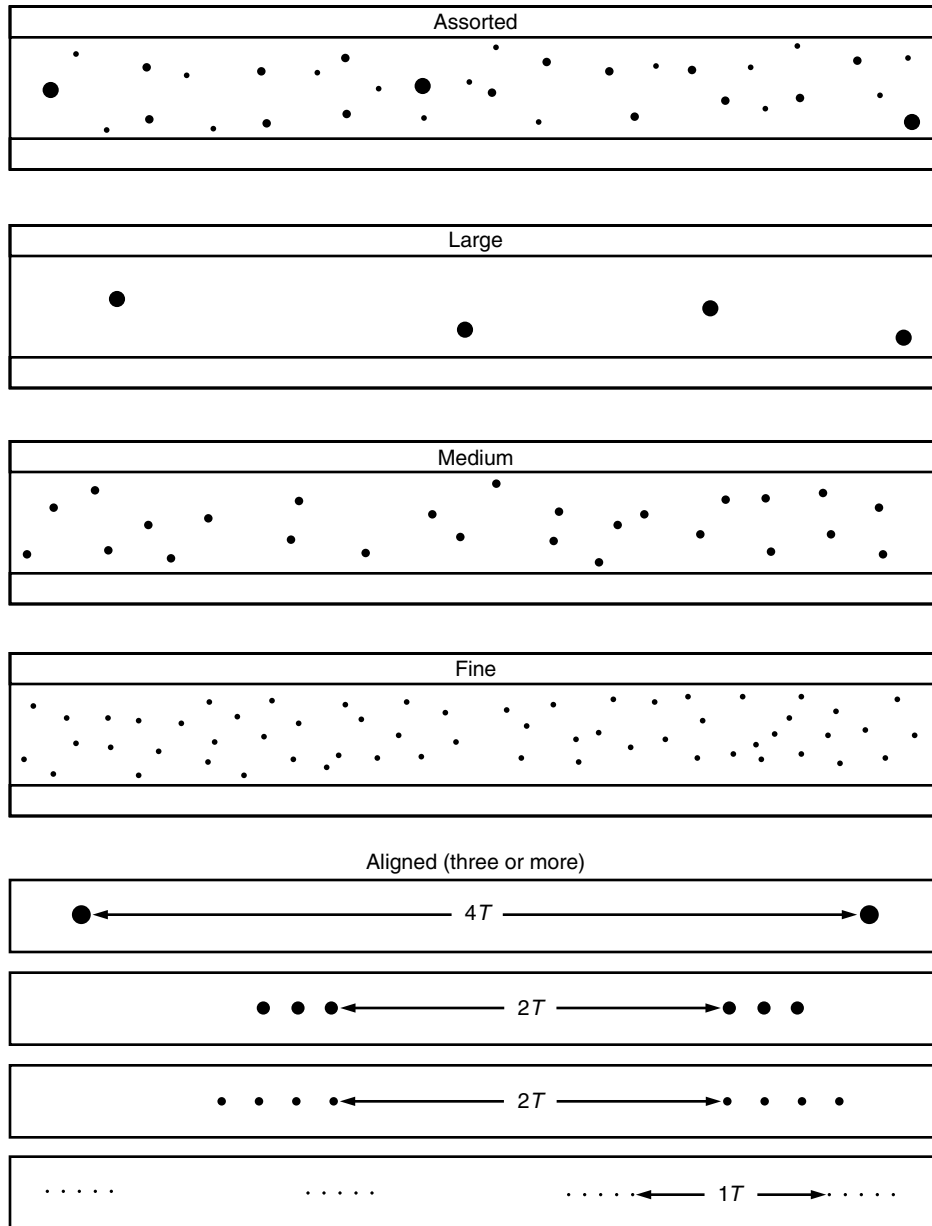

Figure 20—Maximum Distribution of Gas Pockets: Wall Thicknesses Greater Than 0.500 in. (12.7 mm)

9.3.10 Cracks

Cracks (C) shall be considered a defect should any of the following conditions exist:

- a. The crack, of any size or location in the weld, is not a shallow crater crack or star crack.
- b. The crack is a shallow crater crack or star crack with a length that exceeds $5/32$ in. (4 mm).

Note: Shallow crater cracks or star cracks are located at the stopping point of weld beads and are the result of weld metal contractions during solidification.

9.3.11 Undercutting

Undercutting is defined as a groove melted into the parent material adjacent to the toe or root of the weld and left unfilled by weld metal. Undercutting adjacent to the cover pass (EU) or root pass (IU) shall be considered a defect should any of the following conditions exist:

- a. The aggregate length of indications of EU and IU, in any combination, in any continuous 12 in. (300 mm) length of weld exceeds 2 in. (50 mm).
- b. The aggregate length of indications of EU and IU, in any combination, exceeds one-sixth of the weld length.

Note: See 9.7 for acceptance standards for undercutting when visual and mechanical measurements are employed.

9.3.12 Accumulation of Imperfections

Excluding incomplete penetration due to high-low and undercutting, any accumulation of imperfections (AI) shall be considered a defect should any of the following conditions exist:

- a. The aggregate length of indications in any continuous 12 in. (300 mm) length of weld exceeds 2 in. (50 mm).
- b. The aggregate length of indications exceeds 8% of the weld length.

9.3.13 Pipe or Fitting Imperfections

Imperfections in the pipe or fittings detected by radiographic testing shall be reported to the company. Their disposition shall be as directed by the company.

9.4 MAGNETIC PARTICLE TESTING

9.4.1 Classification of Indications

9.4.1.1 Indications produced by magnetic particle testing are not necessarily imperfections. Magnetic and metallurgical variations may produce indications that are similar to those produced by imperfections but that are not relevant to acceptability. The criteria given in 9.4.1.2 and 9.4.1.3 apply when indications are evaluated.

9.4.1.2 Any indication with a maximum dimension of $1/16$ in. (1.6 mm) or less shall be classified as nonrelevant. Any larger indication believed to be nonrelevant shall be regarded as relevant until re-examined by magnetic particle or another non-destructive testing method to determine whether or not an actual imperfection exists. The surface may be ground or otherwise conditioned before re-examination. After an indication is determined to be nonrelevant, other nonrelevant indications of the same type need not be re-examined.

9.4.1.3 Relevant indications are those caused by imperfections. Linear indications are those in which the length is more than three times the width. Rounded indications are those in which the length is three times the width or less.

9.4.2 Acceptance Standards

Relevant indications shall be considered defects should any of the following conditions exist:

- a. Linear indications evaluated as crater cracks or star cracks exceed $5/32$ in. (4 mm) in length.
- b. Linear indications are evaluated as cracks other than crater cracks or star cracks.
- c. Linear indications are evaluated as IF and exceed 1 in. (25 mm) in total length in a continuous 12 in. (300 mm) length of weld or 8% of the weld length.

Rounded indications shall be evaluated according to the criteria of 9.3.9.2 and 9.3.9.3, as applicable. For evaluation purposes, the maximum dimension of a rounded indication shall be considered its size.

Note: When doubt exists about the type of imperfection being disclosed by an indication, verification may be obtained by using other nondestructive testing methods.

9.4.3 Pipe or Fitting Imperfections

Imperfections in the pipe or fittings detected by magnetic particle testing shall be reported to the company. Their disposition shall be as directed by the company.

9.5 LIQUID PENETRANT TESTING

9.5.1 Classification of Indications

9.5.1.1 Indications produced by liquid penetrant testing are not necessarily imperfections. Machining marks, scratches, and surface conditions may produce indications that are similar to those produced by imperfections but that are not relevant to acceptability. The criteria given in 9.5.1.2 and 9.5.1.3 apply when indications are evaluated.

9.5.1.2 Any indication with a maximum dimension of $1/16$ in. (2 mm) or less shall be classified as nonrelevant. Any larger indication believed to be nonrelevant shall be regarded as relevant until re-examined by liquid penetrant or another non-destructive testing method to determine whether or not an actual

imperfection exists. The surface may be ground or otherwise conditioned before re-examination. After an indication is determined to be nonrelevant, other nonrelevant indications of the same type need not be re-examined.

9.5.1.3 Relevant indications are those caused by imperfections. Linear indications are those in which the length is more than three times the width. Rounded indications are those in which the length is three times the width or less.

9.5.2 Acceptance Standards

Relevant indications shall be considered defects should any of the following conditions exist:

- a. Linear indications are evaluated as crater cracks or star cracks and exceed $5/32$ in. (4 mm) in length.
- b. Linear indications are evaluated as cracks other than crater cracks or star cracks.
- c. Linear indications are evaluated as IF and exceed 1 in. (25 mm) in total length in a continuous 12 in. (300 mm) length of weld or 8% of the weld length.

Rounded indications shall be evaluated according to the criteria of 9.3.9.2 and 9.3.9.3, as applicable. For evaluation purposes, the maximum dimension of a rounded indication shall be considered its size.

Note: When doubt exists about the type of imperfection being disclosed by an indication, verification may be obtained by using other nondestructive testing methods.

9.5.3 Pipe or Fitting Imperfections

Imperfections in the pipe or fittings detected by liquid penetrant testing shall be reported to the company. Their disposition shall be as directed by the company.

9.6 ULTRASONIC TESTING

9.6.1 Classification of Indications

9.6.1.1 Indications produced by ultrasonic testing are not necessarily defects. Changes in the weld geometry due to alignment offset of abutting pipe ends, changes in weld reinforcement profile of I.D. root and O.D. capping passes, internal chamfering, and ultrasonic wave mode conversion due to such conditions may cause geometric indications that are similar to those caused by weld imperfections but that are not relevant to acceptability.

9.6.1.2 Linear indications are defined as indications with their greatest dimension in the weld length direction. Typical linear indications may be caused by, but are not limited to, the following types of imperfections: inadequate penetration without high-low (IP), inadequate penetration due to high-

low (IPD), inadequate cross penetration (ICP), incomplete fusion (IF), incomplete fusion due to cold lap (IFD), elongated slag inclusion (ESI), cracks (C), undercutting adjacent to the cover pass (EU) or root pass (IU), and hollow bead porosity (HB).

9.6.1.3 Transverse indications are defined as indications with their greatest dimension across the weld. Typical transverse indications may be caused by, but are not limited, to the following types of imperfections: cracks (C), isolated slag inclusions (ISI), and incomplete fusion due to cold lap (IFD) at start/stops in the weld passes.

9.6.1.4 Volumetric indications are defined as three-dimensional indications. Such indications may be caused by single or multiple inclusions, voids, or pores. Partially-filled voids, pores, or small inclusions at start/stops in weld passes may cause larger indications in the transverse direction than in the weld length direction. Typical volumetric indications may be caused by, but are not limited to, the following types of imperfections: internal concavity (IC), burn-through (BT), isolated slag inclusions (ISI), porosity (P), and cluster porosity (CP).

9.6.1.5 Relevant indications are those caused by imperfections. Relevant indications shall be evaluated at the evaluation level given in 11.4.7 to the acceptance standards given in 9.6.2.

Note: When doubt exists about the type of imperfection being disclosed by an indication, verification may be obtained by using other nondestructive testing methods.

9.6.2 Acceptance Standards

9.6.2.1 Indications shall be considered defects should any of the following conditions exist:

- a. Indications determined to be cracks (C).
- b. Individual indications with a vertical height (through-wall) dimension determined to be greater than one quarter of the wall thickness.
- c. Multiple indications at the same circumferential location with a summed vertical height (through-wall) dimension exceeding one half the wall thickness.

9.6.2.2 Linear surface (LS) indications (other than cracks) interpreted to be open to the I.D. or O.D. surface shall be considered defects should any of the following conditions exist:

- a. The aggregate length of LS indications in any continuous 12 in. (300 mm) length of weld exceeds 1 in. (25 mm).
- b. The aggregate length of LS Indications exceeds 8% of the weld length.

9.6.2.3 Linear buried (LB) indications (other than cracks) interpreted to be subsurface within the weld and not I.D. or

O.D. surface-connected shall be considered defects should any of the following conditions exist:

- a. The aggregate length of LB indications in any continuous 12 in. (300 mm) length of weld exceeds 2 in. (50 mm).
- b. The aggregate length of LB indications exceeds 8% of the weld length.

9.6.2.4 Transverse (T) indications (other than cracks) shall be considered volumetric and evaluated using the criteria for volumetric indications. The letter T shall be used to designate all reported transverse indications.

9.6.2.5 Volumetric cluster (VC) indications shall be considered defects when the maximum dimension of VC indications exceeds $\frac{1}{2}$ in. (13 mm).

9.6.2.6 Volumetric individual (VI) indications shall be considered defects when the maximum dimension of VI indications exceeds $\frac{1}{8}$ in. (3 mm).

9.6.2.7 Volumetric root (VR) indications interpreted to be open to the I.D. surface shall be considered defects should any of the following conditions exist:

- a. The maximum dimension of VR indications exceeds $\frac{1}{4}$ in. (6 mm) or the nominal wall thickness, whichever is less.
- b. The total length of VR indications exceeds $\frac{1}{2}$ in. (13 mm) in any continuous 12 in. (300 mm) length.

9.6.2.8 Any accumulation of relevant indications (AR) shall be considered a defect when any of the following conditions exist:

- a. The aggregate length of indications above evaluation level exceeds 2 in. (50 mm) in any 12 in. (300 mm) length of weld.
- b. The aggregate length of indications above evaluation level exceeds 8% of the weld length.

9.6.3 Pipe or Fitting Imperfections

Imperfections in the pipe or fittings detected by ultrasonic testing shall be reported to the company. Their disposition shall be as directed by the company.

9.7 VISUAL ACCEPTANCE STANDARDS FOR UNDERCUTTING

9.7.1 General

Undercutting is defined in 9.3.11. The acceptance standards in 9.7.2 supplement but do not replace visual inspection requirements found elsewhere in this standard.

9.7.2 Acceptance Standards

When visual and mechanical means are used to determine depth, undercutting adjacent to the cover or root bead shall not exceed the dimensions given in Table 4. When both

mechanical and radiographic measurements are available, the mechanical measurements shall govern.

10 Repair and Removal of Defects

10.1 AUTHORIZATION FOR REPAIR

10.1.1 Cracks

Cracked welds shall be removed from the line unless permitted by 9.3.10 or when the repair is authorized by the company. Cracks may be repaired provided the length of the crack is less than 8% of the weld length and a qualified repair welding procedure is used.

10.1.2 Defects Other Than Cracks

Defects in the root and filler beads may be repaired with prior company authorization. Defects in the cover pass may be repaired without prior company authorization. A qualified repair welding procedure is required to be used whenever a repair is made to a weld using a process different from that used to make the original weld or when repairs are made in a previously repaired area.

10.2 REPAIR PROCEDURE

When a repair welding procedure is required, the procedure shall be established and qualified to demonstrate that a weld with suitable mechanical properties and soundness can be produced. This shall be determined by destructive testing and the type and number of such tests shall be at the discretion of the company. The repair procedure, as a minimum, shall include the following:

10.2.1 Method of exploration of the defect.

10.2.2 Method of defect removal.

10.2.3 The repair groove shall be examined to confirm complete removal of the defect.

10.2.4 Requirements for preheat and interpass heat treatment.

10.2.5 Welding processes and other specification information contained in 5.3.2.

10.2.6 Requirement for interpass nondestructive testing.

10.3 ACCEPTANCE CRITERIA

10.3.1 Repaired areas shall be inspected by the same means previously used. If the company chooses, it may re inspect all of a weld containing a repair in the same manner allowed for inspection of any production weld (see 8.1 and 8.2). Repairs shall meet the standards of acceptability of Section 9.

Table 4—Maximum Dimensions of Undercutting

Depth	Length
> 0.031 in. (0.8 mm) or > 12.5% of pipe wall thickness, whichever is smaller.	Not acceptable.
> 0.016 in. (0.4 mm) but ≤ 0.031 in. (0.8mm) or > 6% but ≤ 12.5% of pipe wall thickness, whichever is smaller.	2 in. (50 mm) in a continuous 12 in. (300 mm) weld length or one-sixth the weld length, whichever is smaller.
≤ 0.016 in. (0.4 mm) or ≤ 6% of pipe wall thickness, whichever is smaller.	Acceptable, regardless of length.

10.4 SUPERVISION

10.4.1 The repair shall be made under the supervision of a technician experienced in repair welding techniques.

10.5 WELDER

10.5.1 The weld shall be made by a qualified welder.

11 Procedures for Nondestructive Testing

11.1 RADIOGRAPHIC TEST METHODS

11.1.1 General

Subsection 11.1 presents the requirements for producing radiographic images on film or other media through the use of x-rays or gamma rays. A detailed procedure for the production of images shall be established and recorded. Radiographic film produced by the use of this procedure shall have the density (see 11.1.10), clarity, and contrast required by this standard. Images produced by other systems shall have the requisite sensitivity to define clearly the essential wire diameter of the proper image quality indicator (IQI). The following criteria shall be used to evaluate images:

- An acceptable image quality that is free from fog and from processing irregularities that could mask the image of actual imperfections.
- The prescribed image quality indicator (IQI) and the essential wire diameter.
- A satisfactory identification system.
- An acceptable technique and setup.
- Compatibility with acceptance standards.

All requirements that refer to the quality of the resulting images shall apply equally to x-rays and gamma rays. The use of radiographic inspection and the frequency of its use shall be at the option of the company.

The company and the radiographic contractor should agree on the radiographic procedure or procedures to be used prior to the performance of production radiography. The company shall require the contractor to demonstrate that the proposed procedures produce acceptable images and shall require the contractor to use such procedures for production radiography.

11.1.2 Details of Procedure

11.1.2.1 General

The details of each radiographic procedure shall be recorded. A copy of the record shall be furnished to the company for its records. The record may be in the form of writing, a sketch, or both. As a minimum, each procedure shall include the applicable details listed in 11.1.2.2 and 11.1.2.3.

11.1.2.2 Film Radiography

As a minimum, the procedure for film radiography shall include the following details:

- Radiation source—the type of radiation source, the size of the effective source or focal spot, and the voltage rating of the x-ray equipment.
- Intensifying screens—the type and placement of the screens and, if lead is used, their thickness.
- Film—the film brand or type or both and the number of film in the holder or cassette. For multiple-film techniques, the way in which the film is to be viewed shall be specified.
- Exposure geometry—whether single-wall exposure for single-wall viewing (SWE/SWV), double-wall exposure for single-wall viewing (DWE/SWV), or double-wall exposure for double-wall viewing (DWE/DWV); the distance from the source or focal spot to the film; the relative positions of the film, weld, source, image quality indicators (IQI), and interval or reference markers; and the number of exposures required for radiography of a complete weld.
- Exposure conditions—whether milliamperere or curie minutes, the x-ray voltage or the input voltage and amperage, and the exposure time.
- Processing—whether automatic or manual; the time and temperature for development and the time for stop bath or rinsing, fixing, and washing; and drying details.
- Materials—the type and thickness range of material for which the procedure is suitable.
- Image quality indicators (IQI)—the type of material, identifying ASTM or ISO set, and essential wire diameter.
- Heat shields—material, thickness, and the distance from the film side of the heat shield to the pipe surface.

11.1.2.3 Other Imaging Media

As a minimum, the procedure for radiography using imaging media other than film shall include the following details:

- a. Radiation source—the type of radiation source, the size of the effective source or focal spot, and the voltage rating of the x-ray equipment.
- b. The image collection system used.
- c. The image processing system used.
- d. The image viewing system used.
- e. The image storage system used.
- f. Exposure geometry—whether SWE/SWV, DWE/SWV, or DWE/DWV; whether in motion or still imaging; the scanning speed for in motion imaging; the distance from the source or focal spot to the imager surface; the relative positions of the imager surface, weld, source, image quality indicators (IQI), and the intervals or reference markers; the amount of geometric magnification; the total magnification used for viewing; and the number of images required for radiography of a complete weld.
- g. Exposure conditions—whether milliamperes or curie minutes, the x-ray voltage or the input voltage and amperage, and when applicable, the exposure time.
- h. Materials—the type and thickness range of material for which the procedure is suitable.
- i. Image quality indicators (IQI)—the type of material, identifying ASTM or ISO set, and essential wire diameter.
- j. Heat shields—material, thickness, and the distance from the imaging side of the heat shield to the pipe surface.

11.1.3 Exposure Geometry

11.1.3.1 Film Radiography

When a radiographic source is centered in the pipe for exposing a butt weld, one exposure is adequate for the radiographic inspection of the complete weld (SWE/SWV). When the radiographic source is outside but not more than $\frac{1}{2}$ in. (13 mm) from the weld surface, at least three exposures separated by 120° shall be made for the radiographic inspection of a complete weld (DWE/SWV). When the radiographic source is outside and more than $\frac{1}{2}$ in. (13 mm) from the weld surface, at least four exposures separated by 90° shall be made for the radiographic inspection of a complete weld (DWE/SWV). When the outside diameter of the piping containing the weld is 3.500 in. (88.9 mm) or less, a DWE/DWV procedure may be used. When this procedure is used and the radiation beam is offset so that the source-side and film-side portions of the weld do not overlap in the areas of the radiograph being evaluated, at least two exposures separated by 90° shall be made for the radiographic inspection of a complete weld. When the source-side and film-side portions of the weld are superimposed, at least three exposures separated by 60° shall be made for the radiographic inspection of a complete weld.

When smaller diameter, thicker wall pipe is radiographed, additional exposures should be made to minimize the distortion of imperfection images at the ends of the radiographs.

The minimum distance between the source or focal spot and the source side of the object being radiographed shall be determined by the following formula (using constant units of measurement):

$$D = St/k$$

where

D = minimum distance, in inches, between the source or focal spot and the source side of the object being radiographed,

S = size, in inches, of the effective source or focal spot,

t = thickness of the weld, in inches, including reinforcement, plus the distance between the film side of the weld and the film,

k = geometric unsharpness factor.

When t is determined for SWE/SWV and DWE/SWV procedures, the thickness of the single wall and its weld reinforcement shall be used. When t is determined for DWE/DWV procedures, the outside diameter of the weld (that is, the outside diameter of the pipe plus twice the average height of the weld crown) shall be used. k is defined as 0.02 in. (0.5 mm) for material with a thickness of less than or equal to 2.000 in. (50.8 mm).

11.1.3.2 Other Imaging Media

For in-motion imaging, the exposure geometry shall be evaluated at the maximum scanning speed to be used during the radiographic inspection of the complete weld.

11.1.4 Type of Image Quality Indicators (IQI)

Image quality indicators (IQI) shall conform to the requirements of either ASTM E 747 or ISO 1027 wire IQI. The company shall define which type of IQI (ASTM or ISO) is to be used. The IQI shall be made of a material that is radiographically similar to the material being welded.

11.1.5 Selection of Image Quality Indicators (IQI)

The IQI shall consist of either a series of six (6) wires for ASTM E747 wire type or a series of seven (7) wires for ISO wire type IQI, arranged in order of increasing diameter. The essential wire diameter to be used, based on the thickness of the weld is shown in Table 5 for ASTM E 747 wire type IQI and Table 6 for ISO wire type IQI. At the radiographic contractor's option, smaller wire diameter IQI than those speci-

fied above may be used, provided the required radiographic sensitivity is obtained.

Note: For purposes of IQI selection, the thickness of the weld shall mean nominal wall thickness plus the weld reinforcement (internal plus external combined).

The radiographic images of the IQI identifying style number and ASTM set letter or ISO designation shall appear clearly. The image of the essential wire diameter shall appear clearly across the entire area of interest.

11.1.6 Placement of Image Quality Indicators (IQI)

11.1.6.1 Film

The IQI shall be placed as follows:

- a. When a complete weld is radiographed in a single exposure using a source inside the piping, at least four IQI placed across the weld and spaced approximately equally around the circumference shall be used. For the DWE/DWV procedure, one IQI shall be placed on the source side of the pipe and across the weld so that the essential wire image is superimposed onto the weld images. For the DWE/SWV or SWE/SWV procedures requiring multiple exposures for complete inspection of the weld, and where the length of film to be interpreted is greater than 5 in. (130 mm), two IQI placed across the weld and located on the film side shall be used. One shall be within 1 in. (25 mm) of the end of the film length to be interpreted and the other shall be at the center of the film. When the film length to be interpreted is 5 in. (130 mm) or less, one IQI shall be placed on the film side, across the weld and located at the center of the length to be interpreted. When a repaired weld is radiographed, an additional IQI shall be placed across each repaired area.
- b. When it is not practical to place an IQI on the weld due to weld configuration or size, the IQI may be placed on a separate block. Separate blocks shall be made of the same or radiographically similar material and may be used to facilitate IQI positioning. The thickness of the separate block material should be the same as the thickness of the weld.
- c. Heat shields: IQI may be placed on a heat shield rather than in contact with the pipe, provided that the acceptability of such IQI placement is demonstrated during procedure qualification.

11.1.6.2 Other Imaging Media

For imaging media other than film, IQI placement shall be the same as that required by 11.1.6.1. The IQI may be placed above the surface of the pipe or held in position between the surface of the pipe and the imager by a fixture attached to the imager or scanning device. Acceptability of such IQI placement shall be demonstrated during procedure qualification.

11.1.7 Production Radiography

Only Level II or III radiographers shall interpret the radiographic images of production welds. Radiographers shall report to the company all defects observed in the images unless the company requires that all imperfections observed be reported. The radiographer shall indicate whether the weld meets the requirements of Section 9. The company shall determine the final disposition of the weld.

11.1.8 Identification of Images

Images shall be clearly identified by the use of lead numbers, lead letters, markers, or other identification so that the proper weld and any imperfections in it can be quickly and accurately located. The company may specify the identification procedure to be used. Whenever more than one image is used to inspect a weld, identification markers shall appear on each image, and adjacent images shall overlap. The last reference marker on each end of the image shall appear on the appropriate adjacent images in a way that establishes that no part of the weld has been omitted.

11.1.9 Storage of Film and Other Imaging Media

11.1.9.1 Film

All unexposed films shall be stored in a clean, dry place where the conditions will not detrimentally affect the emulsion. If any question arises about the condition of the unexposed film, sheets from the front and back of each package or a length of film equal to the circumference of each original roll shall be processed in the normal manner without exposure to light or radiation. If the processed film shows fog, the entire box or roll from which the test film was removed shall be discarded, unless additional tests prove that the remaining film in the box or roll is free from pre-exposure fog exceeding 0.30 H&D transmitted density for transparent-based film or 0.05 H&D reflected density for opaque-based film.

Note: H&D refers to the Hurter-Driffield method of defining quantitative blackening of the film.

11.1.9.2 Other Imaging Media

Imaging media other than film shall be stored in strict accordance with the manufacturer's recommendations.

11.1.10 Film Density

11.1.10.1 Film Density

Except for small localized areas caused by irregular weld configurations, the transmitted H&D density in the area of interest of transparent-based film shall not be less than 1.8 nor greater than 4.0. The reflected H&D density for opaque-based film shall not be less than 0.5 nor greater than 1.5. Transmitted H&D densities through small localized areas may exceed

Table 5—Weld Thickness Versus Diameter of ASTM E 747 Wire Type IQI

Weld Thickness		Essential Wire Diameter		ASTM Set Letter
Inches	Millimeters	Inches	Millimeters	
0 – 0.250	0 – 6.4	0.008	0.20	A
> 0.250 – 0.375	> 6.4 – 9.5	0.010	0.25	A or B
> 0.375 – 0.500	> 9.5 – 12.7	0.013	0.33	B
> 0.500 – 0.750	> 12.7 – 19.1	0.016	0.41	B
> 0.750 – 1.000	> 19.1 – 25.4	0.020	0.51	B
> 1.000 – 2.000	> 25.4 – 50.8	0.025	0.64	B

Table 6—Weld Thickness Versus Diameter of ISO Wire Type IQI

Weld Thickness		Essential Wire Diameter		Wire Identity
Inches	Millimeters	Inches	Millimeters	
0 – 0.250	0 – 6.4	0.008	0.20	13
> 0.250 – 0.375	> 6.4 – 9.5	0.010	0.25	12
> 0.375 – 0.500	> 9.5 – 12.7	0.013	0.33	11
> 0.500 – 0.750	> 12.7 – 19.1	0.016	0.41	10
> 0.750 – 1.000	> 19.1 – 25.4	0.020	0.51	9
> 1.000 – 2.000	> 25.4 – 50.8	0.025	0.64	8

these limits; however, minimum densities shall not be less than 1.5 and maximum densities shall not exceed 4.2; reflected H&D density shall not be less than 0.25 and shall not exceed 1.8.

11.1.10.2 Film Viewing Equipment

The viewing equipment (illuminator) shall be of the variable high intensity type and shall be capable of viewing film densities within the range specified in 11.1.10.1. It shall be equipped to prevent light, coming from around the outer edge of the radiograph or through low density portions of the radiograph, from interfering with interpretations.

11.1.10.3 Film Viewing Facilities

Viewing facilities shall provide subdued background lighting of an intensity that will not cause troublesome reflections, shadows, or glare on the radiograph.

11.1.11 Image Processing

When requested by the company, film or other imaging media shall be processed, handled, and stored so that the images are interpretable for at least 3 years after they are produced.

11.1.12 Image Processing Area

The image processing area and all accessories shall be kept clean at all times.

11.1.13 Radiation Protection

The radiographer shall be responsible for the protection and monitoring of every person working with or near radia-

tion sources. The protection and monitoring shall comply with applicable federal, state, and local regulations.

11.2 MAGNETIC PARTICLE TEST METHOD

When magnetic particle testing is specified by the company, a detailed written procedure for magnetic particle testing shall be established that meets the requirements of ASTM E 709. The company and the nondestructive testing contractor should agree on the magnetic particle testing procedure or procedures prior to the performance of production testing.

The company shall require the contractor to demonstrate that the proposed procedures will produce acceptable results and shall require the contractor to use such procedures for production testing.

11.3 LIQUID PENETRANT TEST METHOD

When liquid penetrant testing is specified by the company, a detailed written procedure for liquid penetrant testing shall be established that meets the requirements of ASTM E 165. The company and the nondestructive testing contractor should agree on the liquid penetrant testing procedure or procedures prior to the performance of production testing.

The company shall require the contractor to demonstrate that the proposed procedures will produce acceptable results and shall require the contractor to use such procedures for production testing.

11.4 ULTRASONIC TEST METHODS

11.4.1 General

When ultrasonic testing is specified by the company for the inspection of new and/or in-service circumferential butt

welds, the requirements of this section shall apply. A detailed procedure for use of the individual ultrasonic techniques shall be established and recorded. The use of ultrasonic testing and the scope of its use shall be at the option of the company.

The company and the ultrasonic contractor should agree on the ultrasonic procedures before the performance of production testing. The company shall require the ultrasonic contractor to demonstrate the proposed procedures to produce acceptable and accurate results and shall require the contractor to use such procedures for production testing.

Caution is advised when this method is applied to in-service weld inspection due to potential parent material and surface imperfections that can interfere with the use of the ultrasonic technique.

All surfaces to be ultrasonically scanned shall be in the uncoated condition. For new construction projects, the coating cutback (bare pipe length) at pipe ends necessary for ultrasonic scanning should be specified prior to the pipe being coated. Pipe seams should be ground flush with the pipe surface for the distance necessary for ultrasonic scanning.

11.4.2 Details of Procedure

11.4.2.1 General

The details of each ultrasonic procedure shall be recorded. A copy of the record shall be furnished to the company for its records. The record shall be in the form of both writing and sketches. As a minimum, each procedure shall include the applicable details listed in 11.4.2.2.

11.4.2.2 Ultrasonic Procedure

As a minimum the procedure for ultrasonic testing of welds shall include the following specific application details:

- a. Type of welds to be tested, joint preparation dimensions and welding processes.
- b. Material type (i.e., size, grade, thickness, process of manufacturing per API Spec 5L).
- c. Scanning surface preparation/condition.
- d. Stage at which examination is to be performed.
- e. Ultrasonic instrument/system and probes (i.e., manufacturer, type, size, etc.).
- f. Automatic or manual.
- g. Couplant.
- h. Testing technique:
 1. Angles.
 2. Frequencies (MHz).
 3. Temperatures and ranges.
 4. Scanning patterns and speeds.
 5. Reference datum and location markers (i.e., root face and circumferential locations).
- i. Reference standards—detail sketches showing plan-view and cross-section-view dimensions of production-material reference-standard blocks and all reference reflectors.

j. Calibration requirements—the interval at which calibration of the instrument or system is required, the sequence of set-up calibration prior to inspecting welds, including all standard calibration blocks to be used, the reference sensitivity reflectors to be used, the reference sensitivity-level setting (i.e., DAC or TCG), and the intervals for verification of calibration settings.

k. Scanning level—the sensitivity setting in decibels (dB) to be added to the reference sensitivity for scanning.

l. Evaluation level—the level or height of echoes detected during scanning at which further evaluation is required, and any sensitivity adjustment to be made before evaluating for acceptance or rejection.

m. Recording of results—type of record (e.g., sketch, thermal printer, compact disc, etc.) and whether all reflectors or only unacceptable reflectors will be recorded.

n. Ultrasonic Examination Report—an example of the examination reports.

11.4.3 Ultrasonic Testing Personnel Requirements

An NDT Level III in the ultrasonic method shall develop the application technique and prepare and approve the testing procedure. Only Level II or III certified personnel shall calibrate equipment and interpret the test results. NDT Level II or III personnel in ultrasonics shall perform the test and evaluate the results per the acceptance/rejection criteria.

The ultrasonic testing personnel shall perform examinations in accordance with qualified and approved procedures (see 11.4.4). Personnel responsible for testing shall be capable of determining the acceptability of circumferential butt welds in accordance with the acceptance criteria as listed in 9.6.

The company has the right, at any time, to require personnel to demonstrate their capabilities to perform to the requirements of the qualified procedure.

11.4.4 Demonstration of the Testing Procedure

Prior to final written approval, the company shall require the contractor to demonstrate the application of the procedure and ultrasonic systems. A procedure demonstration report shall be generated and the results documented prior to use on actual field welds. The demonstration process shall be as follows:

- a. Welds containing defects and acceptable imperfections shall be prepared from actual production pipe material samples utilizing an approved welding procedure specification. Changes in wall thickness, bevel design, acoustic velocity, welding process, repair welds, and other variables that can have an effect on the detectability and resolution of the system shall require additional demonstration welds from other corresponding approved welding procedures. Welder qualification welds may be used.
- b. Radiographs shall be made of the welds and the results documented.

c. The UT procedure shall be applied, within the detailed temperature ranges, and the results documented and compared with the radiographs.

d. Differences in detection results shall be documented. (Differences in detectability and resolution between ultrasonics and radiography shall be noted.) If required by the company, destructive testing of the weld sample shall be made to discover or confirm the results.

e. Use of the UT procedure on production welding shall be based on the capability of the implemented UT method/technique/systems to: 1) circumferentially locate, 2) size for length, 3) determine depth from O.D. surface, and 4) axially (weld cross section) locate required imperfections/defects in the test samples. In addition, the procedure must accurately determine the acceptability of welds in accordance with the criteria listed in 9.6 and 11.4.7.

11.4.5 API Sensitivity Reference Standard

Manual ultrasonic testing sensitivity shall be based on a two or three point reference level (i.e., distance amplitude correction [DAC] or time corrected gain [TCG]) derived from an N10 notch introduced into a sample of the pipe to be inspected. (See Figures 21A and 21B.) The highest point of the DAC/TCG shall not be less than 80% of full screen height. The reference standard shall also be used to determine the actual sound beam velocity, refracted angle and sound path distance in the pipe material to be inspected. Unknown velocity and refracted angle shall be determined when welds in pipe of different chemistry specifications, wall thickness, diameter or from more than one pipe and rolling or piercing manufacturer are to be inspected. This may be accomplished by using two probes of the same nominal angle and frequency with the probes directed toward one another. (See Figure 21C.) When a difference is noted in velocity, angle, or sound path distance another reference standard shall be made from the different pipe material.

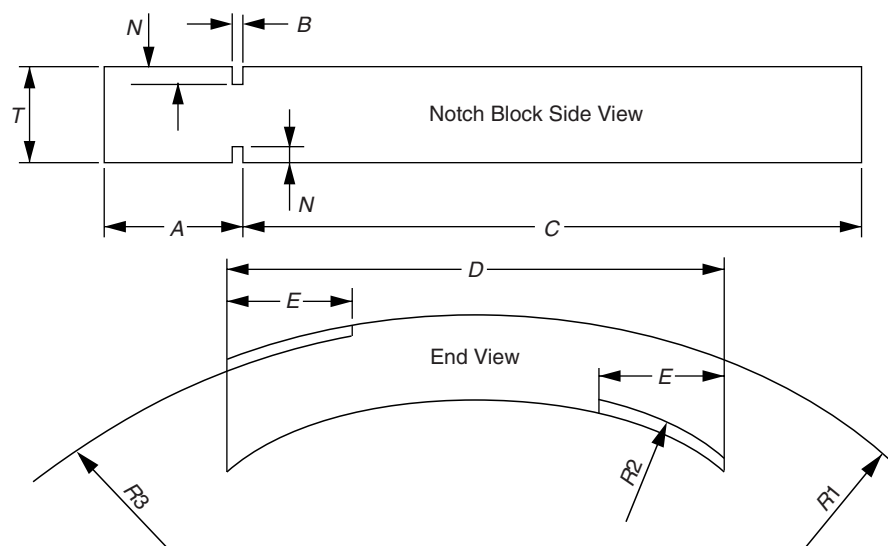

Dimensions:

- T Nominal pipe wall thickness
- N Notch depth = 10% T plus or minus 10% of notch depth
- A 2 in. (50 mm) minimum length
- B 0.125 in. (3.2 mm) maximum notch width
- C 11.35 T plus 2 in. (50 mm) minimum length
- D 3.1 in. (80 mm) minimum width
- E 1 in. (25 mm) minimum notch length
- $R1$ Outside radius of pipe
- $R2$ Radius of inside notch = $R1$ minus 0.9 T

Figure 21A—Reference Block for Manual UT

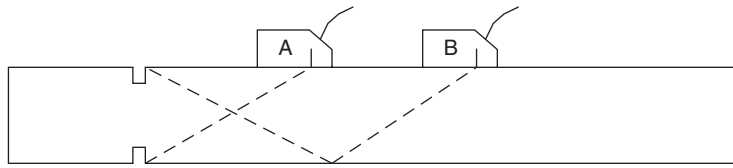

Position the transducer in line with the outside notch at double the distance used to peak up the inside notch (Position B). Verify that the outside notch echo peak is at or near zero depth reading. This will establish that refracted angle and velocity settings are sufficiently accurate.

Figure 21B—Establishing Distance, Refracted Angle, and Velocity

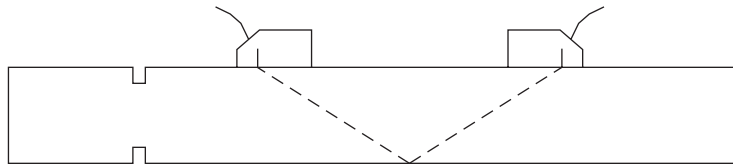

Using two transducers of equal angle and frequency, one transmitting and the other receiving, maximize (peak up) the echo received. Measure the surface distance between the transducer exit points. Half the surface distance divided by measured wall thickness equals the refracted angle tangent. Without changing instrument settings, repeat this process on pipe with unknown velocity, refracted angle, and attenuation to determine any differences.

Figure 21C—Transfer Procedure

For automated ultrasonic testing and when required by the company for manual ultrasonic testing, flat bottom holes shall be machined into a sample of the pipe to be inspected. This sample shall be used as calibration reflectors in addition to the N10 notches at the inside and outside surfaces. The diameter of each flat bottom hole should be approximately equal to the thickness of one welding fill pass. The flat reflecting surface of each hole shall be installed at the same angle and position as the weld joint preparation for each fill pass required by the welding procedure. Additionally, planar reflectors or flat bottom holes shall be installed at the weld center-line position with their flat reflecting surfaces vertical to the weld. All reflectors should be spaced apart so that no two will be within the beam spread of one probe simultaneously.

For testing on other than new construction, a pipe sample of the same grade, wall thickness, and outside diameter as the pipe to be inspected shall be used to make the reference standard. A transfer technique using probes of the same nominal angles and frequencies to be used for inspection shall be carried out to determine actual full skip distance, actual refracted angle, and attenuation in the material to be inspected. (See Figure 21C.)

11.4.6 Parent Material Ultrasonic Testing

After completion of the circumferential butt weld, but prior to its ultrasonic testing, a compression wave test of the parent material on both sides of the weld (minimum distance = 1.25, the longest surface skip distance to be used) shall be performed. All interfering partial and full beam reflectors shall be noted (datum location and distance from the weld edge) and recorded on the examination record.

The company may elect to waive this requirement in lieu of lamination checks performed by the mill.

11.4.7 Scanning and Evaluation Level

11.4.7.1 Parent Material Ultrasonic Testing

Manual compression wave testing of parent material shall be performed with the second backwall echo from the reference standard (see Figure 21A) adjusted to at least 80% of full screen height.

Automated ultrasonic testing of the parent material shall be performed using the same calibration method and evaluation level as that used for manual compression wave, or a different technique if demonstrated to be equal to or better than the manual method.

11.4.7.2 Manual Ultrasonic Weld Testing

Manual ultrasonic weld testing shall be performed at a scanning sensitivity of DAC/TCG reference sensitivity plus 6 dB minimum. All indications that exceed 50% of DAC/TCG screen height shall be evaluated.

Evaluation sensitivity for manual ultrasonic weld testing should be DAC/TCG reference sensitivity plus 6 dB with an evaluation level for all indications at 50% of DAC/TCG screen height.

After the reference sensitivity, scanning sensitivity, and evaluation sensitivity and levels have been established, they shall be qualified, then incorporated into the final procedure and in the final qualification report.

11.4.7.3 Automated Ultrasonic Weld Testing

Automated ultrasonic weld testing should be performed at a scanning sensitivity of 80% screen height reference sensitivity plus 4 dB when using the pulse-echo technique. Evaluation sensitivity should be the same as scanning sensitivity.

Evaluation level screen height (recording threshold) should be 40% of full screen height using the automated pulse-echo technique.

Other automated techniques, reference reflectors, reference sensitivities, scanning sensitivities, evaluation sensitivities, and evaluation levels may be used if demonstrated to be equivalent to the pulse-echo technique for the detection and evaluation of weld imperfections.

11.4.8 Production Ultrasonic Testing

Ultrasonic technicians shall report to the company all defects unless the company requires that all observed (evaluation level and above) indications be reported. The company shall determine the final disposition of the weld.

11.4.9 Identification of Reported Indications

The ultrasonic testing report of inspected welds shall include the weld number, datum location, length, depth from the O.D. surface, and defect classification (linear, transverse, or volumetric) of all reported indications.

12 Mechanized Welding with Filler Metal Additions

12.1 ACCEPTABLE PROCESSES

Mechanized welding shall be performed using one or more of the following processes:

- a. Submerged-arc welding.
- b. Gas metal-arc welding.
- c. Gas tungsten-arc welding.
- d. Flux-cored arc welding with or without external shielding.
- e. Plasma arc welding.

12.2 PROCEDURE QUALIFICATION

Before production welding is started, a detailed procedure specification shall be established and qualified to demonstrate that welds with suitable mechanical properties (such as strength, ductility, and hardness) and soundness can be made by the procedure. Two pipe lengths, full joints or nipples, shall be joined by following all the details of the procedure specification. The quality of the weld shall be determined by both destructive and nondestructive testing and shall meet the requirements of 5.6, except Nick-breaks (5.6.3) shall not be required, and Section 9, respectively. These procedures shall be adhered to except where a change is specifically authorized by the company, as provided for in 12.5.

12.3 RECORD

The details of each qualified procedure shall be recorded. This record shall show complete results of the procedure qualification test. Forms similar to those shown in Figures 1 and 2 should be used. This record shall be maintained as long as the procedure is in use.

12.4 PROCEDURE SPECIFICATION

12.4.1 General

The procedure specification shall include all the information that is pertinent to setting up and maintaining the proper operation of the equipment, as specified in 12.4.2.

12.4.2 Specification Information

12.4.2.1 Process

The specific process or combination of processes used shall be identified. This shall include the type of welding technology and a description of the equipment to be utilized.

12.4.2.2 Pipe and Fitting Materials

The materials to which the procedure applies shall be identified. API Spec 5L pipe, as well as materials that conform to acceptable ASTM specifications, may be grouped (see 5.4.2.2), provided that the qualification test is made on the material with the highest specified minimum yield strength in the group.

12.4.2.3 Diameters

The range of outside diameters over which the procedure is applicable shall be identified.

12.4.2.4 Wall Thickness Group and Number and Sequence of Beads

The range of wall thicknesses over which the procedure is applicable shall be identified, as shall the range of number of beads required for the thicknesses and the machine used for each bead.

12.4.2.5 Joint Design

The specification shall include a sketch or sketches of the joint that show the type of joint (e.g., V or U), the angle of bevel, and the size of the root face and root opening. If a backup is used, the type shall be designated.

12.4.2.6 Filler Metal

The size and AWS classification number of the filler metal, if available, shall be designated.

12.4.2.7 Electrical Characteristics

The current and polarity shall be designated, and the range of voltage and amperage for each size or type of electrode used shall be specified.

12.4.2.8 Position

The specification shall designate roll or position welding.

12.4.2.9 Direction of Welding

For position welding only, the specification shall designate whether the welding is to be performed in an uphill or downhill direction.

12.4.2.10 Time between Passes

The maximum time between the completion of the root bead and the start of the second bead, as well as the maximum time between the completion of the second bead and the start of other beads, shall be designated.

12.4.2.11 Type of Lineup Clamp

The specification shall designate whether the lineup clamp is to be internal or external or if no clamp is required.

12.4.2.12 Cleaning

The specification shall describe the joint end and interpass cleaning required.

12.4.2.13 Pre-heat Treatment

The methods, width to be heated, minimum temperature at the start of the weld, and minimum ambient temperature below which preheat treatment is required shall be specified.

12.4.2.14 Post-heat Treatment

The methods, width to be heated, minimum and maximum temperature, time at temperature, and temperature control methods for post-heat treatment shall be specified.

12.4.2.15 Shielding Gas and Flow Rate

The composition of the shielding gas and the range of flow rates shall be designated.

12.4.2.16 Shielding Flux

The AWS classification number, if available, or the brand number of the shielding flux shall be designated.

12.4.2.17 Speed of Travel

The range for speed of travel, in inches (Millimeters) per minute, shall be specified for each pass.

12.4.2.18 Other Factors

Other important factors that may be necessary for proper operation of the process or that may affect the quality of the work produced shall be designated. These may include the location and angle of arc for submerged arc welding, the contact-tube-to-work distance, and the oscillation width and frequency.

12.5 ESSENTIAL VARIABLES

12.5.1 General

A welding procedure must be re-established as a new procedure specification and must be completely requalified when any of the essential variables listed in 12.5.2 are changed. Changes other than those listed in 12.5.2 may be made in the procedure without the need for requalification, provided the procedure specification is revised to show the changes.

12.5.2 Changes Requiring Requalification

12.5.2.1 Welding Process

A change from the welding process established in the procedure specification constitutes an essential variable.

12.5.2.2 Pipe Material

A change in pipe material constitutes an essential variable. For the purposes of this standard, all carbon steels shall be grouped as follows:

- Specified minimum yield strength less than or equal to 42,000 psi (290 MPa).
- Specified minimum yield strength greater than 42,000 psi (290 MPa) but less than 65,000 psi (448 MPa).
- For carbon steels with a specified minimum yield strength greater than or equal to 65,000 psi (448 MPa), each grade shall receive a separate qualification test.

Note: The groupings specified above in 12.5.2.2 do not imply that base materials or filler metals of different analyses within a group may be indiscriminately substituted for a material that was used in the qualification test without consideration of the compatibility of the base materials and filler metals from the standpoint of metallurgical and mechanical properties and requirements for pre- and post-heat treatment.

12.5.2.3 Joint Design

A major change in joint design (for example, from V groove to U groove) or any change beyond the range established in the procedure specification for such factors as spacing, root face, and angle of bevel constitutes an essential variable.

12.5.2.4 Wall Thickness

A change in wall thickness beyond the range established in the procedure specification constitutes an essential variable.

12.5.2.5 Pipe Diameter

A change in pipe outside diameter beyond the range established in the procedure specification constitutes an essential variable.

12.5.2.6 Filler Metal

The following changes in filler metal constitute essential variables:

- a. A change from one filler-metal group to another (see Table 1).
- b. For pipe materials with a specified minimum yield strength greater than or equal to 65,000 psi (448 MPa), a change in the AWS classification of the filler metal (see 5.4.2.2).

Changes in filler metal may be made within the groups specified in 12.5.2.2, items a and b. The compatibility of the base material and the filler metal should be considered from the standpoint of mechanical properties.

12.5.2.7 Size of Filler-metal Wire

A change in the size of the filler-metal wire constitutes an essential variable.

12.5.2.8 Time between Passes

An increase in the maximum time between completion of the root bead and the start of the second bead constitutes an essential variable.

12.5.2.9 Direction of Welding

A change in the direction of welding from vertical uphill to vertical downhill, or vice versa, constitutes an essential variable.

12.5.2.10 Shielding Gas and Flow Rate

A change from one shielding gas to another or from one mixture of gases to another constitutes an essential variable. An increase or decrease in the range of flow rates established for the shielding gas also constitutes an essential variable.

12.5.2.11 Shielding Flux

Refer to Table 1, Footnote a, for changes in shielding flux that constitute essential variables.

12.5.2.12 Speed of Travel

A change in the range for speed of travel constitutes an essential variable.

12.5.2.13 Pre- and Post-heat Treatment Requirements

A change in pre- or post-heat treatment requirements constitutes an essential variable.

12.5.2.14 Electrical Characteristics

A change in electrical characteristics constitutes an essential variable.

12.5.2.15 Orifice Diameter or Orifice Gas Composition

For plasma arc welding, a change in orifice gas nominal composition or a change in orifice diameter.

12.6 QUALIFICATION OF WELDING EQUIPMENT AND OPERATORS

Each welding operator shall be qualified by producing an acceptable weld using the qualified welding procedure. The completed weld shall be tested by destructive methods, non-destructive methods, or both, and shall meet the requirements of 6.4 through 6.7 except Nick-breaks (see 6.5.3) shall not be required. Prior to the start of welding, each welding operator shall have received adequate training in the operation of the welding equipment. If the welding procedure involves more than one operation, welding operators shall be qualified on the type of welding equipment that will be used in production welding. Changes in the essential variables described in 12.6.1 require requalification of the welding operator.

12.6.1 Scope

- a. A change from one welding process, mode of transfer, polarity or method of application to another welding process or combination of processes. (Example would be short arc, pulse arc, spray arc, gas tungsten arc, etc.)
- b. A change in the direction of welding from vertical uphill to vertical downhill or vice versa.
- c. A change in the filler metal type (solid wire, metal core, flux core).
- d. A change from one outside diameter group to another.
 1. Outside diameter less than 12.75 in. (328.9 mm).
 2. Outside diameter equal to or greater than 12.75 in. (328.9 mm).
- e. Welding operator shall qualify on the heaviest wall thickness.
- f. A change in position from that for which the welder/operator has already qualified (for example a change from rolled to fixed or a change from vertical to horizontal).

- g. A change in welding bug manufacturer or model.
- h. A change in the method of applying the root bead. (Example external root versus internal root.)
- i. A major change in joint design (for example, from a V groove to a U groove or J groove) or any change beyond the range established. For such factors as spacing, root face, and angle of bevel constitutes an essential variable.
- j. At the option of the company, welders/operators whose work is limited to specific weld passes in a multipass buttweld shall qualify by demonstrating their ability to weld those specific passes in accordance with a qualified welding procedure specification, with the other weld passes necessary to make complete welds being made by others. Welders shall be qualified if all tests are acceptable.

12.7 RECORDS OF QUALIFIED OPERATORS

A record shall be made of the tests required by 12.6 and of the detailed results of each test. A form similar to that shown in Figure 2 should be used. (This form should be developed to suit the needs of the company but must be sufficiently detailed to demonstrate that the qualification test meets the requirements of this standard.) A list of qualified operators and the procedures for which they are qualified shall be maintained. An operator may be required to requalify if a question arises about their competence.

12.8 INSPECTION AND TESTING OF PRODUCTION WELDS

Production welds shall be inspected and tested in accordance with Section 8.

12.9 ACCEPTANCE STANDARDS FOR NONDESTRUCTIVE TESTING

The acceptance standards for nondestructive testing shall be in accordance with Section 9 or, at the company's option, Appendix A.

12.10 REPAIR AND REMOVAL OF DEFECTS

Repair and removal of defects shall be in accordance with Section 10.

12.11 RADIOGRAPHIC TESTING

Radiographic testing shall be in accordance with 11.1.

13 Automatic Welding Without Filler-metal Additions

13.1 ACCEPTABLE PROCESSES

Automatic welding without filler-metal additions shall be done using the flash butt-welding process.

13.2 PROCEDURE QUALIFICATION

13.2.1 Procedure

Before production welding is started, a detailed procedure specification shall be established and qualified to demonstrate that welds with suitable mechanical properties (such as strength, ductility, and hardness) and soundness can be made by the procedure. At least two welds shall be made by joining pipe lengths, full joints, or nipples and by following all the details of the procedure specification. The quality of the weld shall be determined by both destructive and nondestructive testing and shall meet the requirements of 13.2.3 and 13.9. These procedures shall be adhered to except where a change is specifically authorized by the company, as provided for in 13.5.

13.2.2 Radiography Prior to Mechanical Testing

Each procedure qualification weld shall meet the requirements of 13.9 prior to being submitted for mechanical testing.

13.2.3 Mechanical Testing of Butt-welded Joints

13.2.3.1 General

Mechanical test specimens shall be cut from the weld joint as shown in Figures 22, 23, and 24. The minimum number of specimens and the tests to which they are to be subjected are given in Table 7. These specimens shall be prepared and tested as specified in 13.2.3.2 through 13.2.3.4.

13.2.3.2 Tensile-strength Tests

13.2.3.2.1 Preparation

Tensile-strength test specimens shall be prepared in accordance with 5.6.2.1.

13.2.3.2.2 Method

Tensile-strength test specimens shall be tested in accordance with 5.6.2.2.

Table 7—Type and Number of Test Specimens for Procedure Qualification Test (Flash Weld Only)

Outside Diameter of Pipe		Number of Specimens				Total
		Tensile Strength	Nick-break		Side Bend	
Inches	Millimeters		Two inch	Standard		
> 18 – 24	> 457 – 610	4	16	0	4	24
> 24 – 30	> 610 – 762	4	24	0	4	32
> 30	> 762	4	32	0	4	40

13.2.3.2.3 Requirements

The tensile-strength of the weld, including the fusion zone of each specimen, shall be greater than or equal to the specified minimum tensile-strength of the pipe material but need not be greater than or equal to the actual tensile-strength of the material. If the specimen breaks outside the weld and fusion zone (i.e., in the parent pipe material) and meets the minimum tensile-strength requirements of the specification, the weld shall be accepted as meeting the requirements.

If the specimen breaks in the weld or fusion zone, the observed strength is greater than or equal to the specified minimum tensile-strength of the pipe material, and the weld meets the requirements for soundness given in 13.2.3.3.3, the weld shall be accepted as meeting the requirements.

13.2.3.3 Nick-break Test

13.2.3.3.1 Preparation

The number of 2-in. Nick-break specimens required by Table 7 shall be prepared in accordance with Figure 25. The sides of the specimen shall be macro-etched to locate the fusion line. The sides of the specimen shall be notched along the fusion line with a saw; each notch shall be approximately $\frac{1}{8}$ in. (3 mm) deep. In addition, the inside- and outside diameter weld reinforcement shall be notched to a depth of not more than $\frac{1}{16}$ in. (1.6 mm), measured from the weld surface.

13.2.3.3.2 Method

Nick-break specimens shall be tested in accordance with 5.6.3.2.

13.2.3.3.3 Requirements

The exposed surfaces of each Nick-break specimen shall show complete penetration and fusion. Slag inclusions shall not exceed $\frac{1}{8}$ in. (3 mm) in length or width. There shall be at least $\frac{1}{2}$ in. (13 mm) of sound weld metal between adjacent slag inclusions.

13.2.3.4 Side-bend Test

13.2.3.4.1 Preparation

Side-bend specimens shall be prepared in accordance with 5.6.5.1.

13.2.3.4.2 Method

Side bend specimens shall be tested in accordance with 5.6.5.2.

13.2.3.4.3 Requirements

The requirements for the performance of side-bend specimens shall be in accordance with 5.6.4.3.

13.3 RECORD

The details of each qualified procedure shall be recorded on a form incorporating, as a minimum, all of the items included in 13.4. This record shall show complete results of the procedure qualification test and shall be maintained as long as the procedure is in use.

13.4 PROCEDURE SPECIFICATION

The procedure specification shall include all the information that is pertinent to setting up and maintaining the proper operation of the equipment as indicated in the following items:

- a. Welding process.
- b. Pipe material.
- c. Pipe wall thickness and outside diameter.
- d. Pipe end preparation and outside diameter.
- e. Preparation of the pipe, including grinding of the pipe seam weld, if any, and cleaning of the pipe ends for electrical contact.
- f. Welding position.
- g. Requirements for preheat treatment.
- h. Requirements for cleaning and inspection of contact shoes.
- i. Range of welding voltage, which shall be recorded on a strip chart.
- j. Range of welding amperage, which shall be recorded on a strip chart.
- k. Range of axial speed, which shall be recorded on a strip chart.
- l. Time intervals in weld cycle, which shall be identified and recorded on a strip chart.
- m. Range of upset stroke, which shall be recorded on a strip chart.
- n. Time delay before removal of clamps.
- o. Method of removing internal flash.
- p. Method of removing external flash.
- q. Requirements for post-heat treatment, including heating time, maximum temperature, time of temperature, method of determining heating around circumference, and cooling rate.

13.5 ESSENTIAL VARIABLES

13.5.1 General

A welding procedure must be re-established as a new procedure specification and must be completely requalified when any of the essential variables listed in 13.5.2 are changed. Changes other than those given in 13.5.2 may be made in the procedure without the need for requalification, provided the procedure specification is revised to show the changes.

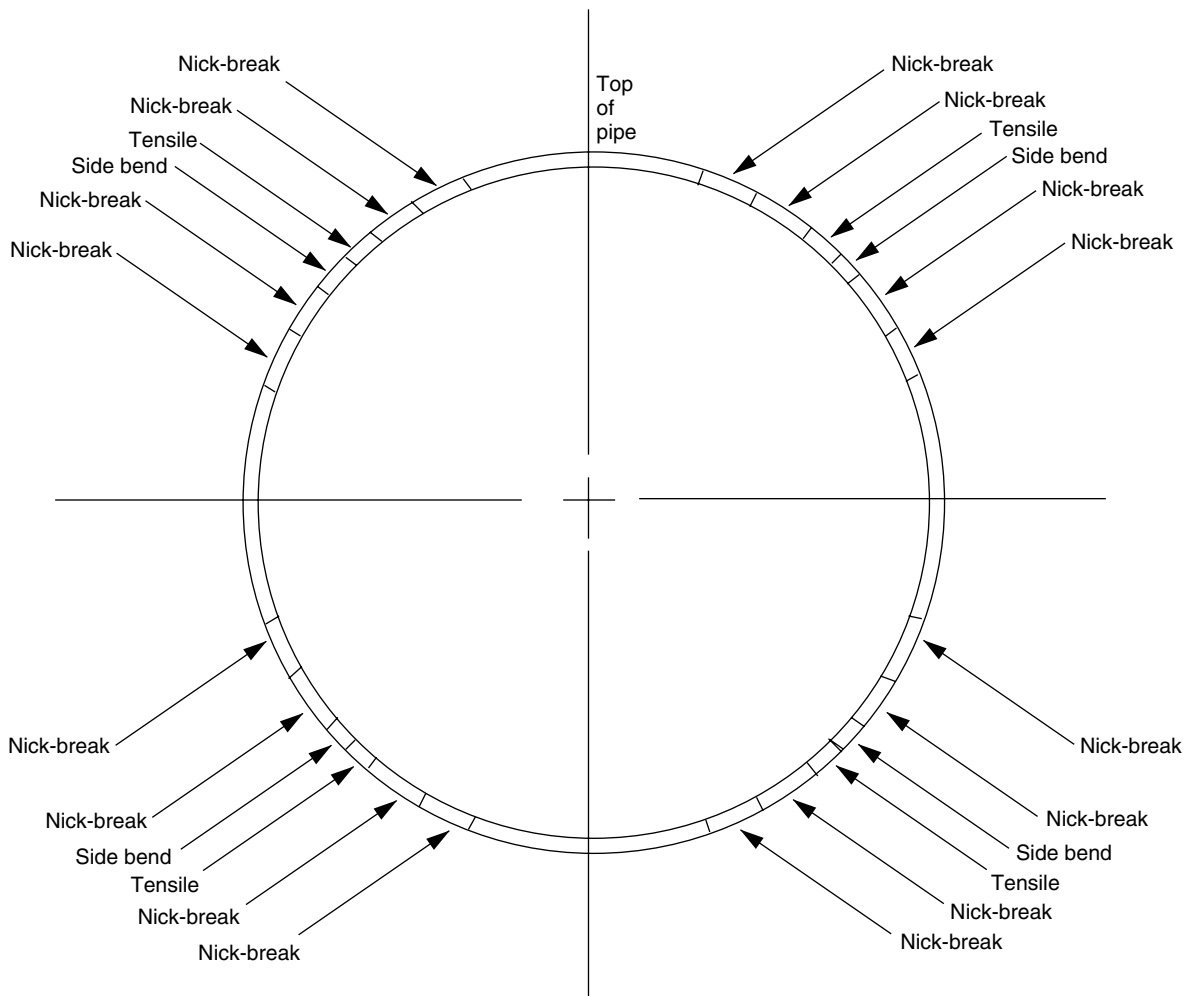

Note: All Nick-break specimens shall be in accordance with Figure 25.

Figure 22—Location of Test Butt-weld Specimens for Flash-weld Procedure Qualification Test: Outside Diameter Greater Than 18 in. (457 mm) but Less Than or Equal to 24 in. (610 mm)

13.5.2 Changes Requiring Requalification

A change in any of the factors listed in items a through k below constitutes an essential variable:

- a. Pipe material.
- b. Pipe wall thickness or outside diameter.
- c. Pipe preparation dimensions.
- d. Welding position.
- e. Requirements for pre-heat treatment.
- f. Welding voltage tolerances.
- g. Welding current tolerances.
- h. Axial speed tolerances.
- i. Time intervals in weld cycle.
- j. Upset stroke tolerances.
- k. Requirements for post-heat treatment.

13.6 QUALIFICATION OF EQUIPMENT AND OPERATORS

Each welding unit and each operator shall be qualified by producing an acceptable weld using the qualified welding procedure. The completed weld shall be tested by both radiographic and mechanical test methods, as specified in 13.2. Each operator shall have received adequate training in the operation of the equipment prior to the start of welding and shall be thoroughly familiar with the equipment they operate.

13.7 RECORDS OF QUALIFIED OPERATORS

A record shall be made of the tests required by 13.6 and of the detailed results of each test. A form similar to that shown in Figure 2 should be used. (This form should be developed to suit the needs of the company but must be sufficiently detailed to demonstrate that the qualification test meets the

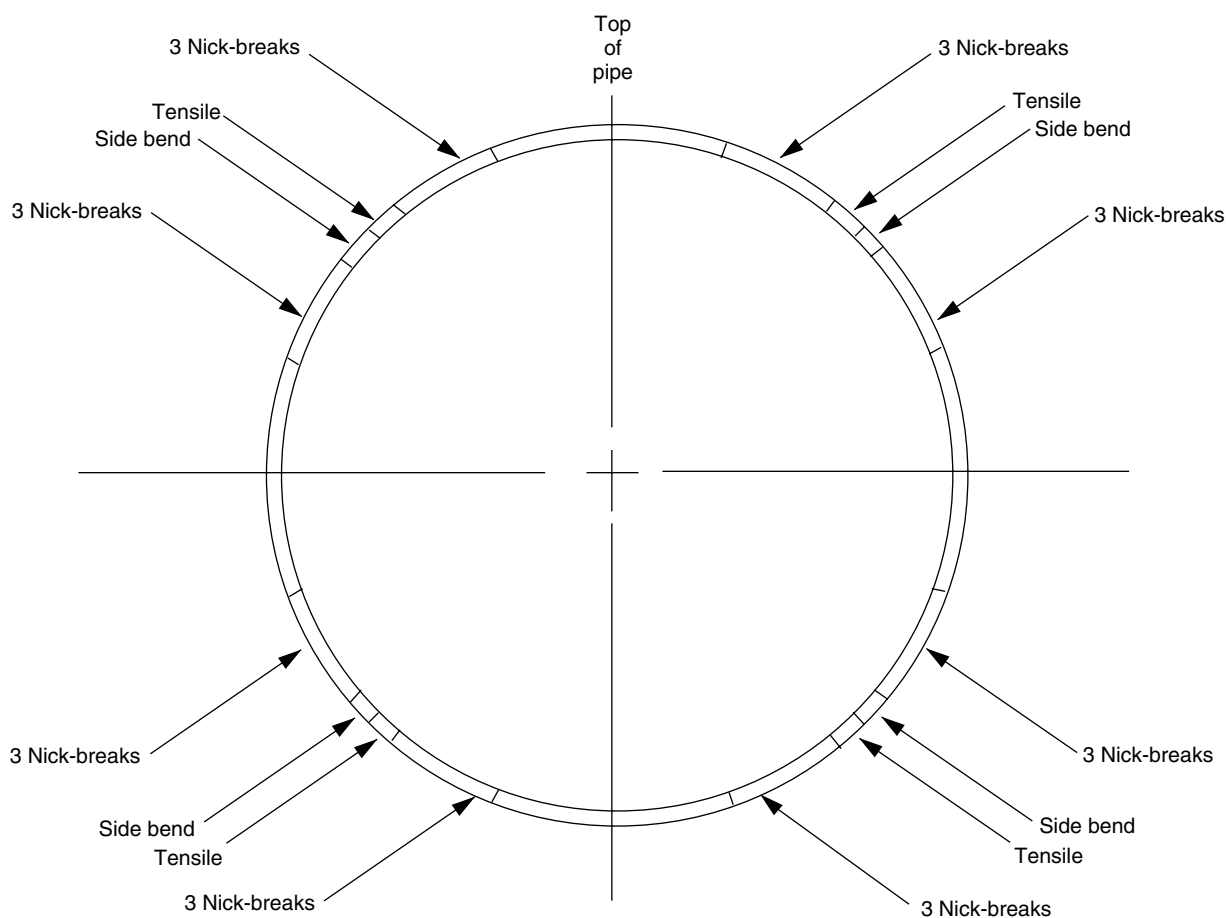

Note: All Nick-break specimens shall be in accordance with Figure 25.

Figure 23—Location of Test Butt-weld Specimens for Flash-weld Procedure Qualification Test: Outside Diameter Greater Than 24 in. (610 mm) but Less Than or Equal to 30 in. (762 mm)

requirements of this standard.) A list of qualified operators and the procedures for which they are qualified shall be maintained. An operator may be required to requalify if a question arises about their competence.

13.8 QUALITY ASSURANCE OF PRODUCTION WELDS

13.8.1 Rights of Inspection

The company shall have the right to inspect all welds by nondestructive means and by removing welds and subjecting them to metallurgical or mechanical tests, or both. The fre-

quency of such additional inspections and tests shall be as specified by the company.

13.8.2 Rejection Based on Strip Chart

During the automatic welding sequence, the operator shall monitor the electrical and mechanical procedure parameters of the welding machine on an appropriate strip-chart recorder.

If any of the welding parameters deviate beyond the tolerances specified in the procedure specification, the weld shall be unacceptable. If the strip chart is found to be unacceptable after welding has been completed, the joint shall be rejected and removed from the line.

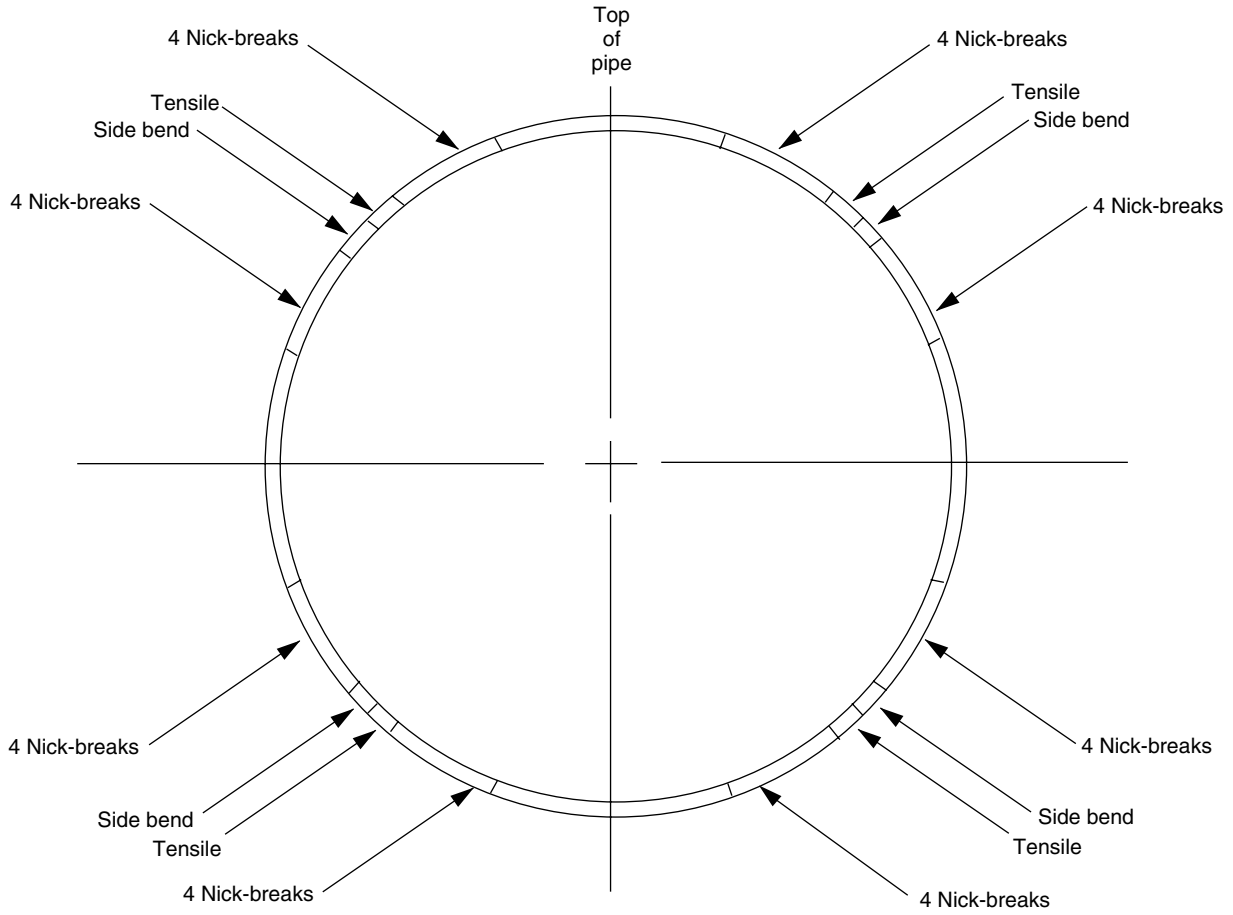

Note: All Nick-break specimens shall be in accordance with Figure 25.

Figure 24—Location of Test Butt-weld Specimens for Flash-weld Procedure Qualification Test: Outside Diameter Greater Than 30 in. (762 mm)

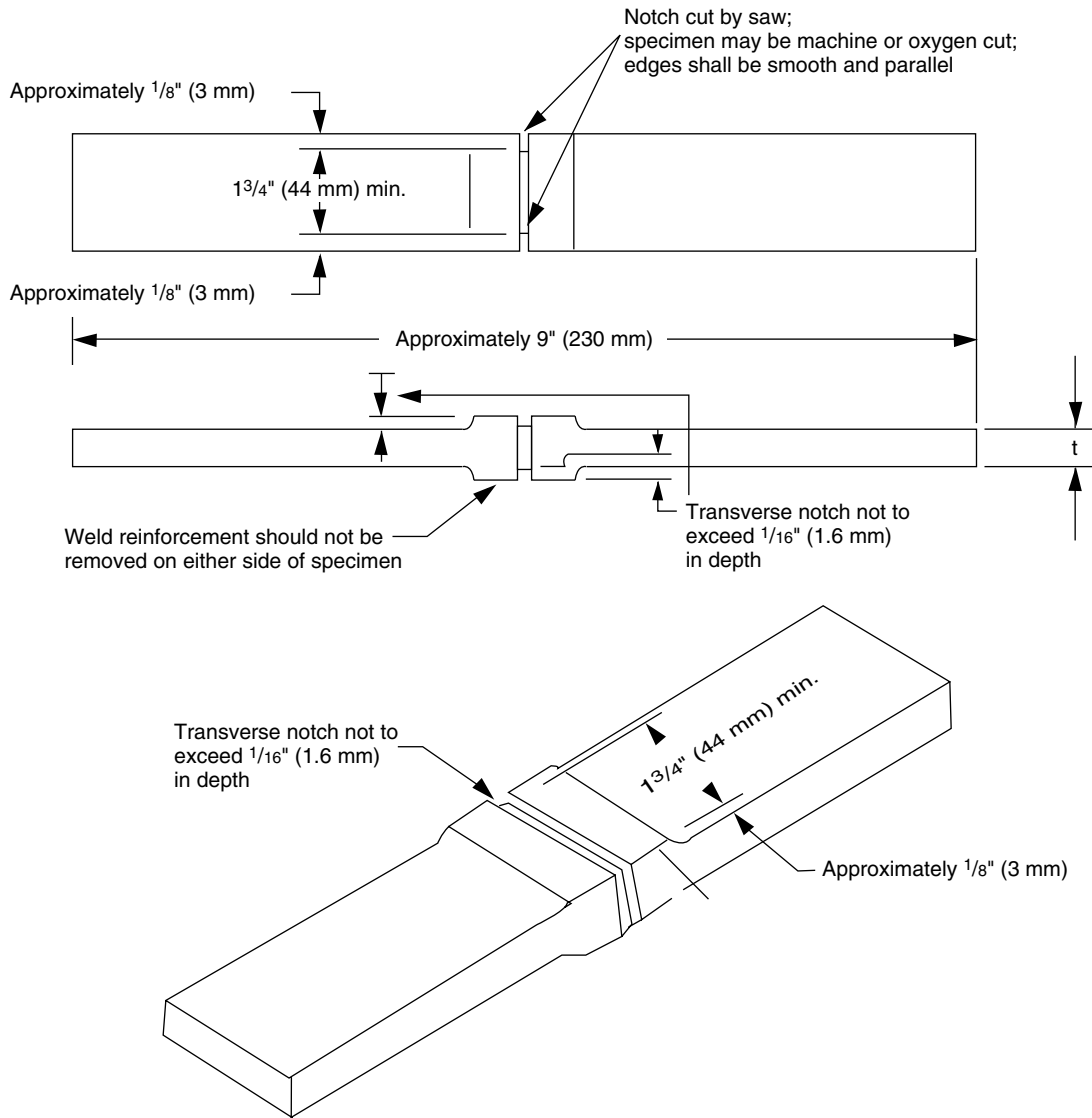

Figure 25—Two-inch Nick-break Test Specimen

13.8.3 Rejection Based on Nondestructive Testing

Each production weld shall be inspected visually and radiographically after flash removal and post-heat treatment are complete. Other nondestructive tests may also be required by the company. Each production weld shall meet the requirements of 13.9.

13.8.4 Rejection Based On Reinforcement

The inside-diameter weld reinforcement shall not be raised above the parent material by more than $1/16$ in. (2 mm). The outside diameter weld reinforcement shall not be raised above the parent material by more than $1/8$ in. (3 mm).

13.8.5 Rejection Based on Post-heat Treatment

As a minimum, each completed flash butt weld shall be heated after welding to a temperature above the Ac3 temperature, followed by either controlled cooling or still-air cooling. The heat treatment cycle shall be documented using a strip-chart recorder, and any deviation beyond the ranges specified for heating time, maximum temperature, or cooling rate shall be cause for reheat treatment.

13.9 ACCEPTANCE STANDARDS FOR NONDESTRUCTIVE TESTING

13.9.1 General

The acceptance standards given in 13.9.2 are applicable to the determination of the size and type of imperfections

located by radiography and other nondestructive test methods. They may also be applied to visual inspection.

13.9.2 Defects

ISIs shall be considered defects if any single ISI exceeds $1/8$ in. (3 mm), or the aggregate length of ISIs in any continuous 12 in. (300 mm) length of weld exceeds $1/2$ in. (13 mm). In flash butt welds, cracks, incomplete fusion, and porosity detected by nondestructive testing are considered defects.

13.10 REPAIR AND REMOVAL OF DEFECTS

13.10.1 Repairs Permitted

The following repairs are permissible:

- a. Surface defects may be removed by grinding, provided the pipe's minimum wall thickness is not violated.
- b. Defects may be removed from the weld by grinding, chipping, gouging, or a combination of these methods, followed by a weld repair in accordance with Section 10.

Repair by welding is permitted only by agreement with the company.

13.10.2 Repairs Not Permitted

Repair of porosity found in flash butt welds is not permitted; however, porosity in a repair weld deposit made with a different welding process is permitted within the limits defined in 9.3.8.2 or 9.3.8.3, whichever is applicable.

13.11 RADIOGRAPHIC PROCEDURE

Radiographic testing shall be in accordance with 11.1.

APPENDIX A—ALTERNATIVE ACCEPTANCE STANDARDS FOR GIRTH WELDS

A.1 General

The acceptance standards given in Section 9 are based on empirical criteria for workmanship and place primary importance on imperfection length. Such criteria have provided an excellent record of reliability in pipeline service for many years. The use of fracture mechanics analysis and fitness-for-purpose criteria is an alternative method for determining acceptance standards and incorporates evaluation of the significance of both imperfection height and imperfection length. The fitness-for-purpose criteria provide more generous allowable imperfection sizes, but only when additional procedure qualification tests, stress analyses, and inspections are performed. This appendix presents the minimum requirements to permit use of the alternative acceptance standards. It does not prevent the use of Section 9 for determining imperfection acceptance limits for any weld, nor does it impose any restriction on allowable strain, since this is covered by other standards and regulations. Use of this appendix for the evaluation of any or all imperfections, including circumferential cracks, is completely at the company's option.

It is usually impractical to qualify individual pipeline welds for the alternative acceptance limits after a defect under Section 9 is detected, because destructive testing is required to establish the minimum fracture toughness level for the welding procedure under consideration. Only circumferential welds between pipes of equal nominal wall thickness are covered by this appendix. Welds in pump or compressor stations are excluded, as are fittings and valves in the main line. Repair welds are also excluded. Welds subjected to applied axial strain of more than 0.5% are not covered by this appendix. The alternative acceptance standards are restricted to pipeline sections for which nondestructive inspection is performed for essentially all girth welds. The fitness-for-purpose acceptance criteria may be applied to any number of a pipeline's girth welds that are not excluded and that meet the additional requirements of this appendix.

In this appendix, the use of the phrase *imperfection acceptance limits* and other phrases containing the word *imperfection* is not intended to imply a defective condition or any lack of weld integrity. All welds contain certain features variously described as artifacts, imperfections, discontinuities, or flaws. The primary purpose of this appendix is to define, on the basis of a technical analysis, the effect of various types, sizes, and shapes of such anomalies (called *imperfections* herein) on the suitability of the whole weld for a specific service.

Note: This appendix contains only values expressed in inch-pound units; however, it is acceptable to make evaluations with all values expressed in SI units.

A.2 Additional Requirements for Stress Analysis

A.2.1 AXIAL DESIGN STRESS

To use this appendix, the company must perform a stress analysis to determine the maximum axial design stresses for the pipeline. The total axial stress acting on a imperfection also includes a residual stress from welding, which, in the case of welds that are not thermally stress relieved, may approach the yield strength of the material. The total of the applied tensile stress and the residual stress may exceed the yield strength and is more conveniently treated as percent strain. A yield-strength residual strain of 0.2% was assumed in developing the acceptance criteria given in this appendix. The maximum applied axial strain to be used for a particular pipeline shall be determined by stress analysis and documented by the company.

A.2.2 CYCLIC STRESS

A.2.2.1 Analysis

The cyclic stress analysis shall include the determination of predicted fatigue spectrum to which the pipeline will be exposed over its design life. This spectrum shall include but is not limited to stresses imposed by hydrostatic testing, installation stresses, and where applicable, thermal, seismic, and subsidence stresses. The spectrum should consist of several cyclic axial stress levels and the number of cycles applicable to each. If the stress levels vary from cycle to cycle, a suitable counting method, such as the rainflow method, should be used to determine cyclic stress levels and cycle count.

Note: For an example of the use of the rainflow method, see N. E. Dowling, "Fatigue Failure Predictions for Complicated Stress-Strain Histories," *Journal of Materials*, March 1972, Volume 7, Number 1, pp. 71 – 87.

The spectrum severity, S^* , should be calculated from the following formula:

$$S^* = N_1(\Delta\sigma_1)^3 + N_2(\Delta\sigma_2)^3 + N_k(\Delta\sigma_k)^3$$

where

S^* = spectrum severity,

N_i = number of cycles at the i th cyclic stress level,

$\Delta\sigma_i$ = cyclic stress range, in kips per square in.,

Subscript k = number of cyclic stress levels,

Subscript i = range of increments from 1 to k .

The allowable imperfection sizes shown in Figure A-5 apply when S^* is less than or equal to 4×10^7 . When S^* is greater than 4×10^7 , this appendix shall not be used.

A.2.2.2 Environmental Effects on Fatigue

The enlargement of weld imperfections due to fatigue is a function of stress intensity, cycles of loading, imperfection size, and the environment at the crack tip. In the absence of contaminating elements, oil and hydrocarbons are considered no worse than air. Water, brine, and aqueous solutions that contain CO_2 or H_2S may, however, increase the growth rate. It is normal for minor amounts of these components to be present in nominally noncorrosive pipelines. When the concentration of either CO_2 or H_2S exceeds typical historical levels experienced in noncorrosive pipelines, this appendix shall not be used, unless evidence exists that the proposed levels do not result in acceleration of fatigue crack growth. The effects of environment on fatigue crack growth external to the pipe at girth welds are normally mitigated by external coating and cathodic protection and do not limit the use of this appendix.

A.2.3 SUSTAINED-LOAD CRACKING

Certain environments may enhance imperfection growth in service at sustained load or induce brittleness in the material surrounding the imperfection to the point that an otherwise dormant imperfection becomes critical. These environments typically contain H_2S but may contain strong hydroxides, nitrates, or carbonates. When these materials are present inside the pipe, a minimum threshold stress shall be established, and this appendix shall not be used if the calculated stress exceeds the threshold value. With respect to H_2S service, the definition of such service shall be that given in NACE MR0175. Although external exposure to carbonates and nitrates in the soil has been shown to produce stress corrosion cracking in a small number of cases, the cracking is normally axial and is associated with circumferential stress rather than axial stress. No pipeline failures are known to have originated from stress corrosion cracking in a girth weld.

The frequency and severity of stress corrosion cracking can be mitigated by the use of proper coating and proper cathodic protection. The use of this appendix is not precluded when

direct exposure to the aggressive environment is prevented by a coating designed to resist the environment.

A.2.4 DYNAMIC LOADING

The stress analysis shall include consideration of potential dynamic loading on girth welds, such as loads from closure of check valves. This appendix does not apply to welds strained at a rate greater than 10^{-3} seconds⁻¹ (a stressing rate of 30 kips per sq. in. per second for steel).

A.3 Welding Procedure

A.3.1 GENERAL

The controls of the variables necessary to ensure an acceptable level of fracture toughness in a welding procedure are more stringent than those controlling welding procedures without minimum toughness requirements. Qualification of welding procedures to be used with this appendix shall be in accordance with Sections 5 or 12 of this standard, with the following exceptions and additional requirements:

- Crack-tip-opening displacement (CTOD) testing shall be performed in accordance with A.3.3.
- The tensile-strength specimen used to qualify the welding procedure shall not fail in the weld.

Any change in the essential variables specified below shall require re-qualification of the welding procedure:

- A change in the welding process or method of application.
- A change in the grade or manufacturing process of the pipe material or a basic change in the chemical composition or processing.
- A major change in joint design (e.g., from U groove to V groove). Minor changes in the angle of bevel or the land of the welding groove are not essential variables.
- A change in position from roll to fixed, or vice versa.
- A change in the nominal qualified wall thickness of more than ± 0.125 in.
- A change in the size or type of filler metal, including a change of manufacturer, even within an AWS classification.
- An increase in the time between completion of the root bead and the start of the second bead.
- A change in direction (e.g., from vertical downhill to vertical uphill, or vice versa).
- A change from one shielding gas to another or from one mixture of gases to a different mixture.
- A change in the nominal qualified flow rate of shielding gas of more than $\pm 10\%$.
- A change in the shielding flux, including a change in manufacturer within an AWS classification.
- A change in the nominal heat input of any bead of more than 10%. The heat input may be calculated from the following equation:

$$J = 60VA/S$$

where

J = heat input (in joules per in.),

V = voltage,

A = amperage,

S = speed (in in. per minute).

- m. A change in the type of current (AC or DC) or polarity.
- n. A change in the requirements for pre-heat treatment.
- o. A change in the requirements for post-heat treatment or addition or deletion of a requirement for post-heat treatment.
- p. A change in the nominal pipe outside diameter more than $-0.25D$ or $+0.5D$, where D is the pipe outside diameter of procedure qualification welds.

A.3.2 FRACTURE TOUGHNESS TESTING

To use the alternative girth-weld acceptance criteria, the fracture toughness of the weld shall be determined by testing. The applicable fracture-toughness test method is the CTOD

method. For the purpose of this appendix, the minimum fracture toughness can be 0.005 in. or 0.010 in. or a value between these two values.

CTOD tests shall be performed in accordance with BS 7448: Part 2, as supplemented by this appendix. The preferred test piece ($B \times 2B$) shall be used. As shown in Figure A-1, the specimen should be oriented so that its length is parallel to the pipe axis and its width is in the circumferential direction; thus, the crack-tip line is oriented in the through-thickness direction. The specimen thickness (see Figure A-2) should be equal to the pipe thickness less the minimum amount of milling and grinding necessary to produce a specimen with the prescribed rectangular cross section and surface finish from a curved pipe segment. (The weld reinforcement shall be removed.) The specimen should be etched after initial preparation to reveal the weld deposit and the geometry of the heat-affected zone. For weld-metal tests, the notch and fatigue crack tip should be located completely in weld metal; furthermore, for weld preparations typical of pipeline girth welds, the notch and fatigue crack tip should be at the center of the weld (see Figure A-3).

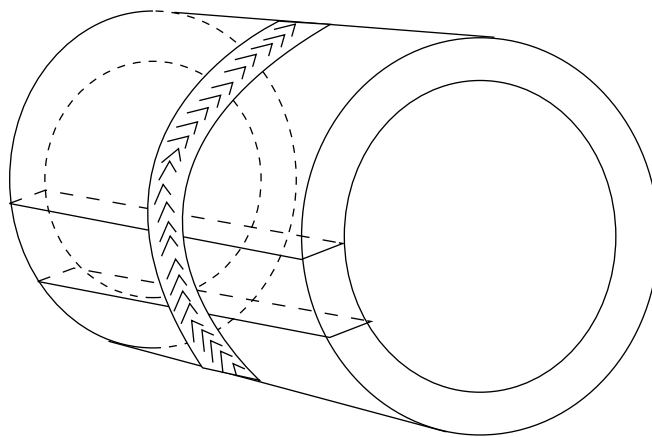

Figure A-1—Location of CTOD Test Specimens

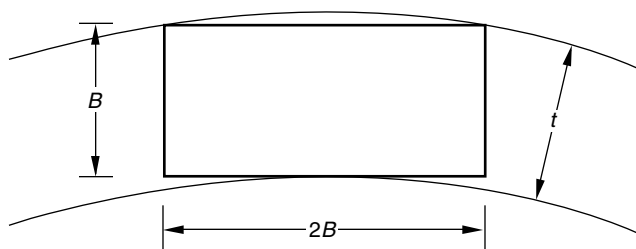

Figure A-2—Machining Objective for CTOD Test Specimen with Respect to Pipe Wall

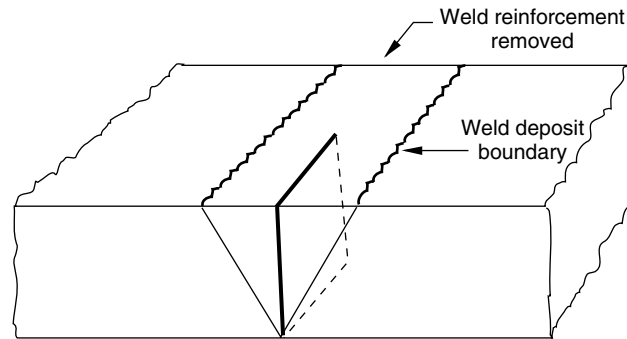

Figure A-3—Location of Notch for Weld-metal Specimen

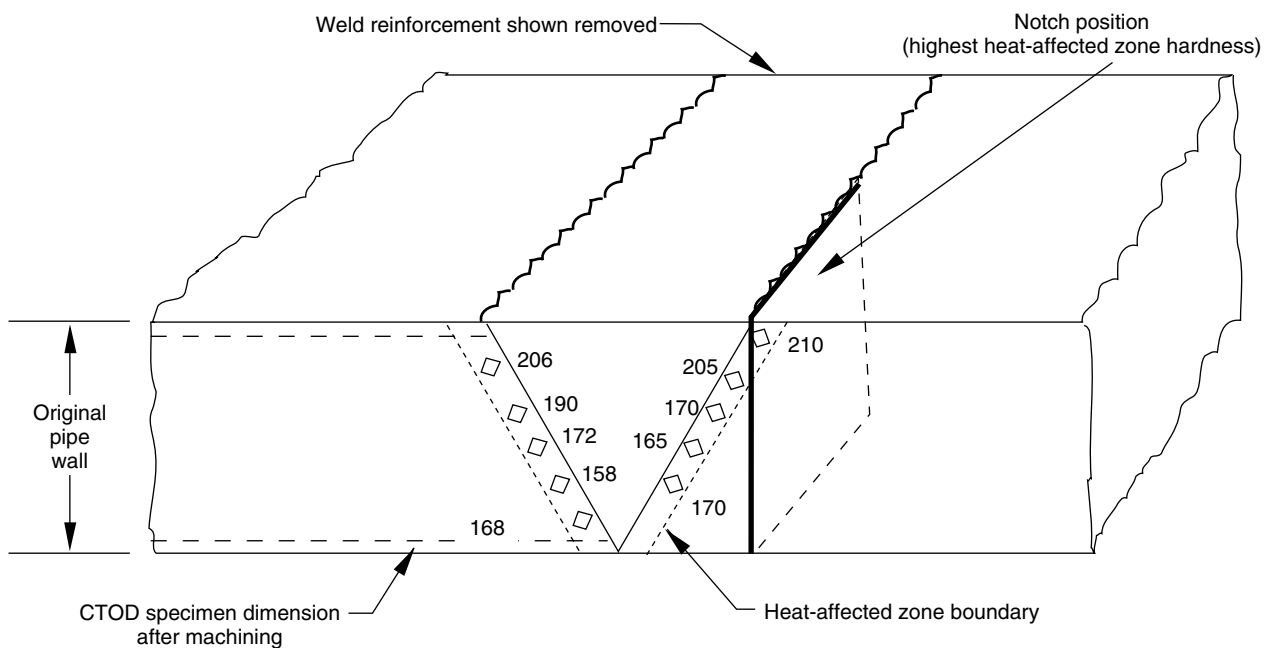
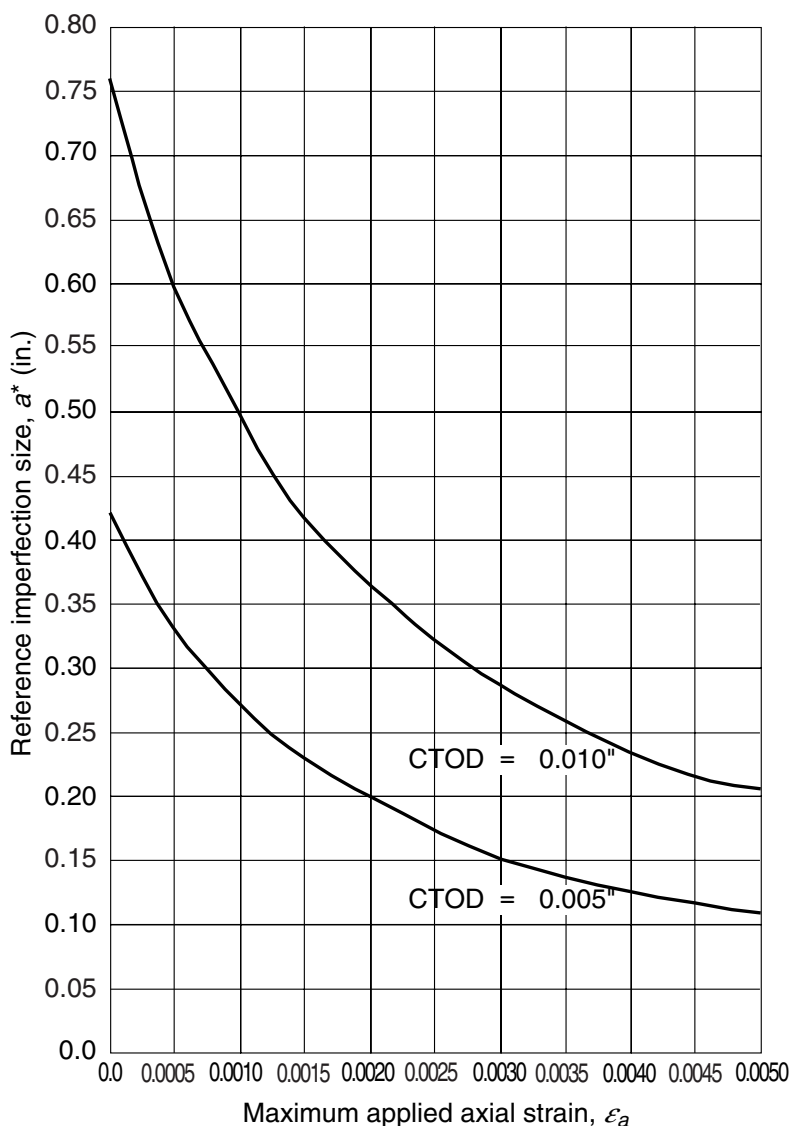

Figure A-4—Location of Notch for Heat-affected Zone Specimen

For each heat-affected zone test, a microhardness survey should be conducted on the specimen itself or on a weld cross-section coupon taken from the immediate vicinity of the specimen (see Figure A-4). The objective of this survey is to locate the area of greatest hardness (discounting isolated anomalous readings). This area will normally be found to be in the heat-affected zone, immediately adjacent to the fusion line for the last welding pass. The notch and fatigue crack tip should be placed so that they cross the area of greatest hardness, disregarding the fact that most of the resulting fatigue crack front will usually not be in the heat-affected zone.

After testing, particular attention should be given to the validity criteria of 12.4.1 of BS 7448: Part 2; these criteria deal with the geometry of the fatigue crack front. For this appendix, the appropriate value of CTOD shall be δ_c , δ_w , or δ_m . (These are mutually-exclusive terms defined in BS 7448: Part 2 that describe the three possible and mutually-exclusive

outcomes of the test. The value of δ_i [CTOD at initiation of stable crack growth] has no significance with regard to this appendix and need not be measured.) When δ_m applies, care should be taken to measure from the point of first attainment of maximum load. “Pop in cracking” must be considered the controlling event if any load drop occurs. The test report shall include all items specified in Section 13 of BS 7448: Part 2. Particular attention should be given to reporting the position of the test specimen in the qualification weld and to distinguishing whether the reported CTOD value represents δ_c , δ_w , or δ_m . The test report shall also include a legible copy of the load-displacement record and a record of the appearance of the fracture surfaces; the latter requirement can be satisfied by a clear photograph of one or both fracture surfaces or by retaining one or both fracture surfaces (properly preserved and identified) for direct observation.



Notes:

1. In addition to all other limitations, the height shall not exceed one-half the wall thickness.
2. For interacting imperfections, the length and height of the imperfection shall be determined by Figure A-6.
3. For surface imperfections, the allowable imperfection height, a^* , is subject to the restriction of Note 1.
4. For buried imperfections, the allowable imperfection height, $2a^*$, is subject to the restriction of Note 1. The status of a buried imperfection is determined by Figure A-6, Case 4.
5. Limits on imperfection length are given in Table A-3.
6. The maximum allowable applied axial strain may be limited by other standards and regulations.
7. A residual strain of 0.002 in. per inch is included in each of the curves.
8. The CTOD curve equation is:

$$a \text{ (in.)} = \{[\delta_c/2\pi(\epsilon_a - 0.25\epsilon_0)]^{-1/2} + 0.1667\}^{-2}$$

$$\epsilon_a = \epsilon \text{ applied} + \epsilon \text{ residual} = \epsilon \text{ applied} + 0.002 \text{ in.}$$

$$\epsilon_0 = 0.002 \text{ in.}$$

$$\delta_c = \text{CTOD value of 0.005 in. or 0.010 in. or a value between these two values based on minimum value obtained during testing}$$

Figure A-5—Alternative Acceptance Criteria for Circumferential Planar Imperfections

A.3.3 CTOD TESTING FOR PROCEDURE QUALIFICATION

CTOD tests for procedure qualification shall be performed as described below and shall conform to the testing details described in A.3.2. For each welding procedure, both the weld metal and the heat-affected zone shall be tested, and each must satisfy the fracture-toughness requirement before the fitness-for-purpose criteria can be employed. Each test (of weld metal or heat-affected zone) shall consist of at least three valid specimen tests performed at or below the lowest anticipated service temperature.

The three specimens shall consist of one each from the nominal twelve, three, and six o'clock positions on the test weld and should be permanently marked to identify the original position. If only one of the three valid specimen tests fails the fracture-toughness requirement, a second set of three tests may be performed; five of the six resulting valid specimen tests must meet the fracture-toughness requirement for the entire test (of weld metal or heat-affected zone) to be successful.

The failure of a single specimen to meet the required CTOD necessitates a second set of tests for weld metal or heat-affected zone only; the test of the other portion of the weldment need not be repeated if it was originally successful. The weld metal and heat-affected zone tests must both successfully meet the fracture-toughness requirement for the procedure to be qualified for use with the alternative acceptance criteria.

Specimens that are incorrectly machined, that fail to meet the criteria for curvature of the fatigue crack front, or that upon fracture exhibit substantial weld imperfections adjacent to the crack front are defined as invalid specimens. Invalid specimens shall be discarded and replaced by new specimens on a one-for-one basis.

A.4 Qualification of Welders

Welders shall be qualified in accordance with Section 6. For mechanized welding, the welding unit and each operator shall be qualified in accordance with 12.6.

A.5 Inspection and Acceptable Limits

A.5.1 PLANAR IMPERFECTIONS

The length and height of an imperfection, and its depth below the surface, must be established by appropriate nondestructive inspection techniques or otherwise justified before a decision to accept or reject can be made. Conventional radiography, as described in 11.1, is adequate for measuring imperfection length but is insufficient for determining height, particularly for planar imperfections such as cracks, lack of fusion, undercutting, and some types of lack of penetration. The use of ultrasonic techniques, radiographic techniques that employ densitometers or comparative visual reference standards, acoustic imaging, inherent imperfection-size limitations due to weld-pass geometry, or any other technique for determining imperfection height is acceptable, provided the technique's accuracy has been established and any potential inaccuracy is included in the measurement; i.e., the determination of imperfection height shall be conservative. The use of conventional radiography (see 11.1) to identify imperfections that require height measurement by other means is acceptable. The acceptance limits for circumferential planar imperfections are shown in Figure A-5. Planar imperfections that are transverse to the girth weld, such as transverse cracks, shall be repaired or removed.

A.5.2 VOLUMETRIC IMPERFECTIONS

Buried volumetric (three-dimensional) imperfections, such as slag or porosity, contained in material with high fracture toughness are much less likely to cause failure than planar imperfections and may be evaluated either by the same method used for planar imperfections or by the simplified method shown in Table A-1. Surface-connected volumetric imperfections shall be treated as planar imperfections and evaluated according to the criteria of Figure A-5.

Table A-1—Acceptance Limits for Buried Volumetric Imperfections

Imperfection type	Height or Width	Length
Porosity ^a	Lesser of $t/4$ or 0.25 in.	Lesser of $t/4$ or 0.25 in.
Slag	Lesser of $t/4$ or 0.25 in.	$4t$
Unrepaired burn-through	$t/4$	$2t$

Note: The simplified limits given in this table may be applied for minimum CTOD levels of either 0.005 in. or 0.010 in., but only within the scope of this appendix. Alternatively, the company may elect to treat these imperfections as planar imperfections and employ Figure A-5. This table shall not be used with the surface-connected volumetric imperfections (Figure A-6, Case 1) and surface interacting imperfections (Figure A-6, Cases 3 and 4), which shall be evaluated by Figure A-5.

^aLimited to 3% of the projected area.

A.5.3 ARC BURNS

Arc burns may occur on the internal or external surface of the pipe as a result of inadvertent arc strikes or improper grounding. They generally appear as a pit or cavity visible to the eye or as a dense area on the radiograph. The cavity may be surrounded by a hard heat-affected zone that may be of lower toughness than the base material or the weld deposit.

The acceptance limits for unrepaired arc burns are given in Table A-2 and are based on the premise that the heat-affected zone has zero toughness but that any planar imperfection originating within the heat-affected zone is blunted at the edge of the zone. Substantial data indicate that the total depth of the arc burn, including the heat-affected zone, is less than half the width of the burn.

Arc burns that contain cracks visible to the eye or on conventional radiographs are not covered by this appendix and shall be repaired or removed.

A.5.4 IMPERFECTION INTERACTION

If adjacent imperfections are close enough, they may behave as single larger imperfections. Figure A-6 shall be used to determine whether interaction exists. If it does, the effective imperfection sizes shown in Figure A-6 shall be computed and the acceptability of the effective imperfection shall be evaluated by the applicable acceptance criteria. If a repair is indicated, any interacting imperfections shall be repaired in accordance with A.8.

A.6 Record

A company representative shall record on a suitable form the type, location, and dimensions of all imperfections accepted in accordance with this appendix. This record shall be filed with the radiographs or other records of nondestructive tests of the pipeline.

A.7 Example

A.7.1 DESCRIPTION

Consider a pipeline project that uses 36 in. outside diameter, 0.812 in. wall thickness, API 5L X 65 pipe. The field pipe-to-pipe girth welds are to be made by mechanized gas metal-arc welding and are to receive essentially 100% nondestructive examination. The welding procedure has been qualified to a CTOD value of 0.010 in. in accordance with this appendix. The stress analysis has resulted in an estimate of maximum applied axial strain of 0.002 in. per in. None of the restrictions of A.2.2 through A.2.4 have been violated. The company has arranged for use of a nondestructive testing technique capable of determining imperfection height and has sufficient documentation to demonstrate that imperfections will be no more than 0.050 in. larger than indicated by the

inspection report. The company has chosen to apply this inspection technique only to imperfections that fail the acceptance standards of Section 9 and to use conventional radiography to determine conformance with that section.

A.7.2 CALCULATIONS AND ACCEPTANCE CRITERIA

The steps for calculating the allowable dimensions of planar imperfections are shown in A.7.2.1 through A.7.2.9.

A.7.2.1 Step 1

The following pertinent information is collected:

- The pipe outside diameter, D , is 36 in.
- The pipe wall thickness, t , is 0.812 in.
- The qualified minimum CTOD is 0.010 in.
- The maximum applied axial strain, ϵ_a , is 0.002 in. per in.
- The allowance for inspection error is 0.050 in.

A.7.2.2 Step 2

Figure A-5 is consulted to determine a^* . For $\epsilon_a = 0.002$ in. and CTOD = 0.010 in., $a^* = 0.36$ in.

A.7.2.3 Step 3

The tentative allowable surface imperfection height (see Figure A-5, Note 3) and the tentative allowable buried imperfection height (see Figure A-5, Note 4) are determined. For surface imperfections,

$$a_{\text{all},s,t} = a^* = 0.36 \text{ in.}$$

For buried imperfections:

$$2a_{\text{all},b,t} = 2a^* = 0.72 \text{ in.}$$

A.7.2.4 Step 4

The tentative allowable imperfection sizes are compared with Figure A-5, Note 1, to determine the maximum allowable imperfection sizes:

$$a_{\text{max}} = 0.5t = 0.406 \text{ in.}$$

For surface imperfections:

$$a_{\text{all},s,t} \leq a_{\text{max}}$$

Therefore:

$$a_{\text{all},s} = a_{\text{all},s,t} = 0.360 \text{ in.}$$

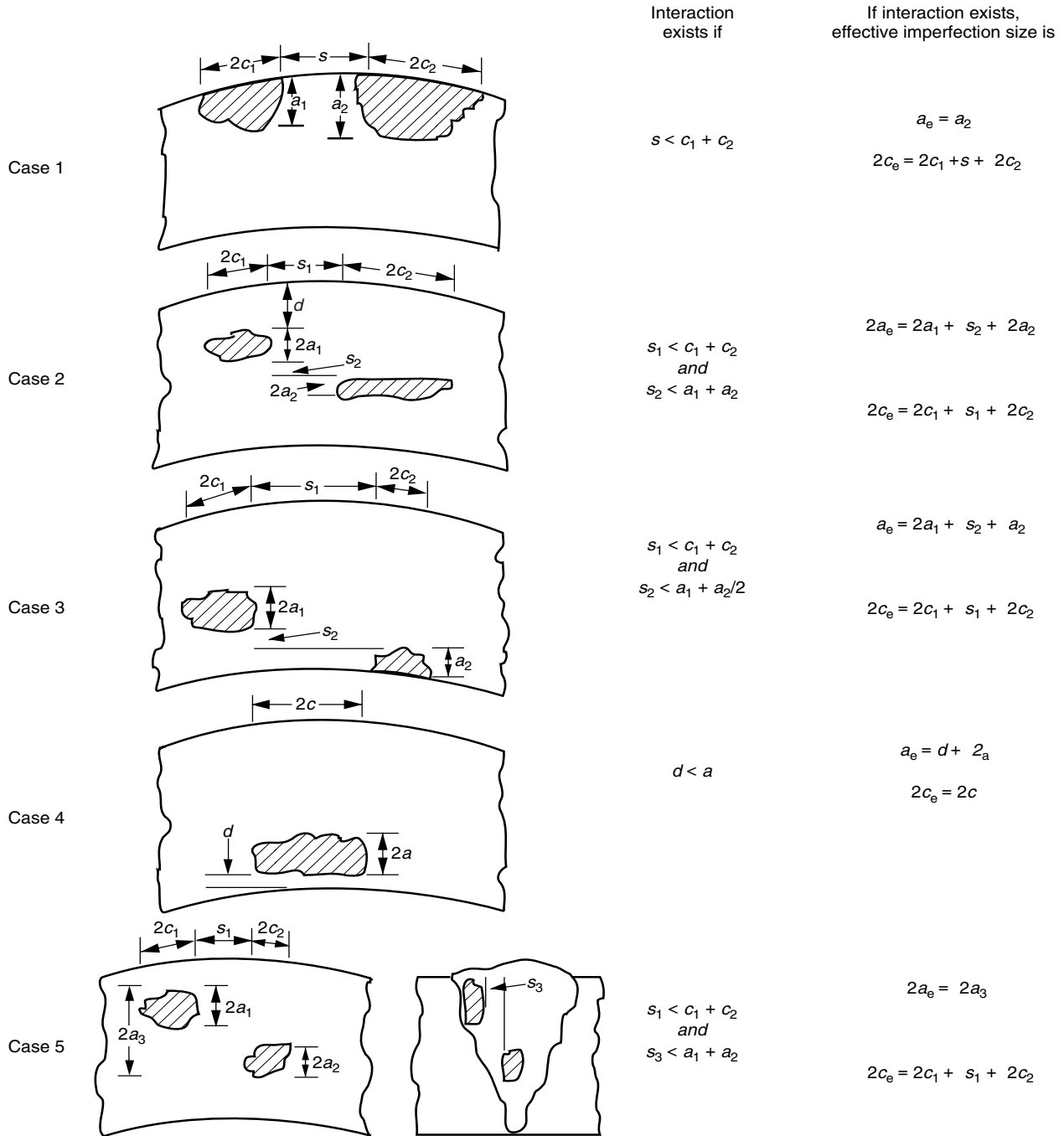

Figure A-6—Criteria for Evaluation of Imperfection Interaction

Table A-2—Acceptance Limits for Unrepaired Arc Burns

Measured Dimension	Acceptance Limit
Width	Lesser of t or $5/16$ in.
Length (any direction)	Lesser of t or $5/16$ in.
Depth (to bottom of crater)	$1/16$ in.

Note: The limits given in this table apply for minimum CTOD levels of either 0.005 in. or 0.010 in., but only within the scope of this appendix.

For buried imperfections:

$$2a_{\text{all},b,t} > a_{\text{max}}$$

Therefore:

$$2a_{\text{all},b} = a_{\text{max}} = 0.406 \text{ in.}$$

A.7.2.5 Step 5

In accordance with Figure A-5, Note 5, Table A-3 is consulted to determine the limits on allowable imperfection length. The relevant imperfection dimensions are computed as follows: For $a/t = 0.25$:

$$a_1 = 0.25t = 0.203 \text{ in.}$$

$$2c_1 = 0.4D = 14.4 \text{ in.}$$

$$2c_2 = 4t = 3.25 \text{ in.}$$

A.7.2.6 Step 6

The D/t ratio is computed, and compliance with Table A-3, Note 2, is checked as follows:

$$D/t = 36/0.812 = 44.3 > 17$$

Therefore, $2c_2$ is unchanged.

A.7.2.7 Step 7

The height limit for shallow imperfections, a_1 , is compared with the maximum allowable imperfection sizes to determine whether imperfections greater than 25% of the wall thickness are permissible. For surface imperfections,

$$a_1 < a_{\text{all},s}$$

$$2c_{2,s} = 2c_2 = 3.25 \text{ in.}$$

For buried imperfections:

$$a_1 < 2a_{\text{all},b}$$

$$2c_{2,b} = 2c_2 = 3.25 \text{ in.}$$

Note: If the allowable size of a surface or buried imperfection were less than a_1 , the respective value of $2c_2$ would be set equal to zero and the respective value of a_1 would be reduced to the respective value of a_{all} determined in A.7.2.4.

Table A-3—Imperfection Length Limits

Ratio of Height to Wall Thickness	Allowable Imperfection Length $2c$
$0 < a/t < 0.25$	$0.4D$
$0.25 < a/t < 0.50$	$4t$ (see Note 2)
$0.50 < a/t$	0

Notes:

1. The limits given in this table apply for minimum CTOD levels of either 0.005 in. or 0.010 in., but only within the scope of this appendix.

2. This value is applicable when D/t is greater than 17; Figure A-7 is applicable when D/t is less than or equal to 17.

A.7.2.8 Step 8

A table of allowable imperfection dimensions is constructed in accordance with Table A-3. Table A-4 is an example of such a table, using the allowable dimensions and notation of this example.

A.7.2.9 Step 9

The acceptable dimensions for planar imperfection are determined from the allowable dimensions by subtracting the allowance for inspection error from each depth or height value:

$$a_{\text{acc}} = a_{\text{all}} - (\text{allowance for inspection})$$

Table A-5 gives the acceptable dimensions for planar imperfections for this example.

A.7.3 EVALUATION OF IMPERFECTIONS

Table A-1 gives the acceptance limits for porosity slag, and unrepaired burn-through. As the note to the table indicates, the company could elect to treat these as planar imperfections and use the same acceptance criteria. In this example, the company chooses not to do so but to use sizes determined from Table A-1. The resulting acceptance criteria are given in Table A-6. The inspection accuracy factor is not included in this case because these allowable imperfection sizes are already smaller than the allowable fracture-critical imperfection sizes for planar imperfections.

Table A-6 also includes acceptance criteria for arc burns, determined from Table A-2.

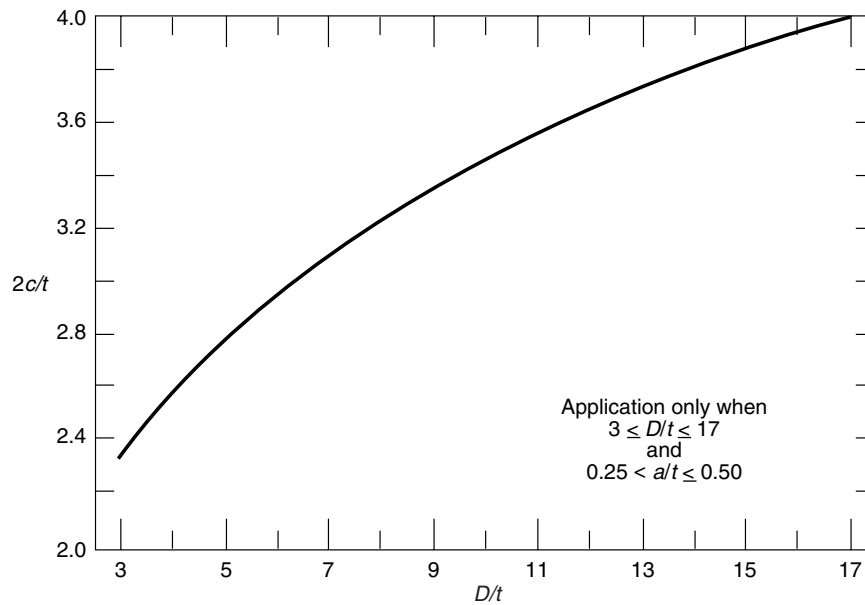

Note: This figure is applicable only when $3 \leq D/t \leq 17$ and $0.25 < a/t \leq 0.50$.

Figure A-7—Length Limit for Deep Imperfections in Heavy-Wall Pipe

Table A-4—Allowable Imperfection Dimensions for Example

Surface Imperfections		Buried Imperfections	
Height	Allowable Length	Height	Allowable Length
$0 - a_{1,s}$	$2c_1$	$0 - a_{1,b}$	$2c_1$
$a_{1,s} - a_{all,s}$	$2c_{2,s}$	$a_{1,b} - 2a_{all,b}$	$2c_{2,b}$
0 – 0.203 in.	14.40 in.	0 – 0.203 in.	14.40 in.
0.204 – 0.360 in.	3.25 in.	0.204 – 0.406 in.	3.25 in.

Table A-5—Acceptable Planar Imperfection Dimensions for Example

Surface Imperfections		Buried Imperfections	
Measured Height (in.)	Acceptable Length (in.)	Measured Height (in.)	Acceptable Length (in.)
0 – 0.153	14.40	0 – 0.153	14.40
0.154 – 0.310	3.25	0.154 – 0.356	3.25
> 0.310	0.00	> 0.356	0.00

The inspector takes copies of Table A-6 and Figure A-6 to the job site and then performs the following steps for each imperfection located on the radiograph:

- The inspector determines the imperfection type and length from the radiograph.
- The inspector compares the type and length with the acceptability criteria of Section 9. If the imperfections are acceptable, repair or removal is not required.
- If the imperfections do not meet the acceptability criteria of Section 9, the inspector determines the imperfection height (and for buried imperfections, the proximity to the surface), using the auxiliary inspection technique. (If the auxiliary inspection technique also measures imperfection length, the

company may elect to improve the estimate of imperfection length at this time.)

d. The inspector compares the imperfections with Figure A-6 to determine whether interactions exist and whether nominally buried imperfections should be treated as buried or surface imperfections. If interactions with other imperfections or free surfaces exist, the inspector computes new effective imperfection sizes as shown in Figure A-6.

e. The inspector compares the imperfection dimensions with Table A-6 to determine final acceptability. If the imperfections are acceptable, no repair or cutout is required, but A.6 requires that the imperfection type, location, and dimensions be recorded and filed. If the imperfections are not acceptable, repair or removal is necessary.

Table A-6—Example Alternative Acceptance Criteria

Imperfection Type	Height Range (in.)	Acceptable Length (in.)
Planar surface imperfections	0 – 0.153	14.400
	0.154 – 0.310	3.250
Planar buried imperfections	0 – 0.153	14.400
	0.154 – 0.356	3.250
Porosity	0.203 ^a	0.203 ^a
Slag	0.203 ^b	3.250
Unrepaired burn-through	0.203 ^b	1.620
Arc burns	1/16 ^b	5/16 ^c

^aAcceptable size for any dimension.

^bAcceptable height.

^cAcceptable width and length.

A.8 Repairs

Any imperfections that are not acceptable under the provisions of this appendix shall be repaired or removed in accordance with Sections 9 and 10.

A.9 Nomenclature

a = maximum height of a surface imperfection, or one-half the height of a buried imperfection measured in a radial direction (see Figure A-8).

a^* = reference imperfection size (see Figure A-5).

a_{acc} = acceptable size of planar imperfection = a_{all} – (allowance for inspection error).

a_{all} = allowable imperfection size.

a_{max} = maximum allowable imperfection size.

a_e = effective imperfection size (see Figure A-6).

a_b = size of buried imperfection.

a_s = size of surface imperfection.

a_t = tentative imperfection size.

a_1 = height limit for shallow imperfection.

B = thickness of CTOD specimen.

$2c_1$ = maximum length of shallow imperfection.

$2c_2$ = maximum length of deep imperfection.

D = outside diameter of pipe.

d = depth of a buried imperfection beneath the nearest free surface (see Figures A-6 and A-8).

J = heat input.

S^* = severity of fatigue spectrum.

t = nominal pipe wall thickness.

δ = Crack-tip opening displacement (CTOD), in inches.

δ_c = CTOD at either unstable fracture or pop in without evidence of slow crack growth.

δ_u = CTOD at either unstable fracture or pop in with evidence of slow crack growth.

δ_m = CTOD at first attainment of maximum load.

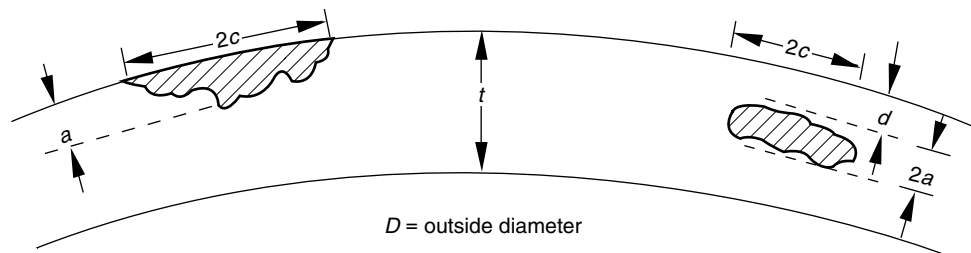

Figure A-8—Nomenclature for Dimensions of Surface and Buried Imperfections

APPENDIX B—IN-SERVICE WELDING

B.1 General

This appendix covers recommended welding practices for making repairs to or installing appurtenances on pipelines and piping systems that are in service. For the purposes of this appendix, in-service pipelines and piping systems are defined as those that contain crude petroleum, petroleum products, or fuel gases that may be pressurized and/or flowing. This appendix does not cover pipelines and piping systems that have been fully isolated and decommissioned, or have not been commissioned.

There are two primary concerns with welding onto in-service pipelines. The first concern is to avoid “burning through,” where the welding arc causes the pipe wall to be breached. The second concern is for hydrogen cracking, since welds made in-service cool at an accelerated rate as the result of the flowing contents’ ability to remove heat from the pipe wall.

Burning through is unlikely if the wall thickness is 0.250 in. (6.4 mm) or greater, provided that low-hydrogen electrodes (EXX18 type) and normal welding practices are used. Welding onto thinner-wall in-service pipelines is possible and considered routine by many companies; however, special precautions, such as the use of a procedure that limits heat input, are often specified.

For hydrogen cracking to occur, three conditions must be satisfied simultaneously. These conditions are: hydrogen in the weld, the development of a crack-susceptible weld microstructure, and tensile stress acting on the weld. To prevent hydrogen cracking, at least one of the three conditions necessary for its occurrence must be minimized or eliminated. For welds made onto in-service pipelines, success has been achieved using low-hydrogen electrodes or a low-hydrogen process and, since low hydrogen levels cannot always be guaranteed, using procedures that minimize the formation of crack-susceptible microstructures. The most common procedures use a sufficiently high heat input level to overcome the effect of the flowing contents. Several heat input prediction methods have been developed, including thermal analysis computer models.⁷ While these or other proven methods are useful in predicting the heat input required for a given in-service welding application, they are not a substitute for procedure qualification (see B.2). Preheating, where practicable, and/or the use of a temper-bead deposition sequence, can also

⁷“Development of Simplified Weld Cooling Rate Models for In-Service Gas Pipelines”, PRCI Catalog No. L51660 or “Thermal Analysis Model for Hot-Tap Welding Version 4.2,” PRCI Catalog No. L51837.

reduce the risk of hydrogen cracking. For some pipeline operating conditions, the ability of the flowing contents to remove heat from the pipe wall tends to make the effective use of preheating difficult. Examples of typical temper-bead deposition sequences are shown in Figure B-1. To minimize the stress acting on the weld, attention should also be given to proper fit-up to minimize the stress concentration at the root of the weld.

The successful application of in-service welding must achieve a balance between safety on one hand and the prevention of unsatisfactory material properties on the other. For example, if the pipe wall is thin (i.e., less than 0.250 in. [6.4 mm]), it may be necessary to limit heat input to minimize the risk of burning through; however, a low heat input level may be insufficient to overcome the ability of the contents to remove heat from the pipe wall, resulting in excessive weld cooling rates and a subsequent risk of hydrogen cracking. Thus, a compromise must be reached. When the maximum allowable heat input to avoid burning through is insufficient to provide adequate protection against hydrogen cracking, then alternative precautions (e.g., a temper bead deposition sequence) must be used.

The majority of this appendix pertains to preventing hydrogen cracking in in-service welds. If the pipe wall thickness is less than 0.250 in. (6.4 mm), the risk of burning through should be considered. The previously mentioned thermal analysis computer models⁷ or another proven method should be used to determine heat input limits for these applications. Additional consideration should also be given for welding onto in-service pipelines and piping systems that contain products that become explosively unstable upon the application of heat, or that contain products that will affect the pipe material by rendering it susceptible to ignition, stress corrosion cracking, or embrittlement. Additional guidance can be found in API RP 2201.

The requirements for fillet welds in the main body of API Std 1104 should be applied to in-service welds that contact the carrier pipe, except for the alternative/ additional requirements specified in this appendix. For in-service welding, where discrepancies exist between this appendix and the main body, the appendix should govern.

B.2 Qualification of In-service Welding Procedures

The procedure qualification requirements for fillet welds in Section 5 should be applied to in-service welds, except for the alternative/additional requirements specified in this appendix.

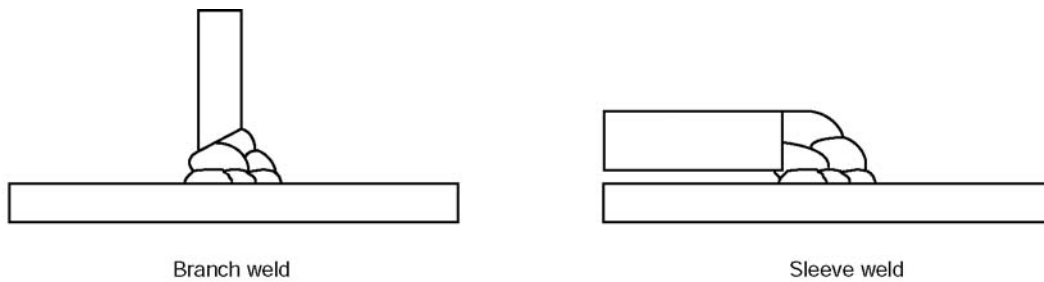

Notes:

1. A layer of weld metal buttering is first deposited using stringer beads.
2. Higher heat input levels are used for subsequent passes, which refine and temper the HAZ of the first layer.

Figure B-1—Examples of Typical Temper-bead Deposition Sequences

B.2.1 PROCEDURE SPECIFICATION**B.2.1.1 Specification Information****B.2.1.1.1 Pipe and Fitting Materials**

For in-service welds, the carbon equivalent⁸ of the materials to which the procedure applies should be identified in addition to specified minimum yield strength. Carbon equivalent levels may be grouped.

A procedure may be used for higher carbon equivalent materials than the material used for procedure qualification provided that the thermal conditions are less severe than the procedure qualification conditions and no increase in the risk of hydrogen cracking results.

B.2.1.1.2 Pipeline Operating Conditions

For in-service welds, the pipeline operating conditions (pipe contents, flow rate, etc.) for which the procedure applies should be identified. Conditions may be grouped.

B.2.1.1.3 Heat Input Range

For procedures intended to overcome the effect of the flowing contents by using a sufficiently high heat input level⁹ (heat input control procedures), the required heat input range should be specified.

B.2.1.1.4 Weld Deposition Sequence

For procedures intended to overcome the effect of the flowing contents by using temper bead deposition sequence (temper bead procedures), the required weld deposition sequence should be specified.

⁸ $CE_{IIW} = \%C + \%Mn/6 + (\%Cu + \%Ni)/15 + (\%Cr + \%Mo + \%V)/5$.

⁹Heat Input (kJ/in.) = (Amps × Volts × 60)/(Travel Speed [in./min] × 1000) – or – Heat Input (kJ/mm) = (Amps × Volts × 60)/(Travel speed [mm/min] × 1000)

B.2.2 ESSENTIAL VARIABLES**B.2.2.1 Changes Requiring Requalification****B.2.2.1.1 Pipe and Fitting Materials**

For in-service fillet welds, specified minimum yield strength is not an essential variable.

B.2.2.1.2 Pipeline Operating Conditions

For in-service welds, an increase in the severity of the pipeline operating conditions (in terms of weld cooling rates) above the group qualified constitutes an essential variable.

B.2.2.1.3 Pipe Wall Thickness

For in-service fillet welds, pipe wall thickness is not an essential variable.

B.2.2.1.4 Weld Deposition Sequence

A change from a temper bead deposition sequence to some other deposition sequence constitutes an essential variable.

B.2.3 WELDING OF TEST JOINTS

The requirements in 5.7 for branch and sleeve welds are appropriate for in-service welding. Pipeline operating conditions that affect the ability of the flowing contents to remove heat from the pipe wall should be simulated while test joints are being made.

Note: Filling the test section with water and allowing water to flow through the test section while the test joint is being made has been shown to produce thermal conditions equivalent to or more severe than typical in-service welding applications (see Figure B-2). Procedures qualified under these conditions are therefore suitable for any typical in-service application. Other media (e.g., motor oil) may be used to simulate less severe thermal conditions.

B.2.4 TESTING OF WELDED JOINTS

B.2.4.1 Preparation

The requirements in 5.8 are appropriate for in-service welding, except that test specimens should be cut from the joint at the locations shown in Figure B-3 and the minimum number of specimens and the tests to which they are to be subjected is shown in Table B-1.

B.2.4.2 Longitudinal Seam Welds

The longitudinal seam welds of full encirclement sleeves should be tested in accordance with 5.6. The backing material, if used, should be removed and the specimens may be flattened at room temperature before testing.

B.2.4.3 Branch and Sleeve Welds

Branch and sleeve welds should be tested in accordance with 5.8, except for testing of the additional specimens indicated in B.2.4.1.

B.2.4.4 Macro-section Tests—Branch and Sleeve Welds

B.2.4.4.1 Preparation

The macro-section test specimens (see Figure B-4) should be at least $1/2$ in. (13 mm) wide. They may be machine cut, or oxygen cut oversized and machined by a nonthermal process to remove at least $1/4$ in. (6 mm) from the side(s) that will be prepared. For each macro-section test specimen, at least one face should be ground to at least a 600 grit finish and etched with a suitable etchant, such as ammonium persulfate or dilute hydrochloric acid, to give a clear definition of the weld structure.

B.2.4.4.2 Visual Examination

The cross section of the weld is to be visually examined with lighting that will sufficiently reveal the details of the weld soundness. The use of optical devices or dye penetrants is not necessary.

B.2.4.4.3 Hardness Testing

Two of the four macro test specimens should be prepared for hardness testing in accordance with ASTM Standard E 92. A minimum of five indentations should be made using a Vickers indenter and a 10-kg load in the coarse-grained heat-affected zone (HAZ) at the weld toe of each specimen.

B.2.4.4.4 Requirements

A visual examination of the cross section of the weld should show that it is completely fused at the root and free of cracks. The fillet weld should have leg lengths that are at least

equal to the lengths specified in the procedure qualification and should not deviate in concavity or convexity by more than $1/16$ in. (1.6 mm). The depth of the undercutting should not exceed $1/32$ in. (0.8 mm) or 12 $1/2\%$ of the pipe wall thickness, whichever is smaller. Procedures that produce HAZ hardness values in excess of 350 HV should be evaluated with regard to the risk of hydrogen cracking.

B.2.4.5 Face-bend Test—Branch and Sleeve Welds

B.2.4.5.1 Preparation

The face-bend specimens (see Figure B-5) should be approximately 9 in. (230 mm) long and approximately 1 in. (25 mm) wide. They may be machine cut, or oxygen cut oversized and machined by a non-thermal process to remove at least $1/8$ in. (3 mm) from each side. The sides should be smooth and parallel, and the long edges rounded. The sleeve or branch and reinforcements should be removed flush with the surface, but not below the surface of the test specimen. Any undercut should not be removed.

Note: In lieu of taking separate specimens for the face-bend test, the remaining portion of the nick-break specimens may be used.

B.2.4.5.2 Method

The face-bend specimens should not be tested less than 24 hours after welding. The face-bend specimens should be bent in a guided-bend test jig similar to that shown in Figure 9. Each specimen should be placed on the die with the weld at mid span. The face of the weld should be placed toward the gap. The plunger should be forced into the gap until the curvature of the specimen is approximately U shaped.

B.2.4.5.3 Requirement

The face-bend test should be considered acceptable if, after bending, no crack or other imperfection exceeding $1/8$ in. (3 mm) or one-half the nominal wall thickness, whichever is smaller, in any direction is present in the weld metal or heat affected zone. Cracks that originate on the outer radius of the bend along the edges of the specimen during testing and that are less than $1/4$ in. (6 mm), measured in any direction, should not be considered unless obvious imperfections are observed.

B.3 In-service Welder Qualification

For in-service welding, the welder should be qualified to apply the specific procedure being used according to the requirements of 6.2, except for the alternative/additional requirements specified in this appendix.

A welder qualified on pipe having an outside diameter of less than 12.750 in. (323.9 mm) should be qualified for all diameters less than or equal to the diameter used in the qualification test. A welder qualified on pipe having an outside diameter of greater than or equal to 12.750 in. (323.9 mm)

should be qualified for all pipe diameters. A welder who has an existing multiple qualification to 6.3 and an in-service qualification to B.3 should be qualified as an in-service welder for all positions, all diameters, and all wall thicknesses within the limits of the essential variables in 6.3.

B.3.1 WELDING OF TEST JOINT

For in-service welding, pipeline operating conditions that affect the ability of the flowing contents to remove heat from the pipe wall should be simulated while test joints are being made.

Note: Filling the test section with water and allowing water to flow through the test section while the test joint is being made has been shown to produce thermal conditions equivalent to or more severe than typical in-service welding applications (see Figure B-2). Welders qualified under these conditions are therefore qualified for any typical in-service application. Other media (e.g., motor oil) may be used to simulate less severe thermal conditions.

In addition to making the test joint used for the destructive testing described in B.3.2, the welder should demonstrate to the satisfaction of the company the ability to comply with aspects of the welding procedure specification that are intended to avoid the development of crack-susceptible microstructures and/or prevention of burning through. For heat input control procedures, the welder should be able to demonstrate the ability to maintain a heat input level within the range specified in the procedure specification. For temper bead procedures, the welder should be able to demonstrate bead placement within the dimensional tolerances specified in the procedure specification.

B.3.2 TESTING OF WELDED JOINTS

The weld should be tested and considered to be acceptable if it meets the requirements of 6.4 and 6.5. For longitudinal seam welds, the minimum number of specimens and the tests to which they should be subjected is shown in Table B-2.

B.3.3 RECORDS

The pipeline operating conditions (pipe contents, flow rate, etc.) for which the welder is qualified should be identified. Conditions may be grouped.

B.4 Suggested In-service Welding Practices

The requirements for production welding in Section 7 should be applied to in-service welds, except for the alternative/additional requirements specified in this appendix.

Before welding onto an in-service pipeline or piping system, welders should consider aspects that affect safety, such as operating pressure, flow conditions, and wall thickness at the location of the welding. The areas to be welded should be inspected to ensure that imperfections are not present and that

the wall thickness is adequate. All welders performing repair work should be familiar with the safety precautions associated with cutting and welding on piping that contains or has contained crude petroleum, petroleum products, or fuel gases. Additional guidance can be found in API RP 2201.

B.4.1 ALIGNMENT

B.4.1.1 Fit-up

For sleeve and saddle welds, the gap between the sleeve or saddle and the carrier pipe should not be excessive. Clamping devices should be used to obtain proper fit-up. When necessary, weld metal build-up on the carrier pipe can be used to minimize the gap.

B.4.1.2 Root Opening—Longitudinal Seam Welds

For longitudinal butt welds of full encirclement sleeves, when 100% penetration is required, the root opening (the space between abutting edges) should be sufficient. These joints should be fitted with a mild steel back-up strip or suitable tape to prevent penetration of the weld into the carrier pipe.

Note: Penetration of the longitudinal butt weld into the carrier pipe is undesirable since any crack that might develop is exposed to the hoop stress in the carrier pipe.

B.4.2 WELDING SEQUENCE

Suggested sleeve and branch welding sequences are shown in Figures B-6 through B-11. For full-encirclement fittings requiring circumferential fillet welds, the longitudinal seams should be completed before beginning the circumferential welds. The circumferential weld at one end of the fitting should be completed before beginning the circumferential weld at the other end. For other types of fittings, a welding sequence that minimizes residual stress should be used.

B.5 Inspection and Testing of In-service Welds

The requirements for inspection and testing in Section 8 should be applied to in-service welds, except for the alternative/additional requirements specified in this appendix.

Since in-service welds that contact the carrier pipe may be particularly susceptible to underbead or delayed hydrogen cracking, an inspection method that is capable of detecting these cracks, particularly at the carrier pipe weld toe, should be used.

Note: Magnetic particle testing, ultrasonic testing, or a combination of both, using properly developed, qualified, and approved procedures, have been shown to be effective at detecting hydrogen cracks at the toe of sleeve-, saddle-, and branch-to-carrier pipe welds.

When determining appropriate delay times prior to inspection for hydrogen cracking, the time-dependant nature of

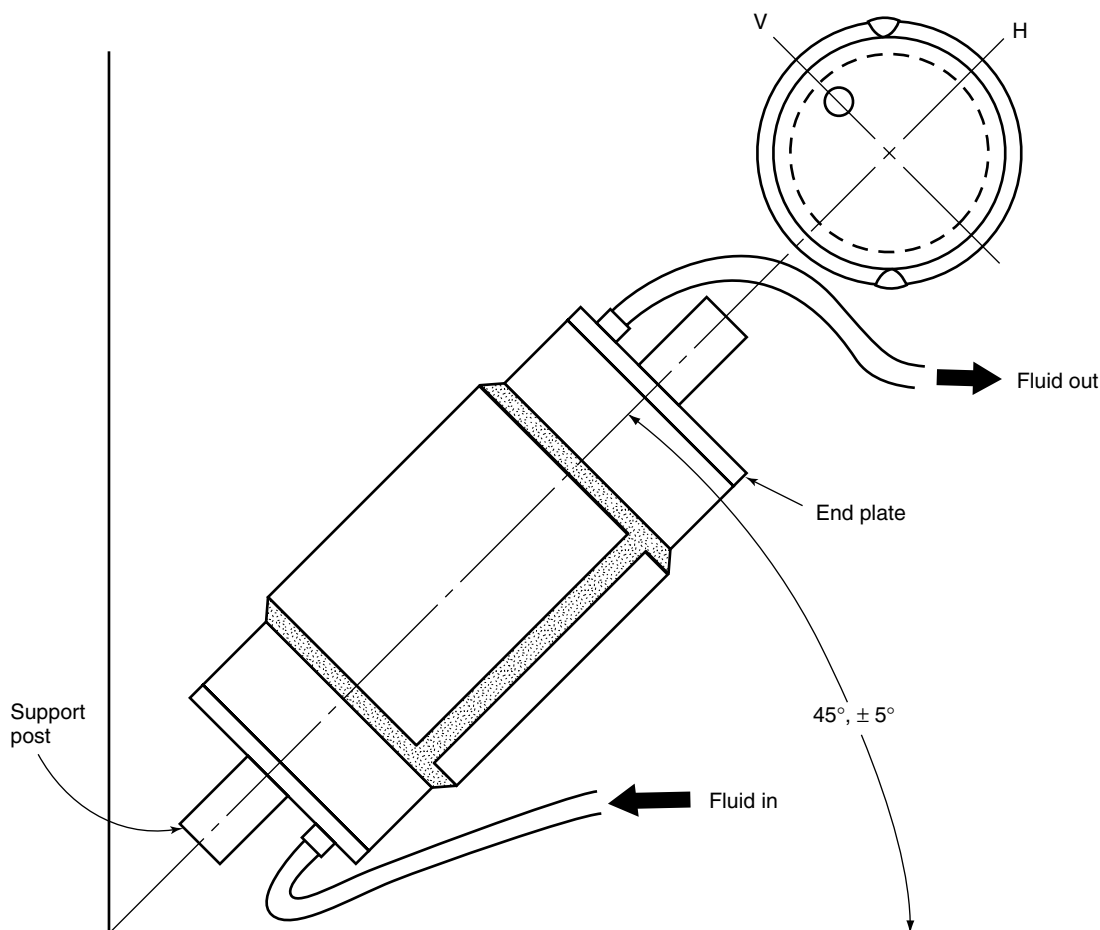

Note: This test position qualifies the procedure for all positions. Tests may be performed in other positions which will qualify the procedure for that position only.

Figure B-2—Suggested Procedure and Welder Qualification Test Assembly

cracking should be considered, as well as the probability of the weld to cracking. Longer delay times decrease the chance that cracking can occur after inspection has been completed. The probability of cracking, and thus the importance of determining an appropriate delay time, can be minimized by using more conservative welding procedures.

B.6 Standards of Acceptability: Nondestructive Testing (Including Visual)

The standards of acceptability in Section 9 for imperfections located by nondestructive testing should be applied to in-service welds.

B.7 Repair and Removal of Defects

The requirements in Section 10 for the repair and removal of defects should be applied to in-service welds. Care should be taken during the removal of the defect to ensure that the wall thickness is not reduced to less than that which is acceptable for the operating pressure of the carrier pipe.

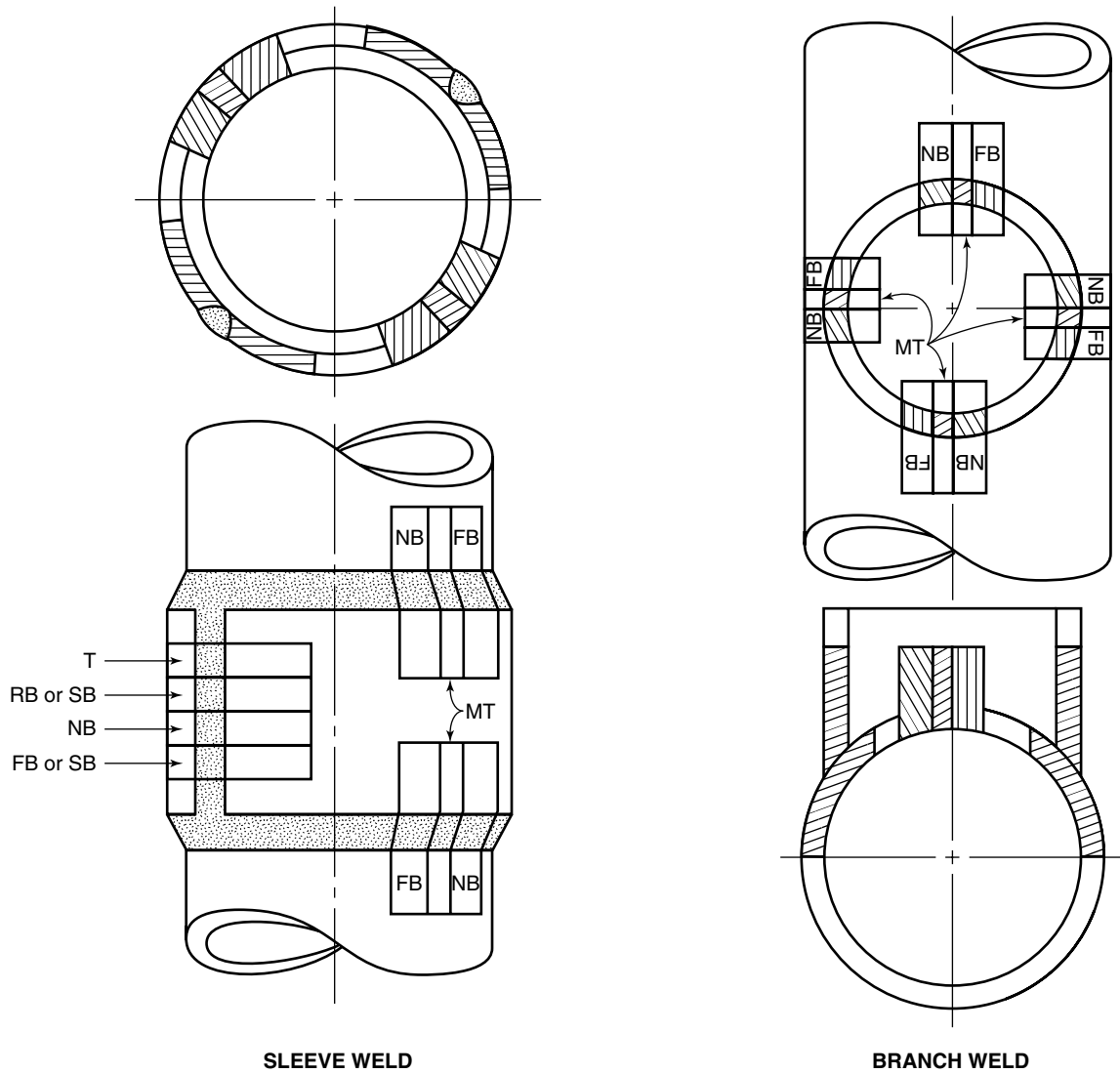

Note: T = tensile; RB = root bend; FB = face bend; NB = nick break; SB = side bend; MT = macro test.

Figure B-3—Location of Test Specimens—In-service Welding Procedure Qualification Test

Table B-1—Type and Number of Specimens—In-service Welding Procedure Qualification Test

Wall Thickness	Weld Type	Number of Specimens ^a						Total
		Tensile	Nick-break	Root Bend	Face Bend	Side Bend	Macro Test	
≤ 0.500 in. (12.7 mm)	Groove	2	2	2	2			8
	Sleeve		4 ^b		4		4	12
	Branch		4 ^b		4		4	12
> 0.500 in. (12.7 mm)	Groove	2	2			4		8
	Sleeve		4 ^b		4		4	12
	Branch		4 ^b		4		4	12

^aFor pipe or branch outside diameter less than or equal to 4.500 in. (114.3 mm), two welds may be required.

^bAt the owner's option, the remaining portion of these specimens may be prepared for and submitted to the face-bend test (see B.2.4.5) after they are submitted to the Nick-break test.

Table B-2—Type and Number of Test Specimens for Longitudinal Seam Welds—Welder Qualification Test

Wall Thickness	Number of Specimens					Total
	Tensile	Nick Break	Root Bend	Face Bend	Side Bend	
≤ 0.500 in. (12.7 mm)	1	1	1	1		4
> 0.500 in. (12.7 mm)	1	1			2	4

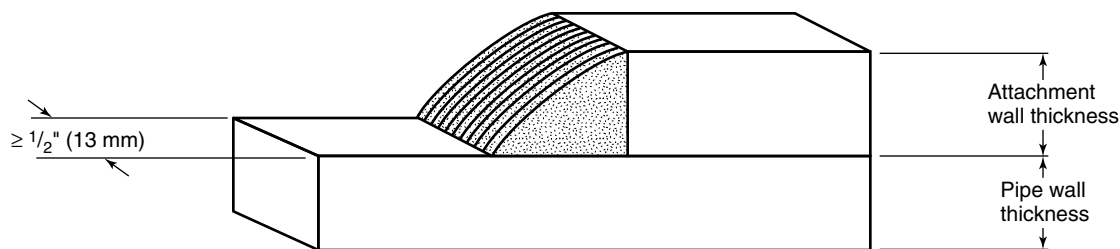

Note: Smooth and etch at least one face of each weld specimen cross section with a suitable etchant to give a clear definition to the weld structure.

Figure B-4—Macro Test Specimen—In-service Welds

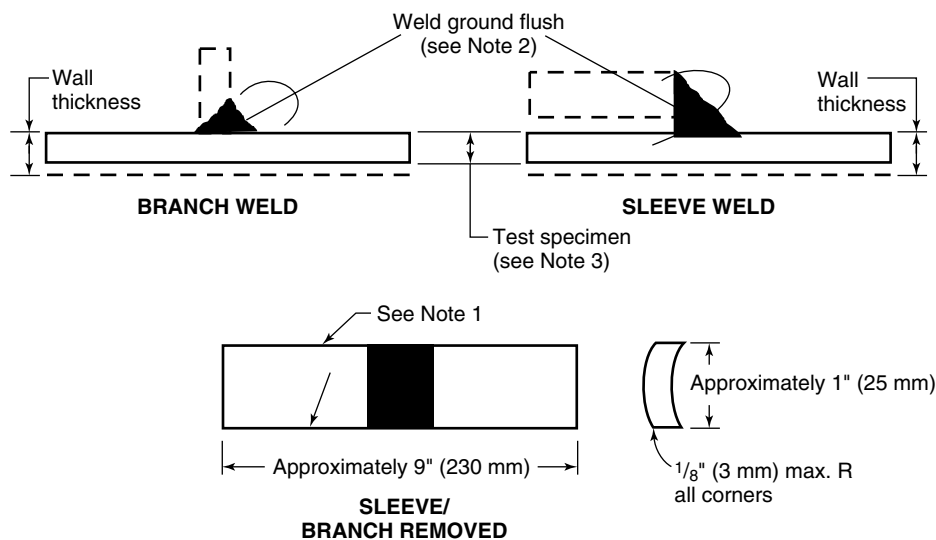

Notes:

1. Test specimens may be machine cut or oxygen cut oversized and machined (see B.2.4.5.1).
2. The sleeve or branch weld reinforcement should be removed flush with the surface of the test specimen. The branch weld test specimen is shown in the axial direction; specimens in the other direction are curved. Test specimens should not be flattened prior to testing.
3. Where wall thickness is greater than 0.500 in. (12.7 mm), it may be reduced to 0.500 in. (12.7 mm) by machining the inside surface.
4. In lieu of taking separate specimens for the face bend test, the remaining portion of the nick-break specimens may be used.

Figure B-5—Face-bend Test Specimen

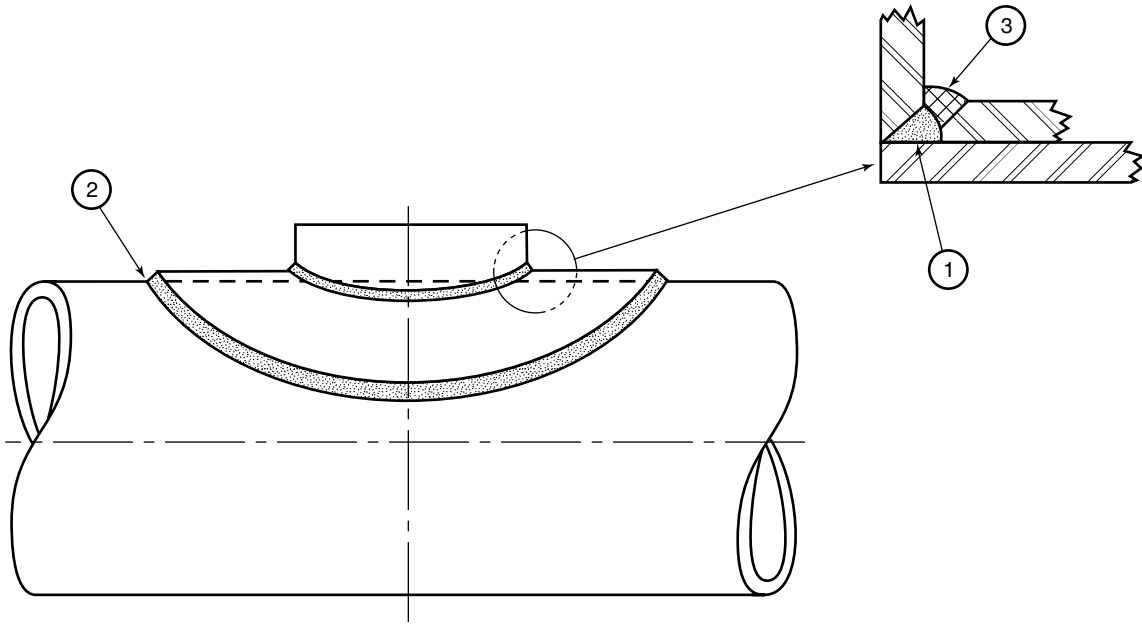

Note: This is the suggested welding sequence; others may be followed at the discretion of the company.

Figure B-6—Reinforcing Pad

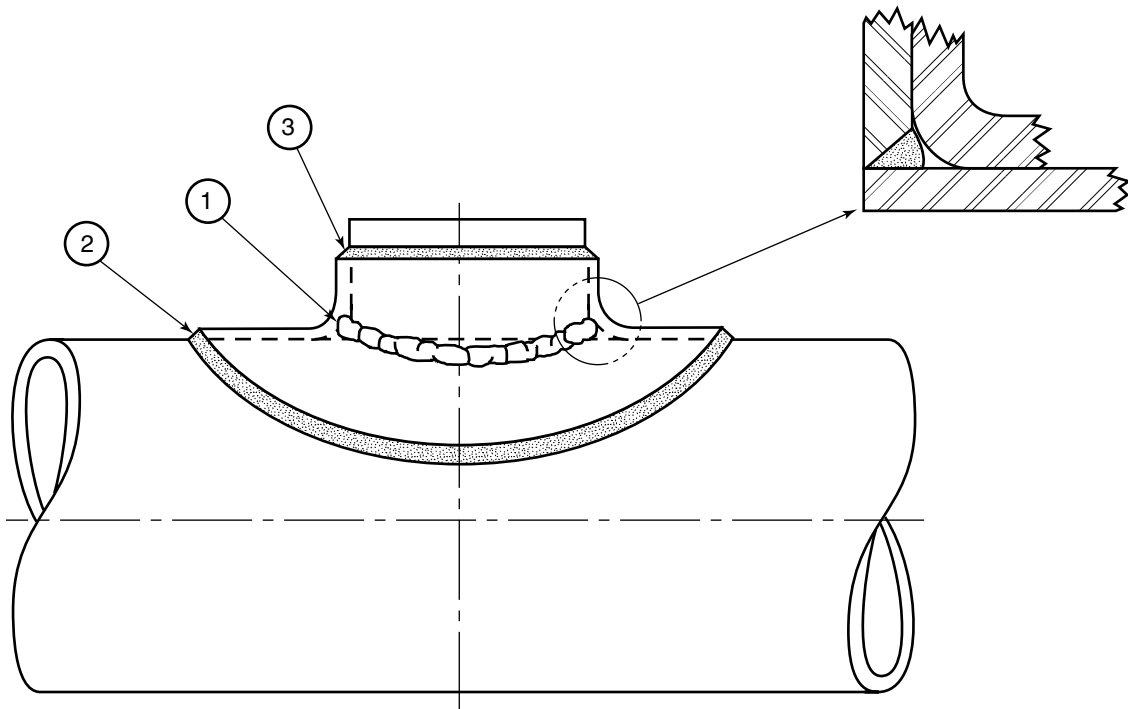

Note: This is the suggested welding sequence; others may be followed at the discretion of the company.

Figure B-7—Reinforcing Saddle

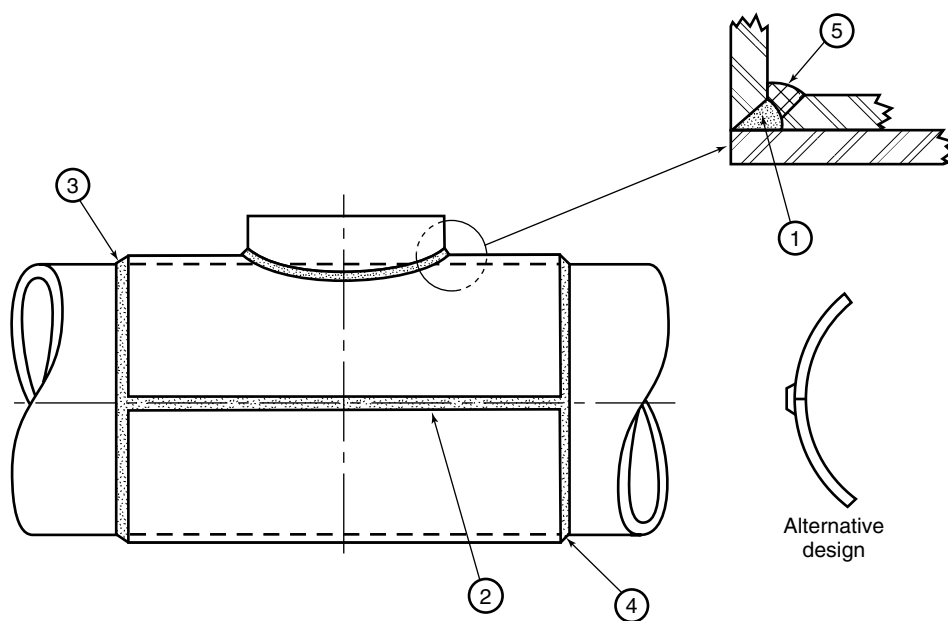

Note: This is the suggested welding sequence; at the discretion of the company, others may be followed and circumferential welds, numbers 3 and 4 need not be made.

Figure B-8—Encirclement Sleeve

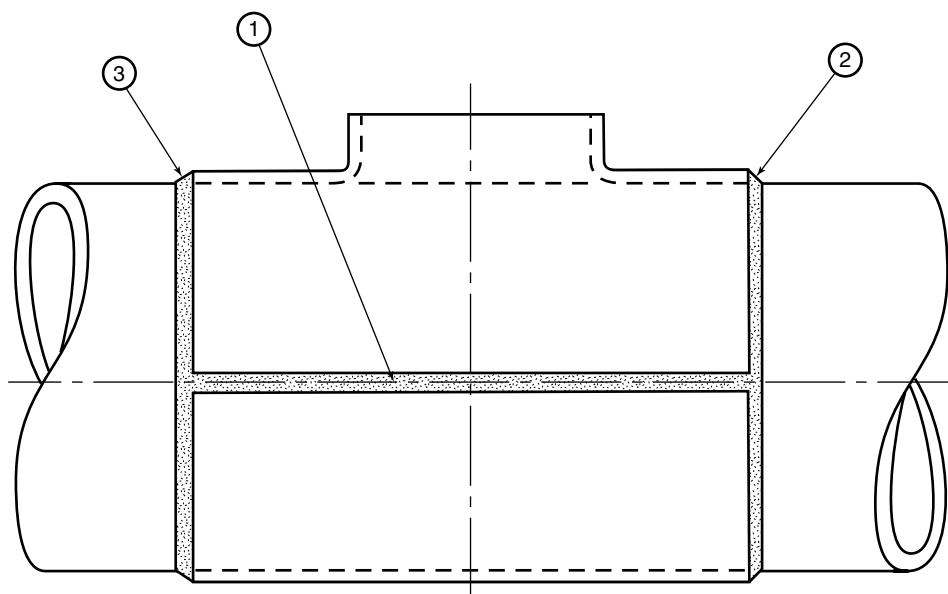

Notes:
 1. This is the suggested welding sequence; others may be followed at the discretion of the company.
 2. When in operation, the fitting is at pipeline pressure.

Figure B-9—Encirclement Tee

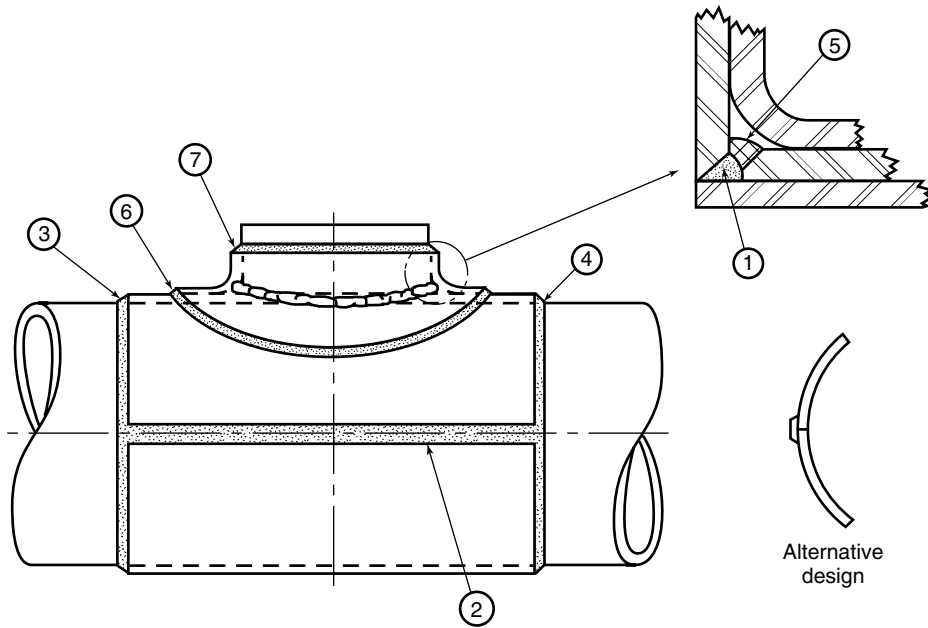

Note: This is the suggested welding sequence; at the discretion of the company, others may be followed and circumferential welds, numbers 3 and 4 need not be made.

Figure B-10—Encirclement Sleeve and Saddle

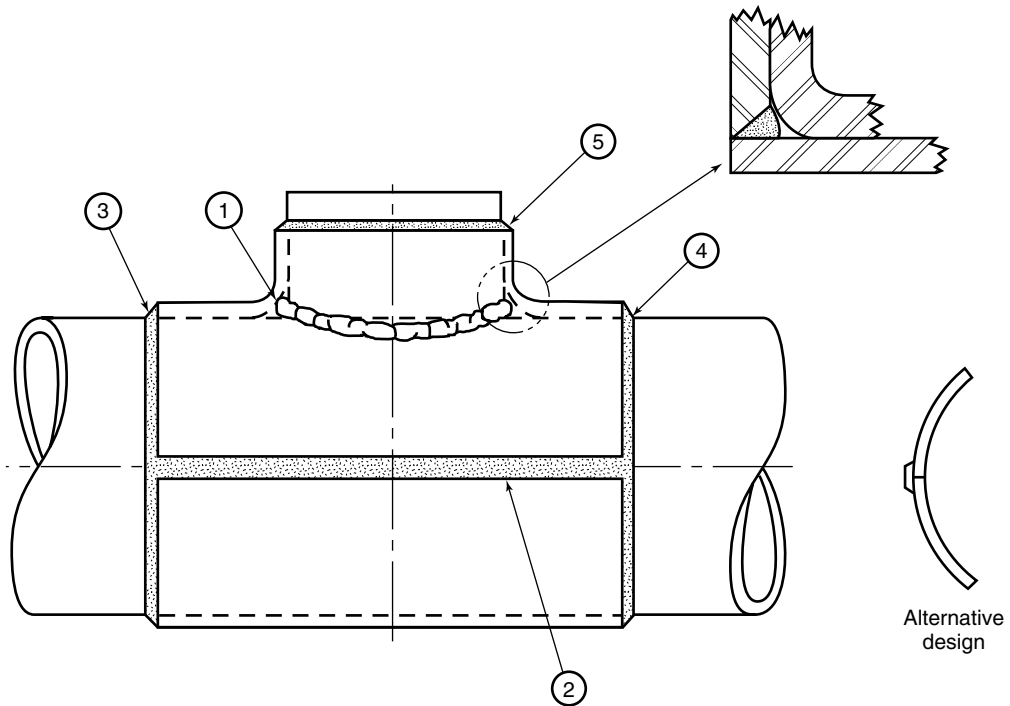

Note: This is the suggested welding sequence; at the discretion of the company, others may be followed and circumferential welds, numbers 3 and 4 need not be made.

Figure B-11—Encirclement Saddle



**American Petroleum Institute
2005 Publications Order Form**

Effective January 1, 2005.

API Members receive a 30% discount where applicable.

The member discount does not apply to purchases made for the purpose of resale or for incorporation into commercial products, training courses, workshops, or other commercial enterprises.

Available through Global Engineering Documents:

Phone Orders: 1-800-854-7179 (Toll-free in the U.S. and Canada)
303-397-7956 (Local and International)

Fax Orders: 303-397-2740

Online Orders: www.global.ihs.com

Date: _____

API Member (Check if Yes)

Invoice To (Check here if same as "Ship To")

Name: _____
Title: _____
Company: _____
Department: _____
Address: _____

City: _____ State/Province: _____
Zip/Postal Code: _____ Country: _____
Telephone: _____
Fax: _____
E-Mail: _____

Ship To (UPS will not deliver to a P.O. Box)

Name: _____
Title: _____
Company: _____
Department: _____
Address: _____

City: _____ State/Province: _____
Zip/Postal Code: _____ Country: _____
Telephone: _____
Fax: _____
E-Mail: _____

Quantity	Product Number	Title	SO★	Unit Price	Total

Payment Enclosed **P.O. No.** (Enclose Copy) _____

Charge My Global Account No. _____

VISA **MasterCard** **American Express** **Diners Club** **Discover**

Credit Card No.: _____

Print Name (As It Appears on Card): _____

Expiration Date: _____

Signature: _____

Subtotal	
Applicable Sales Tax (see below)	
Rush Shipping Fee (see below)	
Shipping and Handling (see below)	
Total (in U.S. Dollars)	

★ To be placed on **Standing Order** for future editions of this publication, place a check mark in the SO column and sign here:

Pricing and availability subject to change without notice.

Mail Orders – Payment by check or money order in U.S. dollars is required except for established accounts. State and local taxes, \$10 processing fee*, and 5% shipping must be added. Send mail orders to: **API Publications, Global Engineering Documents, 15 Inverness Way East, M/S C303B, Englewood, CO 80112-5776, USA.**

Purchase Orders – Purchase orders are accepted from established accounts. Invoice will include actual freight cost, a \$10 processing fee*, plus state and local taxes.

Telephone Orders – If ordering by telephone, a \$10 processing fee* and actual freight costs will be added to the order.

Sales Tax – All U.S. purchases must include applicable state and local sales tax. Customers claiming tax-exempt status must provide Global with a copy of their exemption certificate.

Shipping (U.S. Orders) – Orders shipped within the U.S. are sent via traceable means. Most orders are shipped the same day. Subscription updates are sent by First-Class Mail. Other options, including next-day service, air service, and fax transmission are available at additional cost. Call 1-800-854-7179 for more information.

Shipping (International Orders) – Standard international shipping is by air express courier service. Subscription updates are sent by World Mail. Normal delivery is 3-4 days from shipping date.

Rush Shipping Fee – Next Day Delivery orders charge is \$20 in addition to the carrier charges. Next Day Delivery orders must be placed by 2:00 p.m. MST to ensure overnight delivery.

Returns – All returns must be pre-approved by calling Global's Customer Service Department at 1-800-624-3974 for information and assistance. There may be a 15% restocking fee. Special order items, electronic documents, and age-dated materials are non-returnable.

***Minimum Order** – There is a \$50 minimum for all orders containing hardcopy documents. The \$50 minimum applies to the order subtotal including the \$10 processing fee, excluding any applicable taxes and freight charges. If the total cost of the documents on the order plus the \$10 processing fee is less than \$50, the processing fee will be increased to bring the order amount up to the \$50 minimum. This processing fee will be applied before any applicable deposit account, quantity or member discounts have been applied. There is no minimum for orders containing only electronically delivered documents.

There's more where this came from.

The American Petroleum Institute provides additional resources and programs to the oil and natural gas industry which are based on API® Standards. For more information, contact:

- API Monogram® Licensing Program Phone: 202-962-4791
Fax: 202-682-8070
- American Petroleum Institute Quality Registrar (APIQR®) Phone: 202-962-4791
Fax: 202-682-8070
- API Spec Q1® Registration Phone: 202-962-4791
Fax: 202-682-8070
- API Perforator Design Registration Phone: 202-962-4791
Fax: 202-682-8070
- API ISO/TS 29001 Registration Phone: 202-962-4791
Fax: 202-682-8070
- API Training Provider Certification Program Phone: 202-682-8490
Fax: 202-682-8070
- Individual Certification Programs Phone: 202-682-8064
Fax: 202-682-8348
- Engine Oil Licensing and Certification System (EOLCS) Phone: 202-682-8516
Fax: 202-962-4739
- API PetroTEAM™ (Training, Education and Meetings) Phone: 202-682-8195
Fax: 202-682-8222

Check out the API Publications, Programs, and Services Catalog online at www.api.org.



Helping You Get
The Job Done Right.®

.....

Additional copies are available through Global Engineering Documents at (800) 854-7179 or (303) 397-7956

Information about API Publications, Programs and Services is available on the World Wide Web at: <http://www.api.org>



1220 L Street, Northwest
Washington, D.C. 20005-4070

Product No. D110420