

AWS A5.1/A5.1M:2012
An American National Standard



Specification for Carbon Steel Electrodes for Shielded Metal Arc Welding



American Welding Society®



**AWS A5.1/A5.1M:2012
An American National Standard**

**Approved by the
American National Standards Institute
April 10, 2012**

Specification for Carbon Steel Electrodes for Shielded Metal Arc Welding

14th Edition

Supersedes AWS A5.1/A5.1M:2004

Prepared by the
American Welding Society (AWS) A5 Committee on Filler Metals and Allied Materials

Under the Direction of the
AWS Technical Activities Committee

Approved by the
AWS Board of Directors

Abstract

This specification establishes the requirements for classification of carbon steel electrodes for shielded metal arc welding. The requirements include mechanical properties of weld metal, weld metal soundness, and usability of electrode. Requirements for composition of the weld metal, moisture content of low-hydrogen electrode coverings, standard sizes and lengths, marking, manufacturing, and packaging are also included. A guide to the use of the standard is included in an annex.

Optional supplemental requirements include improved toughness and ductility, lower moisture contents, and diffusible hydrogen limits.

This specification makes use of both U.S. Customary Units and the International System of Units (SI). Since these are not equivalent, each system must be used independently of the other.



American Welding Society®

8669 Doral Blvd., Doral, FL 33166

International Standard Book Number: 978-0-87171-810-5
American Welding Society
8669 Doral Blvd., Doral, FL 33166
© 2012 by American Welding Society
All rights reserved
Printed in the United States of America

Photocopy Rights. No portion of this standard may be reproduced, stored in a retrieval system, or transmitted in any form, including mechanical, photocopying, recording, or otherwise, without the prior written permission of the copyright owner.

Authorization to photocopy items for internal, personal, or educational classroom use only or the internal, personal, or educational classroom use only of specific clients is granted by the American Welding Society provided that the appropriate fee is paid to the Copyright Clearance Center, 222 Rosewood Drive, Danvers, MA 01923, tel: (978) 750-8400; Internet: <www.copyright.com>.

Statement on the Use of American Welding Society Standards

All standards (codes, specifications, recommended practices, methods, classifications, and guides) of the American Welding Society (AWS) are voluntary consensus standards that have been developed in accordance with the rules of the American National Standards Institute (ANSI). When AWS American National Standards are either incorporated in, or made part of, documents that are included in federal or state laws and regulations, or the regulations of other governmental bodies, their provisions carry the full legal authority of the statute. In such cases, any changes in those AWS standards must be approved by the governmental body having statutory jurisdiction before they can become a part of those laws and regulations. In all cases, these standards carry the full legal authority of the contract or other document that invokes the AWS standards. Where this contractual relationship exists, changes in or deviations from requirements of an AWS standard must be by agreement between the contracting parties.

AWS American National Standards are developed through a consensus standards development process that brings together volunteers representing varied viewpoints and interests to achieve consensus. While AWS administers the process and establishes rules to promote fairness in the development of consensus, it does not independently test, evaluate, or verify the accuracy of any information or the soundness of any judgments contained in its standards.

AWS disclaims liability for any injury to persons or to property, or other damages of any nature whatsoever, whether special, indirect, consequential, or compensatory, directly or indirectly resulting from the publication, use of, or reliance on this standard. AWS also makes no guarantee or warranty as to the accuracy or completeness of any information published herein.

In issuing and making this standard available, AWS is neither undertaking to render professional or other services for or on behalf of any person or entity, nor is AWS undertaking to perform any duty owed by any person or entity to someone else. Anyone using these documents should rely on his or her own independent judgment or, as appropriate, seek the advice of a competent professional in determining the exercise of reasonable care in any given circumstances. It is assumed that the use of this standard and its provisions is entrusted to appropriately qualified and competent personnel.

This standard may be superseded by new editions. This standard may also be corrected through publication of amendments or errata, or supplemented by publication of addenda. Information on the latest editions of AWS standards including amendments, errata, and addenda is posted on the AWS web page (www.aws.org). Users should ensure that they have the latest edition, amendments, errata, and addenda.

Publication of this standard does not authorize infringement of any patent or trade name. Users of this standard accept any and all liabilities for infringement of any patent or trade name items. AWS disclaims liability for the infringement of any patent or product trade name resulting from the use of this standard.

AWS does not monitor, police, or enforce compliance with this standard, nor does it have the power to do so.

Official interpretations of any of the technical requirements of this standard may only be obtained by sending a request, in writing, to the appropriate technical committee. Such requests should be addressed to the American Welding Society, Attention: Managing Director, Technical Services Division, 8669 Doral Blvd., Doral, FL 33166 (see Annex B). With regard to technical inquiries made concerning AWS standards, oral opinions on AWS standards may be rendered. These opinions are offered solely as a convenience to users of this standard, and they do not constitute professional advice. Such opinions represent only the personal opinions of the particular individuals giving them. These individuals do not speak on behalf of AWS, nor do these oral opinions constitute official or unofficial opinions or interpretations of AWS. In addition, oral opinions are informal and should not be used as a substitute for an official interpretation.

This standard is subject to revision at any time by the AWS A5 Committee on Filler Metals and Allied Materials. It must be reviewed every five years, and if not revised, it must be either reaffirmed or withdrawn. Comments (recommendations, additions, or deletions) and any pertinent data that may be of use in improving this standard are required and should be addressed to AWS Headquarters. Such comments will receive careful consideration by the AWS A5 Committee on Filler Metals and Allied Materials and the author of the comments will be informed of the Committee's response to the comments. Guests are invited to attend all meetings of the AWS A5 Committee on Filler Metals and Allied Materials to express their comments verbally. Procedures for appeal of an adverse decision concerning all such comments are provided in the Rules of Operation of the Technical Activities Committee. A copy of these Rules can be obtained from the American Welding Society, 8669 Doral Blvd., Doral, FL 33166.

This page is intentionally blank.

Personnel

AWS A5 Committee on Filler Metals and Allied Materials

H. D. Wehr, Chair	<i>Arcos Industries, LLC</i>
J. J. DeLoach, Jr., 1st Vice Chair	<i>Naval Surface Warfare Center</i>
R. D. Fuchs, 2nd Vice Chair	<i>Böhler Welding Group USA, Incorporated</i>
R. K. Gupta, Secretary	<i>American Welding Society</i>
T. Anderson	<i>Miller Electric Manufacturing Company</i>
J. M. Blackburn	<i>Naval Sea Systems Command</i>
J. C. Bundy	<i>Hobart Brothers Company</i>
D. D. Crockett	<i>Consultant</i>
R. V. Decker	<i>Weldstar</i>
D. A. DelSignore	<i>Consultant</i>
J. DeVito	<i>ESAB Welding and Cutting Products</i>
H. W. Ebert	<i>Consultant</i>
D. M. Fedor	<i>The Lincoln Electric Company</i>
J. G. Feldstein	<i>Foster Wheeler North America</i>
S. E. Ferree	<i>ESAB Welding and Cutting Products</i>
D. A. Fink	<i>The Lincoln Electric Company</i>
G. L. Franke	<i>Naval Surface Warfare Center</i>
R. M. Henson	<i>J. W. Harris Company, Incorporated</i>
S. D. Kiser	<i>Special Metals</i>
P. J. Konkol	<i>Concurrent Technologies Corporation</i>
D. J. Kotecki	<i>Damian Kotecki Welding Consultants</i>
L. G. Kvidahl	<i>Ingalls Shipbuilding</i>
A. Y. Lau	<i>Canadian Welding Bureau</i>
J. S. Lee	<i>Chevron</i>
T. Melfi	<i>The Lincoln Electric Company</i>
R. Menon	<i>Stoody Company</i>
K. M. Merlo	<i>EWI</i>
M. T. Merlo	<i>RevWires LLC</i>
B. Mosier	<i>Polymet Corporation</i>
A. K. Mukherjee	<i>Siemens Energy, Incorporated</i>
T. C. Myers	<i>Oceaneering Intervention Engineering</i>
C. L. Null	<i>Consultant</i>
B. A. Pletcher	<i>CB&I, Incorporated</i>
K. C. Pruden	<i>Hydril Company</i>
K. Roossinck	<i>Ingalls Shipbuilding</i>
P. K. Salvesen	<i>Det Norske Veritas (DNV)</i>
K. Sampath	<i>Consultant</i>
W. S. Severance	<i>ESAB Welding and Cutting Products</i>
M. F. Sinfield	<i>Naval Surface Warfare Center</i>
M. J. Sullivan	<i>NASSCO–National Steel and Shipbuilding</i>
R. C. Sutherlin	<i>ATI Wah Chang</i>
R. A. Swain	<i>Euroweld, Limited</i>
K. P. Thornberry	<i>Care Medical, Incorporated</i>
M. D. Tumuluru	<i>U.S. Steel Corporation</i>
H. J. White	<i>HAYNES International</i>

Advisors to the AWS A5 Committee on Filler Metal and Allied Material

R. L. Bateman	<i>Soldaduras West Arco Limitada</i>
J. E. Beckham	<i>Chrysler LLC</i>
R. A. Daemen	<i>Consultant</i>
C. E. Fuerstenau	<i>Lucas-Milhaupt, Incorporated</i>
J. P. Hunt	<i>Special Metals</i>
S. Imaoka	<i>Kobe Steel, Limited</i>
W. A. Marttila	<i>WAMcom Consulting LLC</i>
D. R. Miller	<i>ABS Americas Materials Department</i>
M. P. Parekh	<i>Consultant</i>
M. A. Quintana	<i>The Lincoln Electric Company</i>
E. S. Surian	<i>National University of Lomas de Zamora</i>

AWS A5A Subcommittee on Carbon and Low Alloy Steel Electrodes

G. L. Franke, Chair	<i>Naval Surface Warfare Center</i>
R. A. Swain, Vice Chair	<i>Euroweld, Limited</i>
R. K. Gupta, Secretary	<i>American Welding Society</i>
R. V. Decker	<i>Weldstar Company</i>
J. J. DeLoach, Jr.	<i>Naval Surface Warfare Center</i>
H. W. Ebert	<i>Consultant</i>
K. K. Gupta	<i>Westinghouse Electric Corporation</i>
M. James	<i>The Lincoln Electric Company</i>
S. J. Knostman	<i>Hobart Brothers</i>
A. Y. Lau	<i>Canadian Welding Bureau</i>
T. C. Myers	<i>Oceaneering Intervention Engineering</i>
M. P. Parekh	<i>Consultant</i>
M. A. Quintana	<i>The Lincoln Electric Company</i>
P. K. Salvesen	<i>Det Norske Veritas (DNV)</i>
K. Sampath	<i>Consultant</i>
M. S. Sierdzinski	<i>ESAB Welding & Cutting Products</i>

Advisors to the AWS A5A Subcommittee on Carbon and Low Alloy Steel Electrodes

S. Imaoka	<i>Kobe Steel, Limited</i>
D. J. Kotecki	<i>Damian Kotecki Welding Consultants</i>
D. R. Miller	<i>ABS Americas Materials Department</i>
M. D. Tumuluru	<i>U.S. Steel Corporation</i>

Foreword

This foreword is not part of AWS A5.1/A5.1M:2012, *Specification for Carbon Steel Electrodes for Shielded Metal Arc Welding*, but is included for informational purposes only.

This specification is the latest revision of the first filler metal specification issued over 70 years ago. The initial 1940 document and the three revisions within the next five years were prepared by a joint committee of the American Society for Testing and Materials and the American Welding Society. However, they were issued with only an ASTM specification designation. The 1948 revision was the first specification issued with the AWS designation appearing on the document. The 1969 revision was the first time that the document was issued without the ASTM designation.

This document is the second of the A5.1 specifications which makes use of both U.S. Customary Units and the International System of Units (SI). The dimensions are not exact equivalents in the two systems. Previous A5.1 specifications showed an approximate conversion to SI units for informational purposes only. This practice is discontinued. Instead SI units used are hard conversions to rational units. In selecting rational metric units, AWS A1.1, *Metric Practice Guide for the Welding Industry*, and International Standard ISO 544, *Welding consumables — Technical delivery conditions for welding filler materials — Type of product, dimensions, tolerances and markings*, are used where suitable. Tables and figures make use of both U.S. Customary and SI Units, which, with the application of the specified tolerances, provides for interchangeability of products in both the U.S. Customary and SI Units.

Substantive changes in this revision include adding of boron reporting requirement in Table 7, and updating Clause 6, Rounding-Off Procedure. These changes are shown in *italic* font.

Document Development:

ASTM A 233-40T	<i>Tentative Specifications for Iron and Steel Arc-Welding Electrodes</i>
ASTM A 233-42T	<i>Tentative Specifications for Iron and Steel Arc-Welding Electrodes</i>
ASTM A 233-43T	<i>Tentative Specifications for Iron and Steel Arc-Welding Electrodes</i>
ASTM A 233-45T	<i>Tentative Specifications for Iron and Steel Arc-Welding Electrodes</i>
ASTM A 233-48T	<i>Tentative Specifications for Mild Steel Arc Welding Electrodes</i>
AWS A5.1-48T	
ASTM A 233-55T	<i>Tentative Specifications for Mild Steel Arc Welding Electrodes</i>
AWS A5.1-55T	
ASTM A 233-58T	<i>Tentative Specification for Mild Steel Arc Welding Electrodes</i>
AWS A5.1-58T	
AWS A5.1-64T	<i>Tentative Specification for Mild Steel Covered Arc Welding Electrodes</i>
ASTM A 233-64T	
AWS A5.1-69	<i>Specification for Mild Steel Covered Arc Welding Electrodes</i>
ANSI W3.1-1973	
ANSI/AWS A5.1-78	<i>Specification for Carbon Steel Covered Arc-Welding Electrodes</i>
ANSI/AWS A5.1-81	<i>Specification for Carbon Steel Covered Arc-Welding Electrodes</i>
ANSI/AWS A5.1-91	<i>Specification for Carbon Steel Electrodes for Shielded Metal Arc Welding</i>
AWS A5.1/A5.1M:2004	<i>Specification for Carbon Steel Electrodes for Shielded Metal Arc Welding</i>

Comments and suggestions for the improvement of this standard are welcomed. They should be sent to the Secretary, AWS A5 Committee on Filler Metals and Allied Materials, American Welding Society, 8669 Doral Blvd., Doral, FL 33166.

This page is intentionally blank.

Table of Contents

	Page No.
<i>Personnel</i>	v
<i>Foreword</i>	vii
<i>List of Tables</i>	x
<i>List of Figures</i>	x
1. Scope	1
Part A—General Requirements	1
2. Normative References	1
3. Classification	2
4. Acceptance	2
5. Certification	2
6. Rounding-Off Procedure	3
Part B—Tests, Procedures, and Requirements	4
7. Summary of Tests	4
8. Retest	4
9. Weld Test Assemblies	5
10. Chemical Analysis	13
11. Radiographic Test	13
12. Tension Test	19
13. Bend Test	20
14. Impact Test	20
15. Fillet Weld Test	20
16. Moisture Test	22
17. Absorbed Moisture Test	22
18. Diffusible Hydrogen Test	24
Part C—Manufacture, Identification, and Packaging	25
19. Method of Manufacture	25
20. Standard Sizes and Lengths	25
21. Core Wire and Covering	26
22. Exposed Core	26
23. Electrode Identification	26
24. Packaging	26
25. Marking of Packages	27
Annex A (Informative)—Guide to AWS Specification for Carbon Steel Electrodes for Shielded Metal Arc Welding	29
Annex B (Informative)—Guidelines for the Preparation of Technical Inquiries	45
AWS Filler Metal Specifications by Material and Welding Process	47
AWS Filler Metal Specifications and Related Documents	49

List of Tables

Table	Page No.
1 Electrode Classification	3
2 Tension Test Requirements	4
3 Charpy V-Notch Impact Requirements	5
4 Required Tests	6
5 Base Metal for Test Assemblies	14
6 Requirements for Preparation of Fillet Weld Test Assemblies	14
7 Chemical Composition Requirements for Weld Metal	16
8 Radiographic Soundness Requirements	19
9 Dimensional Requirements for Fillet Weld Usability Test Specimens	21
10 Moisture Content Limits for Electrode Coverings	23
11 Diffusible Hydrogen Limits for Weld Metal	24
12 Standard Sizes and Lengths	25
A.1 Canadian Electrode Classifications Similar to AWS Classifications	30
A.2 Comparison of Equivalent Classifications	32
A.3 Typical Storage and Drying Conditions for Covered Arc Welding Electrodes	35
A.4 Typical Amperage Ranges	37
A.5 Discontinued Electrode Classifications	43

List of Figures

Figure	Page No.
1 Pad for Chemical Analysis of Undiluted Weld Metal	8
2 Groove Weld Test Assembly for Mechanical Properties and Soundness of Weld Metal Produced by Using All Electrode Classifications Except E6022 [E4322] and E7018M [E4918M] Electrodes	9
3 Fillet Weld Test Assembly	10
4 Test Assembly for Transverse Tension and Longitudinal Guided Bend Tests for Welds Made with E6022 [E4322] Electrodes	11
5 Groove Weld Test Assembly for Mechanical Properties and Soundness of Weld Metal Produced by Using E7018M [E4918M] Electrodes	12
6 Welding Positions for Fillet Weld Test Assemblies	15
7 Radiographic Acceptance Standards for Rounded Indications (Grades 1 and 2)	17
8 Dimensions of Fillet Welds	21
9 Alternative Methods for Facilitating Fracture of the Fillet Weld	22
10 Order of Mandatory and Optional Supplemental Designators	27

Specification for Carbon Steel Electrodes for Shielded Metal Arc Welding

1. Scope

1.1 This specification prescribes requirements for the classification of carbon steel electrodes for shielded metal arc welding.

1.2 Safety and health issues and concerns are beyond the scope of this standard and, therefore, are not fully addressed herein. Some safety and health information can be found in Informative Annex Clauses A5 and A10. Safety and health information is available from other sources, including, but not limited to, ANSI Z49.1, *Safety in Welding, Cutting, and Allied Processes*,¹ and applicable federal and state regulations.

1.3 This specification makes use of both U.S. Customary Units and the International System of Units (SI).

The measurements are not exact equivalents; therefore, each system must be used independently of the other without combining in any way when referring to material properties. The specification with the designation A5.1 uses U.S. Customary Units. The specification A5.1M uses SI Units. The latter are shown within brackets ([]) or in appropriate columns in tables and figures. Standard dimensions based on either system may be used for sizing of filler metal or packaging or both under A5.1 or A5.1M specifications.

Part A *General Requirements*

2. Normative References

The following standards contain provisions which, through reference in this text, constitute provisions of this AWS standard. For dated references, subsequent amendments to, or revisions of, any of these publications do not apply. However parties to agreement based on this AWS standard are encouraged to investigate the possibility of applying the most recent editions of the documents shown below. For undated references, the latest edition of the standard referenced applies.

The following documents are referenced in the mandatory sections of this document:

(1) ASTM E29, *Standard Practice for Using Significant Digits in Test Data to Determine Conformance with Specifications*²

(2) ASTM E350, *Standard Test Methods for Chemical Analysis of Carbon Steel, Low-Alloy Steel, Silicon Electrical Steel, Ingot Iron, and Wrought Iron*

(3) ASTM E1032, *Standard Test Method for Radiographic Examination of Weldments*

¹ ANSI Z49.1 is published by the American Welding Society, 8669 Doral Blvd., Doral, FL 33166.

² ASTM standards are published by ASTM International, 100 Barr Harbor Drive, West Conshohocken, PA 19428-2959.

(4) AWS A1.1, *Metric Practice Guide for the Welding Industry*³

(5) AWS A4.3, *Standard Methods for Determination of the Diffusible Hydrogen Content of Martensitic, Bainitic, and Ferritic Steel Weld Metal Produced by Arc Welding*

(6) AWS A4.4M, *Standard Procedure for Determination of Moisture Content of Welding Fluxes and Welding Electrode Flux Coverings*

(7) AWS A5.01M/A5.01 (ISO 14344 MOD), *Procurement Guidelines for Consumables—Welding and Allied Processes—Flux and Gas Shielded Electrical Welding Processes*

(8) AWS B4.0 or B4.0M, *Standard Methods for Mechanical Testing of Welds*

(9) ANSI Z49.1 *Safety in Welding, Cutting, and Allied Processes*

(10) ISO 544, *Welding consumables — Technical delivery conditions for welding filler materials — Type of product, dimensions, tolerances and markings*.⁴

3. Classification

3.1 The welding electrodes covered by the A5.1 specification utilize a system based on U.S. Customary Units to classify the welding electrodes covered according to:

- (1) Type of current (see Table 1)
- (2) Type of covering (see Table 1)
- (3) Welding position (see Table 1)
- (4) Mechanical properties of the weld metal in the as-welded or aged condition (see Tables 2 and 3).

3.1M The welding electrodes covered by the A5.1M specification utilize a system based on International System of Units to classify the welding electrodes covered according to:

- (1) Type of current (see Table 1)
- (2) Type of covering (see Table 1)
- (3) Welding position (see Table 1)
- (4) Mechanical properties of the weld metal in the as-welded or aged condition (see Tables 2 and 3).

3.2 Material classified under one classification shall not be classified under any other classification in one specification, although it may be classified under both specifications, except that E7018M [E4918M] may also be classified as E7018 [E4918] provided the electrode meets all of the requirements of both classifications.

4. Acceptance

Acceptance of the welding electrodes shall be in accordance with the provisions of AWS A5.01M/A5.01 (ISO 14344 MOD).

5. Certification

By affixing the AWS specification and classification designations to the packaging, or the classification to the product, the manufacturer certifies that the product meets the requirements of this specification.⁵

³ AWS standards are published by the American Welding Society, 8669 Doral Blvd., Doral, FL 33166.

⁴ ISO standards are published by the American National Standards Institute, 11 West 42nd Street, New York, NY 10036-8002.

⁵ See Clause A4 for further information concerning certification and the testing called for to meet this requirement.

Table 1
Electrode Classification

AWS Classification		Type of Covering	Welding Position ^a	Type of Current ^b
A5.1	A5.1M			
E6010	E4310	High cellulose sodium	F, V, OH, H	dcep
E6011	E4311	High cellulose potassium	F, V, OH, H	ac or dcep
E6012	E4312	High titania sodium	F, V, OH, H	ac or dcen
E6013	E4313	High titania potassium	F, V, OH, H	ac, dcep, or dcen
E6018 ^c	E4318 ^c	Low-hydrogen potassium, iron powder	F, V, OH, H	ac or dcep
E6019	E4319	Iron oxide titania potassium	F, V, OH, H	ac, dcep, or dcen
E6020	E4320	High iron oxide	H-fillet F	ac or dcen ac, dcep, or dcen
E6022 ^d	E4322 ^d	High iron oxide	F, H-fillet	ac or dcen
E6027	E4327	High iron oxide, iron powder	H-fillet F	ac or dcen ac, dcep, or dcen
E7014	E4914	Iron powder, titania	F, V, OH, H	ac, dcep, or dcen
E7015	E4915	Low-hydrogen sodium	F, V, OH, H	dcep
E7016 ^c	E4916 ^c	Low-hydrogen potassium	F, V, OH, H	ac or dcep
E7018 ^c	E4918 ^c	Low-hydrogen potassium, iron powder	F, V, OH, H	ac or dcep
E7018M	E4918M	Low-hydrogen iron powder	F, V, OH, H	dcep
E7024 ^c	E4924 ^c	Iron power, titania	H-fillet, F	ac, dcep, or dcen
E7027	E4927	High iron oxide, iron powder	H-fillet F	ac or dcen ac, dcep, or dcen
E7028 ^c	E4928 ^c	Low-hydrogen potassium, iron powder	H-fillet, F	ac or dcep
E7048	E4948	Low-hydrogen potassium, iron powder	F, OH, H, V-down	ac or dcep

^a The abbreviations, F, H, H-fillet, V, V-down, and OH indicate the welding positions as follows: F = Flat, H = Horizontal, H-fillet = Horizontal fillet, V = Vertical, progression upwards (for electrodes 3/16 in [5.0 mm] and under, except 5/32 in [4.0 mm] and under for classifications E6018 [E4318], E7014 [E4914], E7015 [E4915], E7016 [E4916], E7018 [E4918], E7018M [E4918M], E7048 [E4948]). V-down = Vertical, progression downwards (for electrodes 3/16 in [5.0 mm] and under, except 5/32 in [4.0 mm] and under for classifications E6018 [E4318], E7014 [E4914], E7015 [E4915], E7016 [E4916], E7018 [E4918], E7018M [E4918M], E7048 [E4948]), OH = Overhead (for electrodes 3/16 in [5.0 mm] and under, except 5/32 in [4.0 mm] and under for classifications E6018 [E4318], E7014 [E4914], E7015 [E4915], E7016 [E4916], E7018 [E4918], E7018M [E4918M], E7048 [E4948]).

^b The term “dcep” refers to direct current electrode positive (dc, reverse polarity). The term “dcen” refers to direct current electrode negative (dc, straight polarity).

^c Electrodes with supplemental elongation, notch toughness, absorbed moisture, and diffusible hydrogen requirements may be further identified as shown in Tables 2, 3, 10, and 11.

^d Electrodes of the E6022 [E4322] classification are intended for single-pass welds only.

6. Rounding-Off Procedure

For purposes of determining compliance with the requirements of this standard, the actual test values obtained shall be subjected to the rounding-off rules of ASTM E29 or ISO 80000-1, Annex B, Rule A (the results are the same). If the measured values are obtained by equipment calibrated in units other than those of the specified limit, the measured values shall be converted to the units of the specified limit before rounding off. If an average value is to be compared to the specified limit, rounding off shall be done only after calculating the average. An observed or calculated value shall be rounded to the nearest 1000 psi (1 ksi) for tensile and yield strength for A5.1, or to the nearest 10 MPa for tensile and yield strength for A5.1M, and to the nearest unit in the last right-hand place of figures used in expressing the limiting values for other quantities. The rounded-off results shall fulfill the requirements for the classification under test.

Table 2
Tension Test Requirements^{a, b, c}

AWS Classification		Tensile Strength		Yield Strength at 0.2% Offset		Elongation
A5.1	A5.1M	A5.1 (ksi)	A5.1M (MPa)	A5.1 (ksi)	A5.1M (MPa)	Percentage in 4x Diameter Length
E6010	E4310	60	430	48	330	22
E6011	E4311	60	430	48	330	22
E6012	E4312	60	430	48	330	17
E6013	E4313	60	430	48	330	17
E6018	E4318	60	430	48	330	22
E6019	E4319	60	430	48	330	22
E6020	E4320	60	430	48	330	22
E6022 ^d	E4322 ^d	60	430	Not Specified		Not Specified
E6027	E4327	60	430	48	330	22
E7014	E4914	70	490	58	400	17
E7015	E4915	70	490	58	400	22
E7016	E4916	70	490	58	400	22
E7018	E4918	70	490	58	400	22
E7024	E4924	70	490	58	400	17 ^e
E7027	E4927	70	490	58	400	22
E7028	E4928	70	490	58	400	22
E7048	E4948	70	490	58	400	22
E7018M	E4918M	Note f	Note f	53–72 ^g	370–500 ^g	24

^a See Table 4 for sizes to be tested.

^b Requirements are in the as-welded condition with aging as specified in 12.2.

^c Single values are minimum.

^d A transverse tension test, as specified in 12.5 and a longitudinal guided bend test, as specified in Clause 13 are required.

^e Weld metal from electrodes identified as E7024-1 [E4924-1] shall have elongation of 22% minimum.

^f Tensile strength of this weld metal is a nominal 70 ksi [490 MPa].

^g For 3/32 in [2.4 mm] electrodes, the maximum yield strength shall be 77 ksi [530 MPa].

Part B

Tests, Procedures, and Requirements

7. Summary of Tests

The tests required for each classification are specified in Table 4. The purpose of these tests is to determine the chemical composition, mechanical properties, and soundness of the weld metal, moisture content of the low-hydrogen electrode covering, and the usability of the electrode. The base metal for the weld test assemblies, the welding and testing procedures to be employed, and the results required are given in Clauses 9 through 18. The supplemental tests for absorbed moisture, in Clause 17, and diffusible hydrogen, in Clause 18, are not required for classification of the low-hydrogen electrodes, except for E7018M [E4918M], where these are required (see notes i and m of Table 4).

8. Retest

If the results of any test fail to meet the requirement, that test shall be repeated twice. The results of both retests shall meet the requirement. Specimens for retest may be taken from the original test assembly or from a new test assembly. For chemical analysis, retest need be only for those specific elements that failed to meet the test requirement. If the results of one or both retests fail to meet the requirement, the material under test shall be considered as not meeting the requirements of this specification for that classification.

Table 3
Charpy V-Notch Impact Requirements

AWS Classification		Limits for 3 out of 5 Specimens ^a	
A5.1	A5.1M	Average, Min.	Single Value, Min.
E6010, E6011, E6018 E6027, E7015, E7016 ^b , E7018 ^b , E7027, E7048	E4310, E4311, E4318 E4327, E4915, E4916 ^b , E4918 ^b , E4927, E4948	20 ft-lbf at –20°F [27 J at –30°C]	15 ft-lbf at –20°F [20 J at –30°C]
E6019 E7028	E4319 E4928	20 ft-lbf at 0°F [27 J at –20°C]	15 ft-lbf at 0°F [20 J at –20°C]
E6012, E6013, E6020, E6022, E7014, E7024 ^b	E4312, E4313 E4320, E4322 E4914, E4924 ^b	Not Specified	Not Specified

AWS Classification		Limits for 5 out of 5 Specimens ^c	
A5.1	A5.1M	Average, Min.	Single Value, Min.
E7018M	E4918M	50 ft-lbf at –20°F [67 J at –30°C]	40 ft-lbf at –20°F [54 J at –30°C]

^a Both the highest and lowest test values obtained shall be disregarded in computing the average. Two of these remaining three values shall equal or exceed 20 ft-lbf [27 J].

^b Electrodes with the following optional supplemental designations shall meet the lower temperature impact requirements specified below:

AWS Classification		Electrode Designation		Charpy V-Notch Impact Requirements, Limits for 3 out of 5 specimens (Refer to Note a above)	
A5.1	A5.1M	A5.1	A5.1M	Average, Min.	Single Value, Min.
E7016 E7018	E4916 E4918	E7016-1 E7018-1	E4916-1 E4918-1	20 ft-lbf at –50°F [27 J at –45°C]	15 ft-lbf at –50°F [20 J at –45°C]
E7024	E4924	E7024-1	E4924-1	20 ft-lbf at 0°F [27 J at –20°C]	15 ft-lbf at 0°F [20 J at –20°C]

^c All five values obtained shall be used in computing the average. Four of the five values shall equal, or exceed, 50 ft-lbf [67 J].

In the event that, during preparation or after completion of any test, it is clearly determined that prescribed or proper procedures were not followed in preparing the weld test assembly or test specimen(s) or in conducting the test, the test shall be considered invalid, without regard to whether the test was actually completed or whether test results met, or failed to meet, the requirement. That test shall be repeated, following proper prescribed procedures. In this case, the requirement for doubling the number of test specimens does not apply.

9. Weld Test Assemblies

9.1 One or more of the following five weld test assemblies are required:

- (1) The weld pad in Figure 1 for chemical analysis of the weld metal
- (2) The groove weld in Figure 2 for mechanical properties and soundness of weld metal made with all electrode classifications except E6022 [E4322] and E7018M [E4918M]
- (3) The fillet weld in Figure 3 for the usability of the electrode

**Table 4
Required Tests^a**

AWS Classification		Current and Polarity ^a	Electrode Size		Welding Position for Test Assembly ^b				
A5.1	A5.1M		A5.1 (in)	A5.1M (mm)	Chemical ^c Analysis	Radiographic Test ^d All-Weld-Metal Tension Test ^e	Impact Test ^f	Fillet Weld Test ^g	Moisture Test ⁱ
E6010	E4310	dcep	3/32, 1/8	2.4, 2.5, 3.2	NR	NR	NR	NR	NR
			5/32, 3/16	4.0, 4.8, 5.0	F	F	F	V & OH	NR
			7/32	5.6	NR	NR	NR	NR	NR
			1/4	6.0, 6.4	F	F	F	H-fillet	NR
			5/16	8.0	NR	F	NR	NR	NR
E6011	E4311	ac and dcep	3/32, 1/8	2.4, 2.5, 3.2	NR	NR	NR	NR	NR
			5/32, 3/16	4.0, 4.8, 5.0	F	F	F	V & OH	NR
			7/32	5.6	NR	NR	NR	NR	NR
			1/4	6.0, 6.4	F	F	F	H-fillet	NR
			5/16	8.0	NR	F	NR	NR	NR
E6012	E4312	ac and dcen	1/16 to 1/8 inc.	1.6 to 3.2 inc.	NR	NR	NR	NR	NR
			5/32, 3/16	4.0, 4.8, 5.0	F	F ^h	NR	V & OH	NR
			7/32	5.6	NR	NR	NR	NR	NR
			1/4, 5/16	6.0, 6.4, 8.0	F	F ^h	NR	H-fillet	NR
E6013	E4313	ac, dcep, and dcen	1/16 to 1/8 inc.	1.6 to 3.2 inc.	NR	NR	NR	NR	NR
			5/32, 3/16	4.0, 4.8, 5.0	F	F ^k	NR	V & OH	NR
			7/32	5.6	NR	NR	NR	NR	NR
			1/4, 5/16	6.0, 6.4, 8.0	F	F ^k	NR	H-fillet	NR
E6018	E4318	ac and dcep	3/32, 1/8	2.4, 2.5, 3.2	NR	NR	NR	NR	NR
			5/32	4.0	F	F	F	V & OH	Reqd.
			3/16	4.8, 5.0	NR	F	F	H-fillet	NR
			7/32	5.6	NR	NR	NR	NR	NR
			1/4	6.0, 6.4	F	F	F	H-fillet	Reqd.
5/16	8.0	NR	F	NR	NR	NR	NR		
E6019	E4319	ac, dcep, and dcen	5/64 to 1/8 inc.	2.0 to 3.2 inc.	NR	NR	NR	NR	NR
			5/32, 3/16	4.0, 4.8, 5.0	F	F ^k	F ^l	V & OH	NR
			7/32	5.6	NR	NR	NR	NR	NR
			1/4, 5/16	6.0, 6.4, 8.0	F	F ^k	F ^l	H-fillet	NR
E6020	E4320	For H-fillet, ac and dcen; For flat position, ac, dcep, and dcen	1/8	3.2	NR	NR	NR	NR	NR
			5/32, 3/16	4.0, 4.8, 5.0	F	F ^k	NR	H-fillet	NR
			7/32	5.6	NR	NR	NR	NR	NR
			1/4	6.0, 6.4	F	F ^k	NR	H-fillet	NR
			5/16	8.0	NR	F ^k	NR	NR	NR
E6022	E4322	ac and dcen	1/8	3.2	NR	F ^{h,j}	NR	NR	NR
			5/32 to 7/32 inc.	4.0 to 5.6 inc.	NR	F ^{h,j}	NR	NR	NR
E6027	E4327	For H-fillet, ac and dcen; For flat position, ac, dcep, and dcen	1/8	3.2	NR	NR	NR	NR	NR
			5/32, 3/16	4.0, 4.8, 5.0	F	F ^{k,1}	F ^k	H-fillet	NR
			7/32	5.6	NR	NR	NR	NR	NR
			1/4	6.0, 6.4	F	F ^{k,1}	F ^k	H-fillet	NR
			5/16	8.0	NR	F ^{k,1}	NR	NR	NR
E7014	E4914	ac, dcep, and dcen	3/32, 1/8	2.4, 2.5, 3.2	NR	NR	NR	NR	NR
			5/32	4.0	F ^k	F ^k	NR	V & OH	NR
			3/16	4.8, 5.0	NR	F ^k	NR	H-fillet	NR
			7/32	5.6	NR	NR	NR	NR	NR
			1/4	6.0, 6.4	F ^k	F ^k	NR	H-fillet	NR
5/16	8.0	NR	F ^k	NR	H-fillet	NR			

(Continued)

Table 4 (Continued)
Required Tests^a

AWS Classification		Current and Polarity ^a	Electrode Size		Welding Position for Test Assembly ^b				
A5.1	A5.1M		A5.1 (in)	A5.1M (mm)	Chemical ^c Analysis	Radiographic Test ^d All-Weld-Metal Tension Test ^e	Impact Test ^f	Fillet Weld Test ^g	Moisture Test ⁱ
E7015	E4915	dcep	3/32, 1/8	2.4, 2.5, 3.2	NR	NR	NR	NR	NR
			5/32	4.0	F	F	F	V & OH	Reqd.
			3/16	4.8, 5.0	NR	F	F	H-fillet	NR
			7/32	5.6	NR	NR	NR	NR	NR
			1/4	6.0, 6.4	F	F	F	H-fillet	Reqd.
5/16	8.0	NR	F	NR	NR	NR			
E7016	E4916	ac and dcep	3/32, 1/8	2.4, 2.5, 3.2	NR	NR	NR	NR	NR
			5/32	4.0	F	F	F	V & OH	Reqd.
			3/16	4.8, 5.0	NR	F	F	H-fillet	NR
			7/32	5.6	NR	NR	NR	NR	NR
			1/4	6.0, 6.4	F	F	F	H-fillet	Reqd.
5/16	8.0	NR	F	NR	NR	NR			
E7018	E4918	ac and dcep	3/32, 1/8	2.4, 2.5, 3.2	NR	NR	NR	NR	NR
			5/32	4.0	F	F	F	V & OH	Reqd.
			3/16	4.8, 5.0	NR	F	F	H-fillet	NR
			7/32	5.6	NR	NR	NR	NR	NR
			1/4	6.0, 6.4	F	F	F	H-fillet	Reqd.
5/16	8.0	NR	F	NR	NR	NR			
E7018M ^m	E4918M ^m	dcep	3/32 to 5/32 inc.	2.4 to 4.0 inc.	F	V	V	NR	Reqd.
			3/16 to 5/16 inc.	4.8 to 8.0 inc.	F	F	F	NR	Reqd.
E7024	E4924	ac, dcep, and dcen	3/32, 1/8	2.4, 2.5, 3.2	NR	NR	NR ⁿ	NR	NR
			5/32	4.0	F ^l	F ^{k,1}	F ⁿ	H-fillet	NR
			3/16	4.8, 5.0	NR	F ^{k,1}	F ⁿ	H-fillet	NR
			7/32	5.6	NR	NR	NR ⁿ	NR	NR
			1/4	6.0, 6.4	F ^l	F ^{k,1}	F ⁿ	H-fillet	NR
5/16	8.0	NR	F ^{k,1}	NR ⁿ	NR	NR			
E7027	E4927	For H-fillet, ac and dcen For flat position, ac, dcep, and dcen	1/8	3.2	NR	NR	NR	NR	NR
			5/32	4.0	F ^l	F ^{k,1}	F ^l	H-fillet	NR
			3/16	4.8, 5.0	NR	F ^{k,1}	F ^l	H-fillet	NR
			7/32	5.6	NR	NR	NR	NR	NR
			1/4	6.0, 6.4	F ^l	F ^{k,1}	F ^l	H-fillet	NR
5/16	8.0	NR	F ^{k,1}	NR	NR	NR			
E7028	E4928	ac and dcep	1/8	3.2	NR	NR	NR	NR	NR
			5/32	4.0	F	F ^l	F	H-fillet	Reqd.
			3/16	4.8, 5.0	NR	F ^l	F	H-fillet	NR
			7/32	5.6	NR	NR	NR	NR	NR
			1/4	6.0, 6.4	F	F ^l	F	H-fillet	Reqd.
5/16	8.0	NR	F ^l	NR	NR	NR			
E7048	E4948	ac and dcep	1/8	3.2	NR	NR	NR	NR	NR
			5/32	4.0	F	F	F	V-down & OH	Reqd.
			3/16	4.8, 5.0	NR	F	F	V-down & H-fillet	NR

(Continued)

Table 4 (Continued)
Required Tests^a

^a NR means “not required.” The abbreviations, F, H-fillet, V-down, V, and OH are defined in Note a of Table 1. The terms “dcep” and “dcen,” are defined in Note b of Table 1.

^b Standard electrode sizes not requiring this specific test can be classified provided at least two other sizes of that classification have passed the tests required for them, or the size to be classified meets specification requirements by having been tested in accordance with Figures 1, 2, and 3 and Table 6.

^c See Clause 10.

^d See Clause 11.

^e See Clause 12.

^f See Clause 14.

^g See Clause 15.

^h A radiographic test is not required for this classification.

ⁱ The moisture test given in Clause 16 is the required test for moisture content of the covering. In Clauses 17 and 18 are supplemental tests required only when their corresponding optional supplemental designators are to be used with the classification designators.

^j An all-weld-metal tension test is not required for E6022 [E4322] electrodes. Instead, a transverse tension test (see 12.5) and a longitudinal guided bend test (see Clause 13) are required for classification of 5/32 in, 3/16 in, and 7/32 in [4.0 mm, 5.0 mm, and 6.0 mm] E6022 [E4322] electrodes.

^k When dcep and dcen are shown, only dcen need be tested.

^l Electrodes longer than 18 in [450 mm] will require a double length test assembly in accordance with Note 1 of Figure 2, to ensure uniformity of the entire electrode.

^m Tests in Clause 17, and in Clause 18, are required for all sizes of E7018M [E4918M].

ⁿ Electrodes identified as E7024-1 [E4924-1] shall be impact tested (see Note b of Table 3).

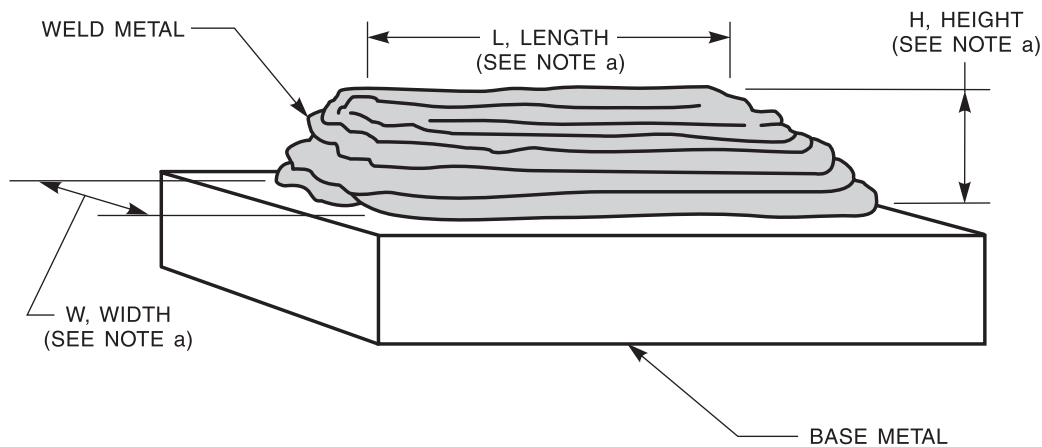

^a The minimum completed pad size shall be at least four layers in height (H) with length (L) and width (W) sufficient to perform analysis. The sample for analysis shall be taken at least 1/4 in [6.0 mm] above the original base metal surface.

Notes:

1. Base metal of any convenient size, of any type specified in Table 5, shall be used as the base for the weld pad.
2. The surface of the base metal on which the filler metal is to be deposited shall be clean.
3. The pad shall be welded in the flat position with successive layers to obtain undiluted weld metal.
4. One pad shall be welded for each type of current shown in Table 4 except for those classifications identified by note k in Table 4.
5. The number and size of the beads will vary according to the size of the electrode and the width of the weave, as well as the amperage employed. The width of each weld pass in each weld layer shall be no more than 2-1/2 times the diameter of the core wire.
6. The preheat temperature shall not be less than 60°F [15°C] and the interpass temperature shall not exceed 300°F [150°C].
7. The slag shall be removed after each pass.
8. The test assembly may be quenched in water between passes to control interpass temperature.

Figure 1—Pad for Chemical Analysis of Undiluted Weld Metal

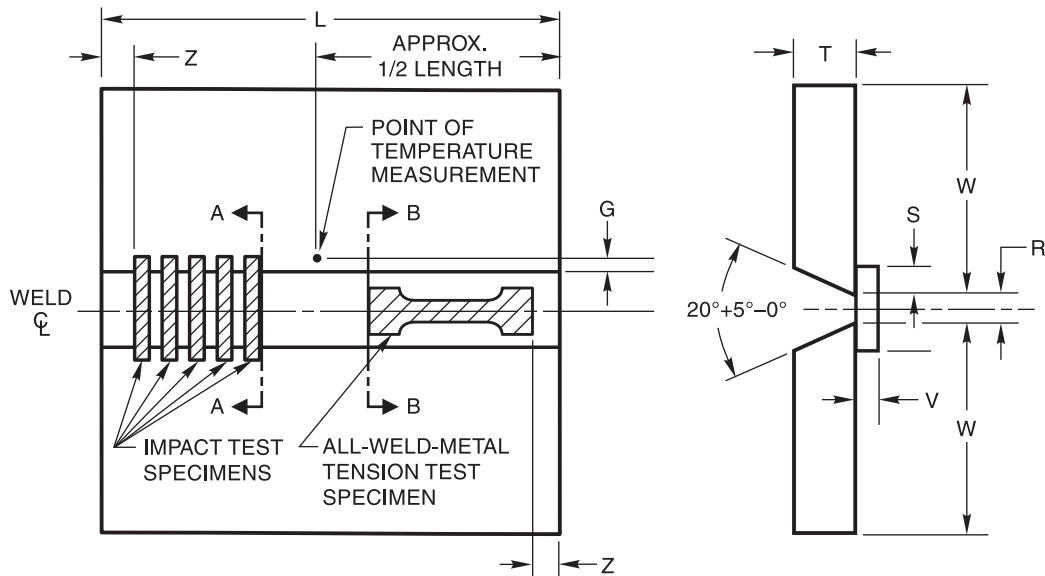

(A) TEST PLATE SHOWING LOCATION OF TEST SPECIMENS

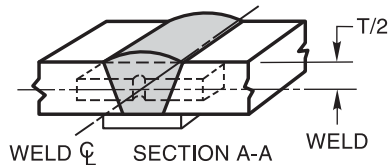

(B) ORIENTATION AND LOCATION OF IMPACT TEST SPECIMEN

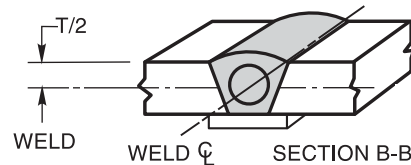

(C) LOCATION OF ALL-WELD-METAL TENSION TEST SPECIMEN

Dimension	Description	A5.1		A5.1M		Electrode Size		Plate Thickness (T)		Root Opening (R)		Passes per Layer	Total Layers
		(in)	(mm)	(in)	(mm)	A5.1 (in)	A5.1M (mm)	A5.1 (in)	A5.1M (mm)				
G	Offset from Groove Edge	1/4-1/2	6-15	3/32	2.5	1/2	12	3/8	10	2	Not Specified		
L	Length, min. (See Note 1)	10	250	1/8	3.2	1/2	12	1/2	13	2	5-7		
S	Strip Overlap, min.	1/4	6	5/32	4.0	3/4	20	5/8	16	2	7-9		
V	Strip Thickness, min.	1/4	6	3/16	5.0	3/4	20	3/4	19	2	6-8		
W	Width, min.	5	125	7/32	6.0	3/4	20	7/8	22	2	6-8		
Z	Discard, min.	1	25	1/4	6.0	1	25	1	25	2	9-11		
				5/16	8.0	1-1/4	30	1-1/8	28	2	10-12		

Notes:

- For electrodes longer than 18 in [450 mm], a 20 in [500 mm] long test assembly shall be welded.
- Base metal shall be as specified in Table 5.
- The surfaces to be welded shall be clean.
- Prior to welding, the assembly may be preset to yield a welded joint sufficiently flat to facilitate removal of the test specimens. As an alternative, restraint or a combination of restraint and presetting may be used to keep the welded joint within 5° of plane. A welded test assembly that is more than 5° out of plane shall be discarded. Straightening of the test assembly is prohibited.
- Welding shall be in the flat position, using each type of current specified in Table 4 except for classifications identified by Note k in Table 4.
- The preheat temperature shall be 225°F [105°C] minimum. The interpass temperature shall not be less than 225°F [105°C] nor more than 350°F [175°C].
- The joint root may be seal welded with 3/32 in or 1/8 in [2.5 mm or 3.2 mm] electrodes using stringer beads.
- In addition to the stops and starts at the ends, each pass shall contain a stop and start in between the ends.
- The completed weld shall be at least flush with the surface of the test plate.

Figure 2—Groove Weld Test Assembly for Mechanical Properties and Soundness of Weld Metal Produced by Using All Electrode Classifications Except E6022 [E4322] and E7018M [E4918M] Electrodes

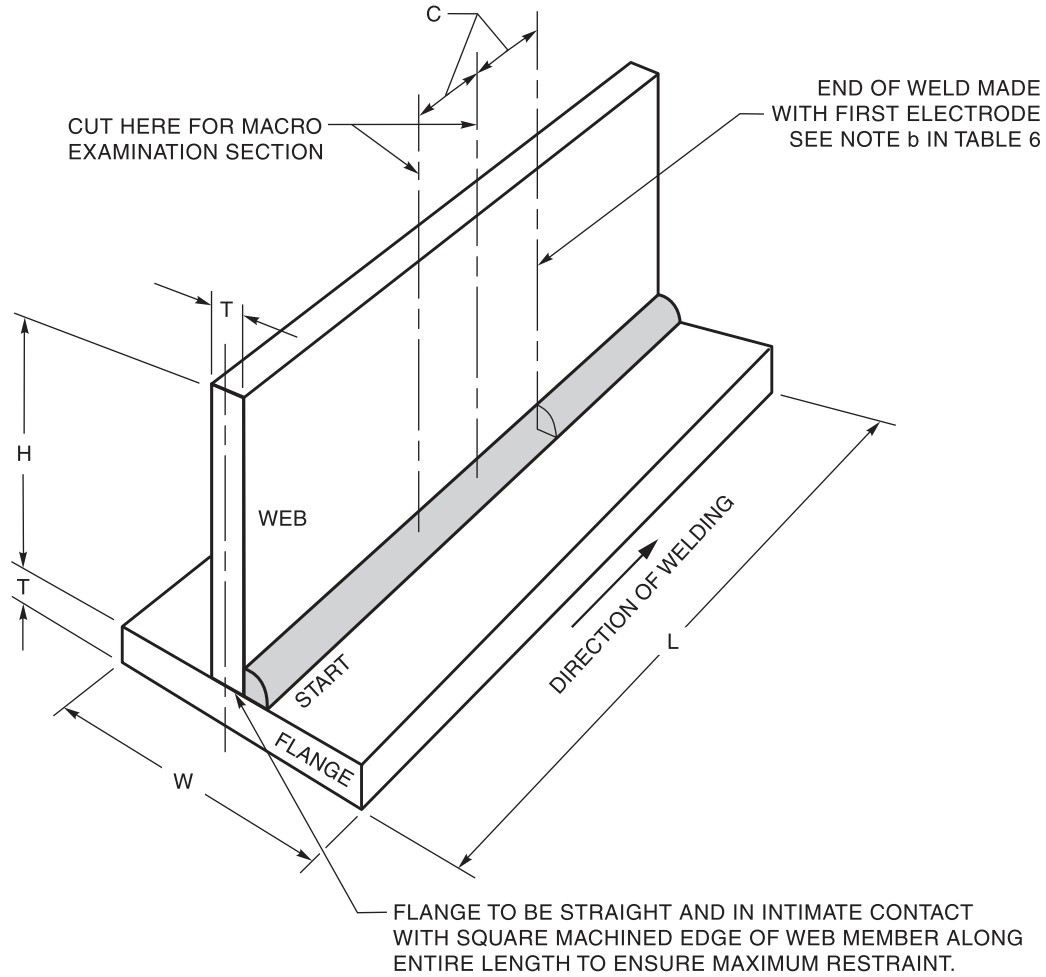

DIMENSIONS	in	mm
C, approx.	1	25
H, min.	3	75
W, min.	3	75
T	See Table 6	
L	See Table 6	

Notes:

1. Base metal shall be as specified in Table 5.
2. The surfaces to be welded shall be clean.
3. An assembly shall be welded in each position specified in Table 6 and shown in Figure 6 using each type of current specified in Table 4.
4. The preheat shall be 60°F [15°C] minimum.
5. A single pass fillet weld shall be made on one side of the joint. The first electrode shall be consumed to a stub length no greater than 2 in [50 mm].
6. Welding in the vertical position shall be upward progression, except the E7048 [E4948] classification where progression shall be downward.
7. Weld cleaning shall be limited to slag chipping, brushing, and needle scaling. Grinding or filing of the weld is prohibited.

Figure 3—Fillet Weld Test Assembly

(4) The groove weld in Figure 4 for transverse tensile and longitudinal bend tests for welds made with the E6022 [E4322] single-pass electrode

(5) The groove weld in Figure 5 for mechanical properties and soundness of weld metal made with the E7018M [E4918M] electrode.

The sample for chemical analysis may be taken from the reduced section of the fractured tension test specimen or from a corresponding location (or any location above it) in the weld metal in the groove weld in Figures 2 or 5, thereby avoiding the need to make the weld pad. In case of dispute, the weld pad shall be the referee method.

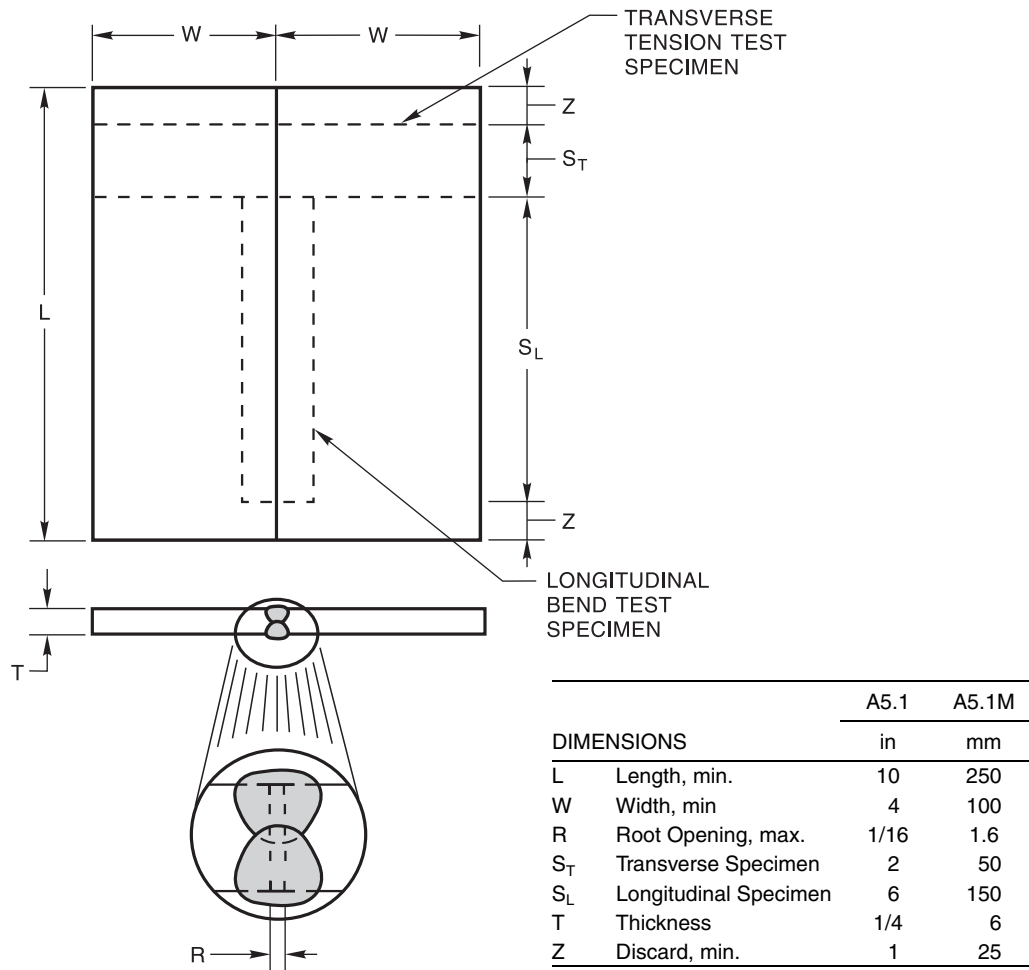

Notes:

1. Base metal shall be as specified in Table 5.
2. The surfaces to be welded shall be clean.
3. Prior to welding, the assembly may be preset to yield a welded joint sufficiently flat to facilitate removal of the test specimens. As an alternative, restraint or a combination of restraint and presetting may be used to keep the welded joint within 5° of plane. A welded test assembly that is more than 5° out of plane shall be discarded. Straightening of the test assembly is prohibited.
4. The assembly shall be welded in the flat position, using the type of current specified in Table 4.
5. The preheat temperature shall be 60°F [15°C] min. The interpass temperature shall not exceed 350°F [180°C].
6. In addition to the stops and starts at the ends, each pass shall contain a stop and start in between the ends.
7. Back gouging may be done to ensure sound weld metal through the entire thickness of test assembly.
8. The completed weld shall be at least flush with the surface of the test plate.

Figure 4—Test Assembly for Transverse Tension and Longitudinal Guided Bend Tests for Welds Made With E6022 [E4322] Electrodes

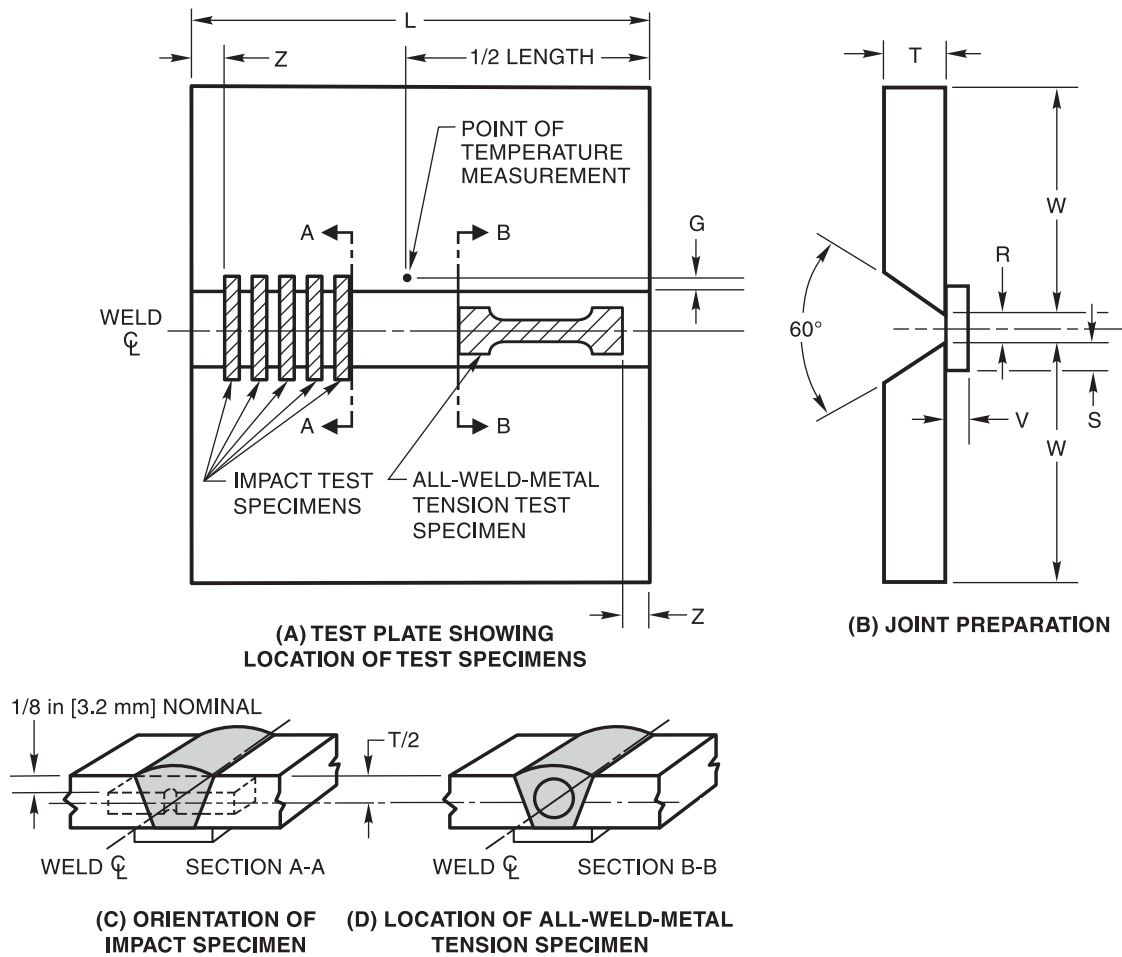

Dimension	Description	A5.1 (in)	A5.1M (mm)
G	Offset from Groove Edge	1/4–1/2	6–15
L	Length, min.	10	250
R	Root Opening, min.	1/4	6
S	Strip Overlap, min.	1/4	6
T	Plate Thickness	3/4	20
V	Strip Thickness, min.	1/4	6
W	Width, min.	5	125
Z	Discard, min.	1	25

Notes:

1. Base metal shall be as specified in Table 5.
2. The surfaces to be welded shall be clean.
3. Prior to welding, the assembly may be preset to yield a welded joint sufficiently flat to facilitate removal of the test specimens. As an alternative, restraint or a combination of restraint and presetting may be used to keep the welded joint within 5° of plane. A welded test assembly that is more than 5° out of plane shall be discarded. Straightening of the test assembly is prohibited.
4. The assembly shall be welded in the vertical position with progression upward for electrodes 5/32 in [4.0 mm] and less in size, and in the flat position for electrodes 3/16 in [5.0 mm] and greater in size, using the type of current specified in Table 4 for the electrode and welding technique recommended by the electrode manufacturer.
5. The preheat temperature and the interpass temperature shall be 200°F to 250°F [90°C to 120°C].
6. The welding heat input shall be 30 kJ/in to 40 kJ/in [1.2 kJ/mm to 1.6 kJ/mm] for the 3/32 in [2.5 mm] size electrodes and 50 kJ/in to 60 kJ/in [2.0 kJ/mm to 2.4 kJ/mm] for the 1/8 in [3.2 mm] size and larger electrodes.
7. In addition to the stops and starts at the ends, each pass shall contain a stop and start in between the ends.
8. The completed weld shall be at least flush with the surface of the test plate. Maximum weld reinforcement shall be 3/16 in [5.0 mm]. Peening of weld beads is not permitted.

Figure 5—Groove Weld Test Assembly for Mechanical Properties and Soundness of Weld Metal Produced by Using E7018M [E4918M] Electrodes

9.2 Preparation of each weld test assembly shall be as prescribed in 9.3 through 9.5. The base metal for each assembly shall be as required in Table 5 and shall meet the requirements of the ASTM specification shown there or an equivalent specification. Electrodes other than low-hydrogen electrodes shall be tested without conditioning.⁶ Low-hydrogen electrodes, if they have not been protected against moisture pickup in storage, shall be held at a temperature within the range 500°F to 800°F [260°C to 430°C] for a minimum of one hour prior to testing. Testing of the assemblies shall be as prescribed in Clauses 10 through 15.

9.3 Weld Pad. A weld pad shall be prepared as specified in Figure 1, except when one of the alternatives in 9.1 (taking the sample from the broken tension test specimen or from a corresponding location—or any location above it—in the weld metal in the groove weld in Figure 2 or 5) is selected. Base metal of any convenient size of the type specified in Table 5 shall be used as the base for the weld pad. The surface of the base metal on which the filler metal is deposited shall be clean. The pad shall be welded in the flat position with multiple layers to obtain undiluted weld metal.

The preheat temperature shall be not less than 60°F [15°C] and the interpass temperature shall not exceed 300°F [150°C]. The slag shall be removed after each pass. The pad may be quenched in water between passes. The dimensions of the completed pad shall be as shown in Figure 1. Testing of this assembly shall be as specified in Clause 10.

9.4 Groove Weld

9.4.1 Mechanical Properties and Soundness. A test assembly shall be prepared and welded as specified in Figure 2 or 5 using base metal of the appropriate type specified in Table 5. Testing of this assembly shall be as specified in Clauses 11, 12, and 14. The assembly shall be tested in the as-welded condition.

9.4.2 Transverse Tension and Longitudinal Bend Tests. A test assembly shall be prepared and welded as specified in Figure 4 using base metal of the appropriate type specified in Table 5. Testing of this assembly shall be as specified in 12.5 through 12.7 and Clause 13. The assembly shall be tested in the as-welded condition.

9.5 Fillet Weld. A test assembly shall be prepared and welded as specified in Table 4 and Figure 3 using base metal of the appropriate type specified in Table 5. The welding positions shall be as specified in Table 6 and Figures 3 and 6 according to the size and classification of electrode. Testing of the assembly shall be as specified in Clause 15.

10. Chemical Analysis

10.1 The sample for analysis shall be taken from weld metal produced with the electrode. The sample shall be taken from a weld pad or the reduced section of the fractured all-weld-metal tension test specimen or from a corresponding location in the groove weld in Figure 2 or 5. Areas where arc starts or craters exist shall be avoided.

The top surface of the pad described in 9.3 and shown in Figure 1 shall be removed and discarded, and a sample for analysis shall be obtained from the underlying metal by any appropriate mechanical means. The sample shall be free of slag and shall be taken at least 1/4 in [6 mm] from the nearest surface of the base metal.

The sample from the reduced section of the fractured tension test specimen or from a corresponding location (or any location above it) in the groove weld in Figure 2 or 5 shall be prepared for analysis by any suitable mechanical means.

10.2 The sample shall be analyzed by accepted analytical methods. The referee method shall be ASTM E350, *Standard Test Methods for Chemical Analysis of Carbon Steel, Low Alloy Steel, Silicon Electrical Steel, Ingot Iron and Wrought Iron*.

10.3 The results of the analysis shall meet the requirements of Table 7 for the classification of the electrode under test.

11. Radiographic Test

11.1 When required in Table 4, the groove weld described in 9.4.1 and shown in Figure 2 or 5 shall be radiographed to evaluate the soundness of the weld metal. In preparation for radiography, the backing shall be removed, and both surfaces of the weld shall be machined or ground smooth. The finished surface of the weld may be flush with the plate or have a reasonably uniform reinforcement not exceeding 3/32 in [2.5 mm]. Both surfaces of the test assembly, in the area of the weld, shall be smooth enough to avoid difficulty in interpreting the radiograph.

⁶Conditioning can be considered to be any preparation or procedure, such as baking the electrode, which the user would not normally practice.

Table 5
Base Metal for Test Assemblies

AWS Classification	Base Metal		
	Type	ASTM Specification ^a	UNS Number ^b
All	Carbon Steel	A131 Grade B	K02102
		A285 Grade A	K01700
		A285 Grade B	K02200
All except E7018M [E4918M]	Carbon Steel	A285 Grade C	K02801
		A283 Grade D	K02702
		A36	K02600
		A29 Grade 1015	G10150
		A29 Grade 1020	G10200

^a Equivalent steel may be used.^b SAE/ASTM Unified Numbering System for Metals and Alloys.

Table 6
Requirements for Preparation of Fillet Weld Test Assemblies

AWS Classification		Electrode Size		Thickness (T) ^a		Length (L), Min. ^b		Welding	Fillet Weld Size	
A5.1	A5.1M	in	mm	in	mm	in	mm	Position	in	mm
E6010 and E6011	E4310 and E4311	3/32	2.4, 2.5	1/8	3	10	250	V & OH	5/32 max.	4.0 max.
		1/8	3.2	3/16	5	12	300	V & OH	3/16 max.	5.0 max.
		5/32	4.0	3/8	10	12	300	V & OH	1/4 max.	6.0 max.
		3/16	4.8, 5.0	3/8	10	12	300	V & OH	5/16 max.	8.0 max.
		7/32	5.6	1/2	12	12 or 16 ^c	300 or 400 ^c	H-fillet	1/4 min.	6.0 min.
		1/4	6.0, 6.4	1/2	12	16	400	H-fillet	1/4 min.	6.0 min.
		5/16	8.0	1/2	12	16	400	H-fillet	1/4 min.	6.0 min.
E6012, E6013, and E6019	E4312, E4313, and E4319	1/16–5/64	1.6–2.0	1/8	3	6	150	V & OH	1/8 max.	3.0 max.
		3/32	2.4, 2.5	1/8	3	10	250	V & OH	1/8 max.	3.0 max.
		1/8	3.2	3/16	5	12	300	V & OH	3/16 max.	5.0 max.
		5/32	4.0	3/8	10	12	300	V & OH	1/4 max.	6.0 max.
		3/16	4.8, 5.0	1/2	12	12	300	V & OH	3/8 max.	10.0 max.
		7/32	5.6	1/2	12	12 or 16 ^c	300 or 400 ^c	H-fillet	1/4 min.	6.0 min.
		1/4	6.0, 6.4	1/2	12	16	400	H-fillet	5/16 min.	8.0 min.
		5/16	8.0	1/2	12	16	400	H-fillet	5/16 min.	8.0 min.
E7014	E4914	3/32	2.4, 2.5	1/8	3	12	300	V & OH	5/32 max.	4.0 max.
		1/8	3.2	3/16	5	12	300	V & OH	3/16 max.	5.0 max.
		5/32	4.0	3/8	10	12	300	V & OH	5/16 max.	8.0 max.
		3/16	4.8, 5.0	3/8	10	12	300	H-fillet	1/4 min.	6.0 min.
		7/32	5.6	3/8	10	12 or 16 ^c	300 or 400 ^c	H-fillet	1/4 min.	6.0 min.
		1/4	6.0, 6.4	1/2	12	16	400	H-fillet	5/16 min.	8.0 min.
		5/16	8.0	1/2	12	16	400	H-fillet	5/16 min.	8.0 min.
E7015 and E7016	E4915 and E4916	3/32	2.4, 2.5	1/8	3	10	250	V & OH	5/32 max.	4.0 max.
		1/8	3.2	1/4	6	12	300	V & OH	3/16 max.	5.0 max.
		5/32	4.0	3/8	10	12	300	V & OH	5/16 max.	8.0 max.
		3/16	4.8, 5.0	3/8	10	12	300	H-fillet	3/16 min.	5.0 min.
		7/32	5.6	1/2	12	12 or 16 ^c	300 or 400 ^c	H-fillet	1/4 min.	6.0 min.
		1/4	6.0, 6.4	1/2	12	16	400	H-fillet	5/16 min.	8.0 min.
		5/16	8.0	1/2	12	16	400	H-fillet	5/16 min.	8.0 min.

(Continued)

Table 6 (Continued)
Requirements for Preparation of Fillet Weld Test Assemblies

AWS Classification		Electrode Size		Thickness (T) ^a		Length (L), Min. ^b		Welding	Fillet Weld Size	
A5.1	A5.1M	in	mm	in	mm	in	mm	Position	in	mm
E6018 and E7018	E4318 and E4918	3/32	2.4, 2.5	1/8	3	10 or 12 ^d	250 or 300 ^d	V & OH	3/16 max.	5.0 max.
		1/8	3.2	1/4	6	12	300	V & OH	1/4 max.	6.0 max.
		5/32	4.0	3/8	10	12	300	V & OH	5/16 max.	8.0 max.
		3/16	4.8, 5.0	3/8	10	12	300	H-fillet	1/4 min.	6.0 min.
		7/32	5.6	1/2	12	12 or 16 ^c	300 or 400 ^c	H-fillet	1/4 min.	6.0 min.
E6020	E4320	1/4	6.0, 6.4	1/2	12	16	400	H-fillet	5/16 min.	8.0 min.
		5/16	8.0	1/2	12	16	400	H-fillet	5/16 min.	8.0 min.
		1/8	3.2	1/4	6	12	300	H-fillet	1/8 min.	3.0 min.
		5/32	4.0	3/8	10	12	300	H-fillet	5/32 min.	4.0 min.
		3/16	4.8, 5.0	3/8	10	12 or 16 ^c	300 or 400 ^c	H-fillet	3/16 min.	5.0 min.
E6027, E7024, E7027, and E7028	E4327, E4924, E4927, and E4928	7/32	5.6	1/2	12	16	400	H-fillet	1/4 min.	6.0 min.
		1/4	6.0, 6.4	1/2	12	16	400	H-fillet	5/16 min.	8.0 min.
		5/16	8.0	1/2	12	16	400	H-fillet	5/16 min.	8.0 min.
		3/32 ^e	2.4, 2.5 ^e	1/4	6	10	250	H-fillet	5/32 min.	4.0 min.
		1/8	3.2	1/4	6	12	300	H-fillet	5/32 min.	4.0 min.
E7048	E4948	5/32	4.0	3/8	10	12	300	V-down & OH	1/4 max.	6.0 max.
		3/16	4.8, 5.0	3/8	10	12 or 16	300 or 400	V-down & OH	5/16 max.	8.0 max.
		5/32	4.0	3/8	10	12	300	H-fillet & V-down	5/16 max.	8.0 max.
		3/16	4.8, 5.0	3/8	10	12 or 16	300 or 400	H-fillet & V-down	1/4 min.	6.0 max.
		5/32	4.0	3/8	10	12	300	H-fillet & V-down	5/16 max.	8.0 max.

^a See Figure 3. Any classification test can be conducted with either USC or SI thickness plate.

^b When the end of the bead with the first electrode will be less than 4 in [100 mm] from the end of the test assembly, a starting tab or a longer test assembly shall be used.

^c For 14 in [350 mm] electrodes, the minimum length of the test assembly shall be 12 in [300 mm]; for 18 in [450 mm] electrodes, the minimum length of the test assembly shall be 16 in [400 mm].

^d For 12 in [300 mm] electrodes, the minimum length of the test assembly shall be 10 in [250 mm]; for 14 in [350 mm] electrodes, the minimum length of the test assembly shall be 12 in [300 mm].

^e E7024 only.

^f For 18 in [450 mm] electrodes, the minimum length of the test assembly shall be 16 in [400 mm]; for 28 in [700 mm] electrodes, the minimum length of the test assembly shall be 26 in [650 mm].

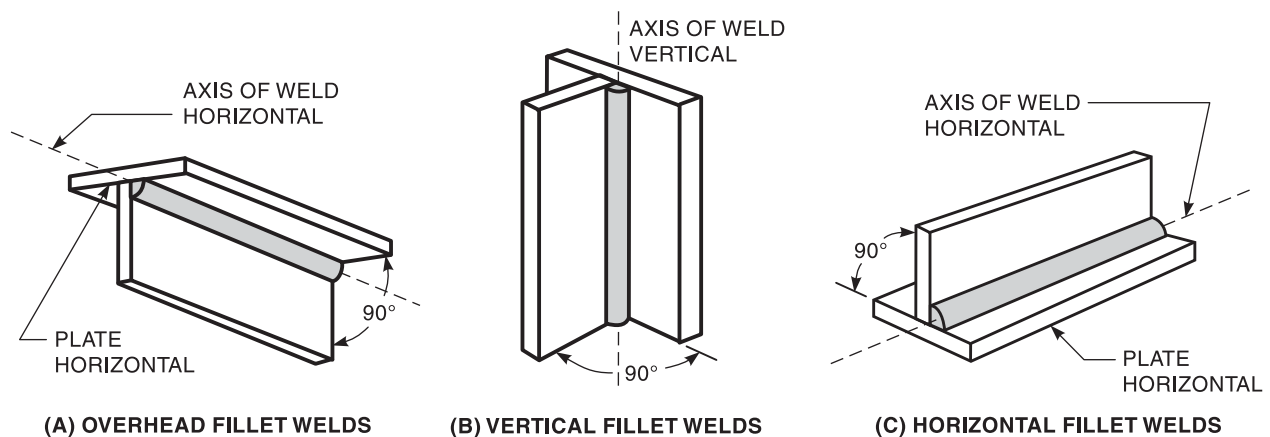

Figure 6—Welding Positions for Fillet Weld Test Assemblies

Table 7
Chemical Composition Requirements for Weld Metal

AWS Classification			Weight Percent ^b									
A5.1	A5.1M	UNS ^a Number	C	Mn	Si	P	S	Ni	Cr	Mo	V	Combined Limit for Mn + Ni + Cr + Mo + V
E6010	E4310	W06010	0.20	1.20	1.00	N.S.	N.S.	0.30	0.20	0.30	0.08	N.S.
E6011	E4311	W06011										
E6012	E4312	W06012										
E6013	E4313	W06013										
E6019	E4319	W06019										
E6020	E4320	W06020										
E6027	E4327	W06027										
E6018	E4318	W06018	0.03	0.60	0.40	0.025	0.015	0.30	0.20	0.30	0.08	N.S.
E7015	E4915	W07015	0.15	1.25	0.90	0.035	0.035	0.30	0.20	0.30	0.08	1.50
E7016	E4916	W07016	0.15	1.60	0.75	0.035	0.035	0.30	0.20	0.30	0.08	1.75
E7018	E4918	W07018	0.15	1.60	0.75	0.035	0.035	0.30	0.20	0.30	0.08	1.75
E7014	E4914	W07014	0.15	1.25	0.90	0.035	0.035	0.30	0.20	0.30	0.08	1.50
E7024	E4924	W07024	0.15	1.25	0.90	0.035	0.035	0.30	0.20	0.30	0.08	1.50
E7027	E4927	W07027	0.15	1.60	0.75	0.035	0.035	0.30	0.20	0.30	0.08	1.75
E7028	E4928	W07028	0.15	1.60	0.90	0.035	0.035	0.30	0.20	0.30	0.08	1.75
E7048	E4948	W07048										
E7018M	E4918M	W07018	0.12	0.40 to 1.60	0.80	0.030	0.020	0.25	0.15	0.35	0.05	N. S.

^a SAE/ASTM Unified Numbering System for Metals and Alloys.

^b Single values are maximum. N. S. means Not Specified.

^c Analysis for boron is required to be reported if intentionally added, or if it is known to be present at levels greater than 0.0010%.

11.2 The weld shall be radiographed in accordance with ASTM E1032. The quality level of inspection shall be 2-2T.

11.3 The soundness of the weld metal meets the requirements of this specification if the radiograph shows:

(1) No cracks, no incomplete fusion or incomplete joint penetration

(2) No slag inclusions longer than 1/4 in [6.0 mm] or 1/3 of the thickness of the weld, whichever is greater, or no groups of slag inclusions in line that have an aggregate length greater than the thickness of the weld in a length 12 times the thickness of the weld, except when the distance between the successive inclusions exceeds 6 times the length of the longest inclusions in the group

(3) No rounded indications in excess of those permitted by the radiographic standards in Figure 7 according to the grade specified in Table 8.

In evaluating the radiograph, 1 in [25 mm] of the weld measured from each end of the assembly shall be disregarded.

11.4 A rounded indication is an indication (on the radiograph) whose length is no more than three times its width. Rounded indications may be circular, elliptical, conical, or irregular in shape, and they may have tails. The size of a rounded indication is the largest dimension of the indication, including any tail that may be present. The indication may be porosity or slag. Indications whose largest dimension does not exceed 1/64 in [0.4 mm] shall be disregarded. Test assemblies with porosity indications larger than the largest rounded indications permitted in the radiographic standards do not meet the requirements of this specification.

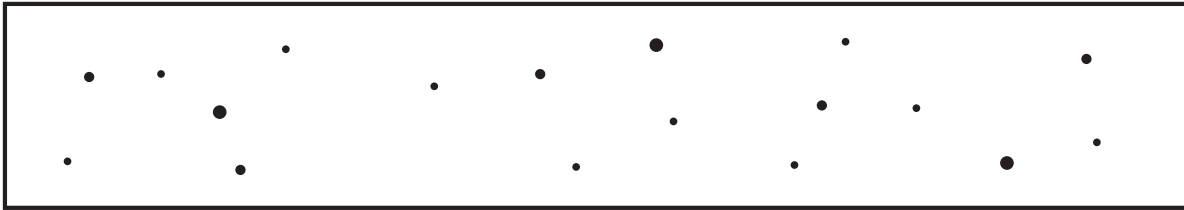

(A) ASSORTED ROUNDED INDICATIONS

SIZE 1/64 in TO 1/16 in [0.4 mm TO 1.6 mm] IN DIAMETER OR IN LENGTH. MAXIMUM NUMBER OF INDICATIONS IN ANY 6 in [150 mm] OF WELD = 18, WITH THE FOLLOWING RESTRICTIONS:

MAXIMUM NUMBER OF LARGE 3/64 in TO 1/16 in [1.2 mm TO 1.6 mm] IN DIAMETER OR IN LENGTH INDICATIONS = 3.

MAXIMUM NUMBER OF MEDIUM 1/32 in TO 3/64 in [0.8 mm TO 1.2 mm] IN DIAMETER OR IN LENGTH INDICATIONS = 5.

MAXIMUM NUMBER OF SMALL 1/64 in TO 1/32 in [0.4 mm TO 0.8 mm] IN DIAMETER OR IN LENGTH INDICATIONS = 10.

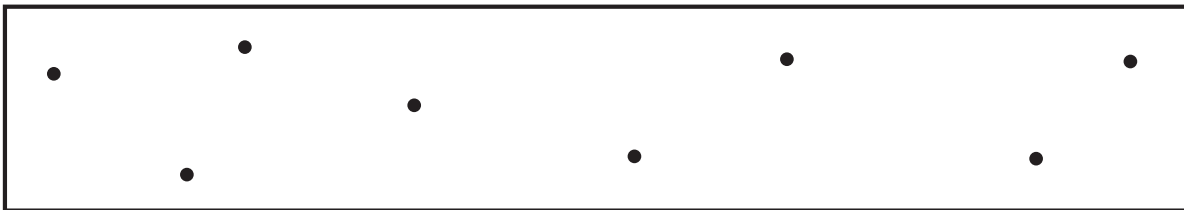

(B) LARGE ROUNDED INDICATIONS

SIZE 3/64 in TO 1/16 in [1.2 mm TO 1.6 mm] IN DIAMETER OR IN LENGTH.

MAXIMUM NUMBER OF INDICATIONS IN ANY 6 in [150 mm] OF WELD = 8.

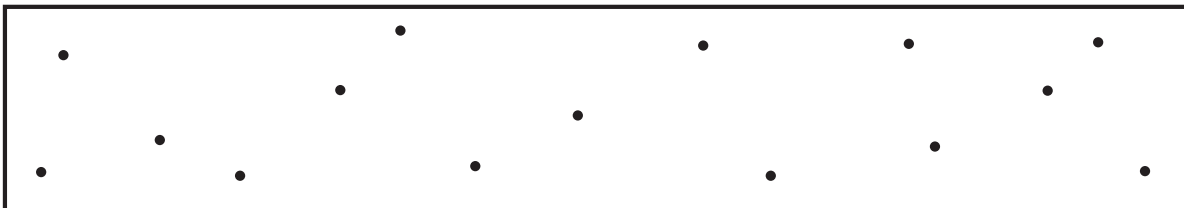

(C) MEDIUM ROUNDED INDICATIONS

SIZE 1/32 in TO 3/64 in [0.8 mm TO 1.2 mm] IN DIAMETER OR IN LENGTH.

MAXIMUM NUMBER OF INDICATIONS IN ANY 6 in [150 mm] OF WELD = 15.

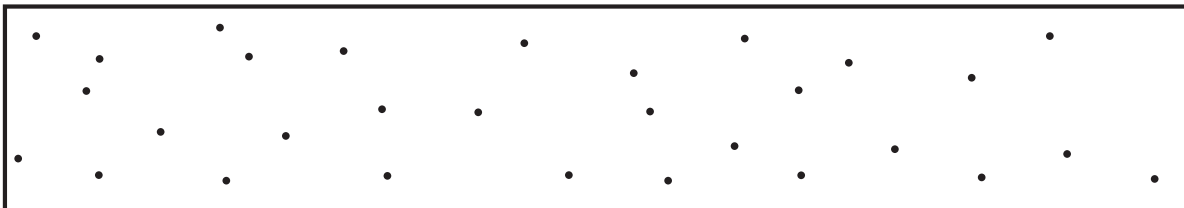

(D) SMALL ROUNDED INDICATIONS

SIZE 1/64 in TO 1/32 in [0.4 mm TO 0.8 mm] IN DIAMETER OR IN LENGTH.

MAXIMUM NUMBER OF INDICATIONS IN ANY 6 in [150 mm] OF WELD = 30.

Notes:

1. In using these standards, the chart which is most representative of the size of the rounded indications present in the test specimen radiograph shall be used for determining conformance to these radiographic standards.
2. Since these are test welds specifically made in the laboratory for classification purposes, the radiographic requirements for these test welds are more rigid than those which may be required for general fabrication.
3. Indications whose largest dimension does not exceed 1/64 in [0.4 mm] shall be disregarded.

Figure 7—Radiographic Acceptance Standards for Rounded Indications (Grade 1)

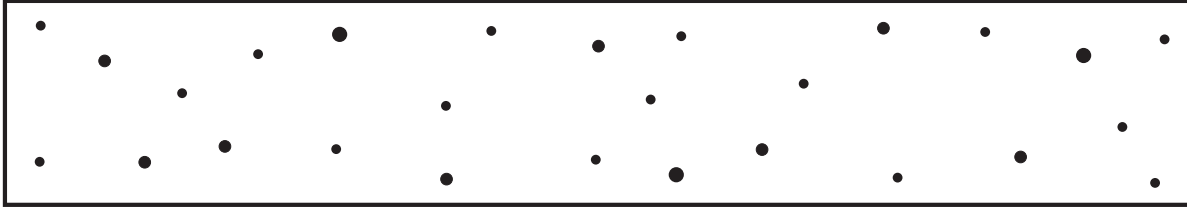

(E) ASSORTED ROUNDED INDICATIONS

SIZE 1/64 in TO 5/64 in [0.4 mm TO 2.0 mm] IN DIAMETER OR IN LENGTH.
MAXIMUM NUMBER OF INDICATIONS IN ANY 6 in [150 mm] OF WELD = 27, WITH THE FOLLOWING RESTRICTIONS:
MAXIMUM NUMBER OF LARGE 1/16 in TO 5/64 in [1.6 mm TO 2.0 mm] IN DIAMETER OR IN LENGTH INDICATIONS = 3.
MAXIMUM NUMBER OF MEDIUM 3/64 in TO 1/16 in [1.2 mm TO 1.6 mm] IN DIAMETER OR IN LENGTH INDICATIONS = 8.
MAXIMUM NUMBER OF SMALL 1/64 in TO 3/64 in [0.4 mm TO 1.2 mm] IN DIAMETER OR IN LENGTH INDICATIONS = 16.

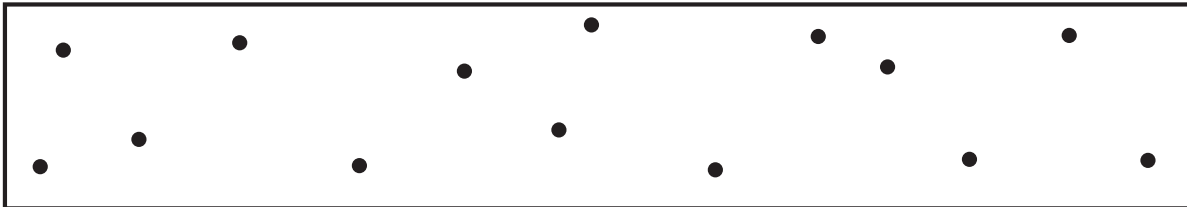

(F) LARGE ROUNDED INDICATIONS

SIZE 1/16 in TO 5/64 in [1.6 mm TO 2.0 mm] IN DIAMETER OR IN LENGTH.
MAXIMUM NUMBER OF INDICATIONS IN ANY 6 in [150 mm] OF WELD = 14.

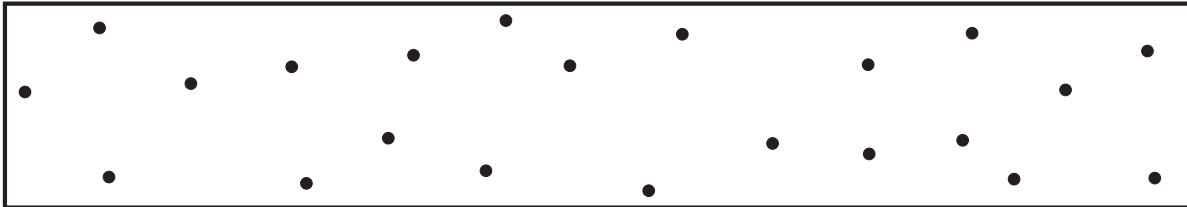

(G) MEDIUM ROUNDED INDICATIONS

SIZE 3/64 in TO 1/16 in [1.2 mm TO 1.6 mm] IN DIAMETER OR IN LENGTH.
MAXIMUM NUMBER OF INDICATIONS IN ANY 6 in [150 mm] OF WELD = 22.

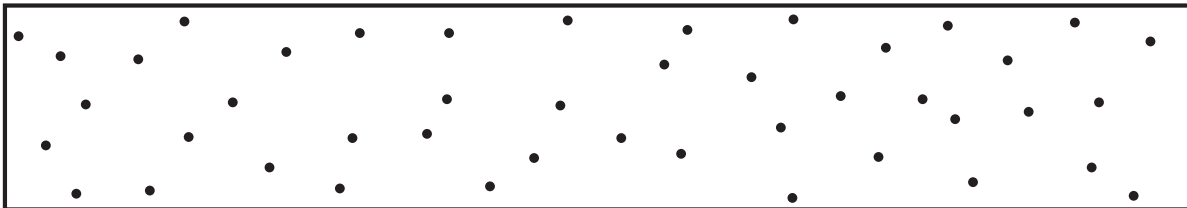

(H) SMALL ROUNDED INDICATIONS

SIZE 1/64 in TO 3/64 in [0.4 mm TO 1.2 mm] IN DIAMETER OR IN LENGTH.
MAXIMUM NUMBER OF INDICATIONS IN ANY 6 in [150 mm] OF WELD = 44.

Notes:

1. In using these standards, the chart which is most representative of the size of the rounded indications present in the test specimen radiograph shall be used for determining conformance to these radiographic standards.
2. Since these are test welds specifically made in the laboratory for classification purposes, the radiographic requirements for these test welds are more rigid than those which may be required for general fabrication.
3. Indications whose largest dimension does not exceed 1/64 in [0.4 mm] shall be disregarded.

Figure 7 (Continued)—Radiographic Acceptance Standards for Rounded Indications (Grade 2)

Table 8
Radiographic Soundness Requirements

AWS Classification		Radiographic Standard ^{a, b}
A5.1	A5.1M	
E6018	E4318	Grade 1
E6019	E4319	
E6020	E4320	
E7015	E4915	
E7016	E4916	
E7018	E4918	
E7018M	E4918M	
E7048	E4948	
E6010	E4310	Grade 2
E6011	E4311	
E6013	E4313	
E6027	E4327	
E7014	E4914	
E7024	E4924	
E7027	E4927	
E7028	E4928	
E6012	E4312	Not Specified
E6022	E4322	

^a See Figure 7.

^b The radiographic soundness obtainable under industrial conditions employed for the various electrode classifications is discussed in A6.10.1 in Annex A.

12. Tension Test

12.1 For all electrodes except E6022 [E4322], one all-weld-metal round tension test specimen as specified in the Tension Test section of AWS B4.0 [AWS B4.0M], *Standard Methods for Mechanical Testing of Welds*, shall be machined from the groove weld described in 9.4.1 and Figure 2 or 5. For a test plate thickness of 1/2 in [12 mm], the all-weld-metal tension test specimen shall have a nominal diameter of 0.250 in [6.5 mm]. For a test plate thickness of 3/4 in [20 mm] or more, the all-weld-metal tension test specimen shall have a nominal diameter of 0.500 in [12.5 mm]. For all plate thicknesses, the gauge length-to-diameter ratio shall be 4:1.

12.2 After machining, but before testing, the specimen for all electrodes except the low hydrogen classifications may be aged at 200°F to 220°F [90°C to 105°C] for up to 48 hours, then allowed to cool to room temperature. Refer to Annex A, A6.3 for a discussion on the purpose of aging.

12.3 The aged and unaged specimens shall be tested in the manner described in the Tension Test section of AWS B4.0 [AWS B4.0M], *Standard Methods for Mechanical Testing of Welds*.

12.4 The results of the tension test shall meet the requirements specified in Table 2.

12.5 For E6022 [E4322], one transverse rectangular tension test specimen as specified in the Tension Test section of AWS B4.0 [AWS B4.0M], *Standard Methods for Mechanical Testing of Welds*, shall be machined from the groove weld described in 9.4.2 and shown in Figure 4. The transverse rectangular tensile specimen shall be a full-thickness specimen machined transverse to the weld with a nominal reduced section width of 1.50 in [38 mm].

13. Bend Test

13.1 One longitudinal face bend specimen, as required in Table 4, shall be machined from the groove weld test assembly described in 9.4.2 and shown in Figure 4. The nominal length of the specimen shall be 6 in [150 mm], the nominal width of the specimen shall be 1.50 in [38 mm], and the nominal thickness shall be 0.25 in [6 mm]. Other dimensions shall be as specified in the Bend Test section of AWS B4.0 [AWS B4.0M], *Standard Methods for Mechanical Testing of Welds*.

13.2 After machining, but before testing, the specimen may be aged at 200°F to 220°F [90°C to 105°C] for up to 48 hours, then allowed to cool to room temperature. Refer to Annex A, A6.3 for a discussion on the purpose of aging.

13.3 The specimen shall be tested in the manner described in the Bend Test section of AWS B4.0 [AWS B4.0M], *Standard Methods for Mechanical Testing of Welds*, by bending it uniformly through 180° over a 3/4 in [19 mm] radius in any suitable jig, as specified in AWS B4.0 [AWS B4.0M]. Positioning of the face bend specimen shall be such that the weld face of the last side welded shall be in tension.

13.4 Each specimen, after bending, shall conform to the 3/4 in [19 mm] radius, with an appropriate allowance for spring-back, and the weld metal shall not contain openings in excess of 1/8 in [3 mm] on the convex surface.

14. Impact Test

14.1 Five full-size Charpy V-notch impact test specimens, as specified in the Fracture Toughness Test section of AWS B4.0 [AWS B4.0M], *Standard Methods for Mechanical Testing of Welds*, shall be machined from the test assembly shown in Figure 2 or 5, for those classifications for which impact testing is required in Table 4. The Charpy V-notch specimens shall have the notched surface and the struck surface parallel with each other within 0.002 in [0.05 mm]. The other two surfaces shall be square with the notched or struck surfaces within ±10 minutes of a degree. The notch shall be smoothly cut by mechanical means and shall be square with the longitudinal edge within 1°.

The geometry of the notch shall be measured on at least one specimen in a set of five specimens. Measurement shall be done at a minimum 50X magnification on either a shadowgraph or a metallograph. The correct location of the notch shall be verified by etching before or after machining.

14.2 The five specimens shall be tested in accordance with the Fracture Toughness Test section of AWS B4.0 [AWS B4.0M]. The test temperature shall be at or below that specified in Table 3 for the classification under test. The actual temperature used shall be listed on the certification documentation when issued.

14.3 In evaluating the test results for all the classifications that require impact testing, except E7018M [E4918M], the lowest and highest values obtained shall be disregarded. Two of the three remaining values shall equal, or exceed, the specified 20 ft·lbf [27 J] energy level. One of the three may be lower, but not lower than 15 ft·lbf [20 J], and the average of the three shall be not less than the required 20 ft·lbf [27 J] energy level.

14.4 In evaluating the results for E7018M [E4918M], all five impact values shall be included. At least four of the five shall equal, or exceed, the specified 50 ft·lbf [67 J] energy level. One of the five may be lower than that, but not lower than 40 ft·lbf [54 J]. The average of the 5 results shall be not less than the required 50 ft·lbf [67 J] energy level.

15. Fillet Weld Test

15.1 The fillet weld test, when required in Table 4, shall be made in accordance with 9.5 and Figure 3. The entire face of the completed fillet weld shall be examined visually. It shall be free of cracks, overlap, slag, and porosity, and shall be substantially free of undercut. An infrequent short undercut up to 1/32 in [0.8 mm] in depth shall be allowed. After the visual examination, a macro examination specimen, approximately 1 in [25 mm] in length, shall be removed as shown in Figure 3. One cross-sectional surface of the specimen shall be polished, etched, and then examined as required in 15.2.

15.2 Scribe lines shall be placed on the prepared surface, as shown in Figure 8, and the fillet weld size, fillet weld leg, and convexity shall be determined to the nearest 1/64 in [0.5 mm] by actual measurement—see Figure 8. These measurements shall meet the requirements of Table 6 with respect to minimum or maximum fillet weld size and the requirements of Table 9 with respect to maximum convexity and maximum difference between fillet weld legs according to the fillet weld size measured.

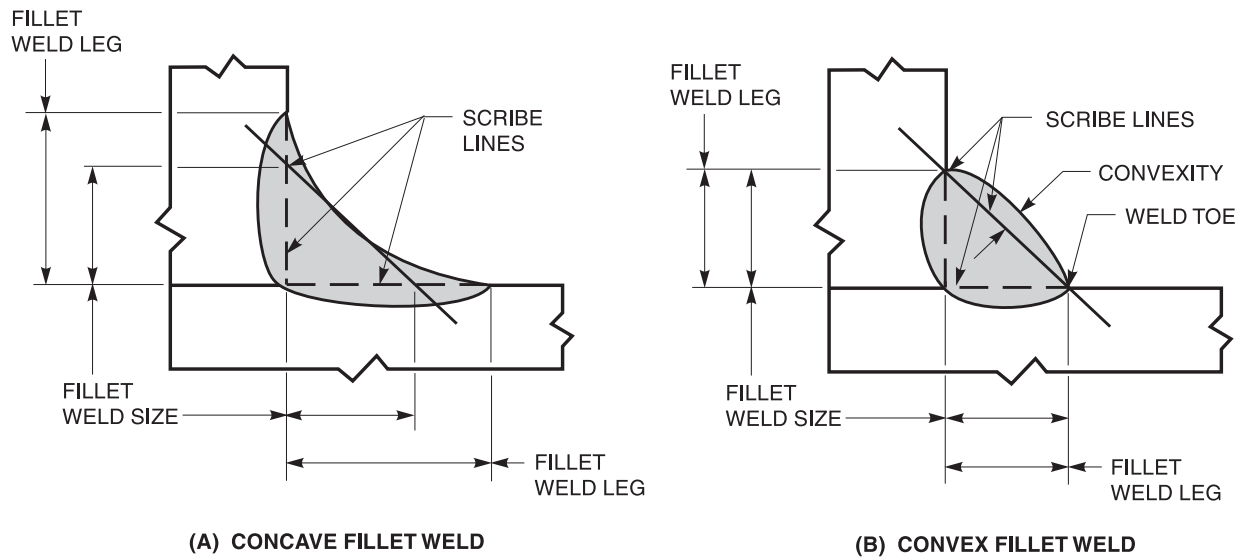

Notes:

1. Fillet weld size is the leg lengths of the largest isosceles right triangle which can be inscribed within the fillet weld cross section.
2. Convexity is the maximum distance from the face of a convex fillet weld perpendicular to a line joining the weld toes.
3. Fillet weld leg is the distance from the joint root to the toe of the fillet weld.

Figure 8—Dimensions of Fillet Welds

Table 9
Dimensional Requirements for
Fillet Weld Usability Test Specimens^a

Measured Fillet Weld Size		Maximum Convexity		Maximum Difference Between Fillet Weld Legs	
in	mm	in	mm	in	mm
1/8	3.0	5/64	2.0	1/32	1.0
9/64	—	5/64	—	3/64	—
5/32	4.0	5/64	2.0	3/64	1.0
11/64	4.5	5/64	2.0	1/16	1.5
3/16	—	5/64	—	1/16	—
13/64	5.0	5/64	2.0	5/64	2.0
7/32	5.5	5/64	2.0	5/64	2.0
15/64	6.0	5/64	2.0	3/32	2.5
1/4	6.5	5/64	2.0	3/32	2.5
17/64	—	3/32	—	7/64	—
9/32	7.0	3/32	2.5	7/64	3.0
19/64	7.5	3/32	2.5	1/8	3.0
5/16	8.0	3/32	2.5	1/8	3.0
21/64	8.5	3/32	2.5	9/64	3.5
11/32	9.0	3/32	2.5	9/64	4.0
23/64	—	3/32	—	5/32	—
3/8	9.5	3/32	2.5	5/32	4.0
or more	or more				

^a All measurements shall be rounded to the nearest 1/64 in [0.5 mm].

15.3 The remaining two sections of the test assembly shall be broken through the fillet weld by a force exerted as shown in Figure 9. When necessary to facilitate fracture through the fillet, one or more of the following procedures may be used:

- (1) A reinforcing bead, as shown in Figure 9A, may be added to each leg of the weld.
- (2) The position of the web on the flange may be changed, as shown in Figure 9B.
- (3) The face of the fillet may be notched, as shown in Figure 9C.

Tests in which the weld metal pulls out of the base metal during bending are invalid tests. Specimens in which this occurs shall be replaced, specimen for specimen, and the test completed. In this case, the doubling of specimens as required for retest in Clause 8, Retest, does not apply.

15.4 The fractured surfaces shall be visually examined without magnification. The fracture surface shall be free of cracks. Incomplete fusion at the weld root shall not be greater than 20% of the total length of the weld. There shall be no continuous length of incomplete fusion greater than 1 in [25 mm] as measured along the weld axis except for electrodes of the E6012 [E4312], E6013 [E4313], and E7014 [E4914] classifications. Fillet welds made with electrodes of these classifications may exhibit incomplete penetration through the entire length. They may also exhibit incomplete fusion which shall at no point exceed 25% of the smaller leg length of the fillet weld.

16. Moisture Test

16.1 The moisture content of the covering of the electrode, when required by Table 4, shall be determined by any suitable method. In case of dispute, the method described in AWS A4.4M, *Standard Procedure for Determination of Moisture Content of Welding Fluxes and Welding Electrode Flux Coverings*, shall be the referee method.

16.2 The electrodes shall be tested without conditioning, unless the manufacturer recommends otherwise. If the electrodes are conditioned, that fact, along with the method used for conditioning, and the time and temperature involved in the conditioning, shall be noted on the test record. The moisture content shall not exceed the limit specified in Table 10, for the classification under test.

17. Absorbed Moisture Test

17.1 In order for a low-hydrogen electrode to be designated as low-moisture-absorbing with the optional supplemental “R” suffix designator or classified as E7018M [E4918M], sufficient electrodes shall be exposed to an environment of 80°F [27°C]/80% relative humidity (RH) for a period of not less than nine hours by any suitable method. In case of dispute, the exposure method described in 17.2 through 17.6 shall be the referee method. The moisture content of the

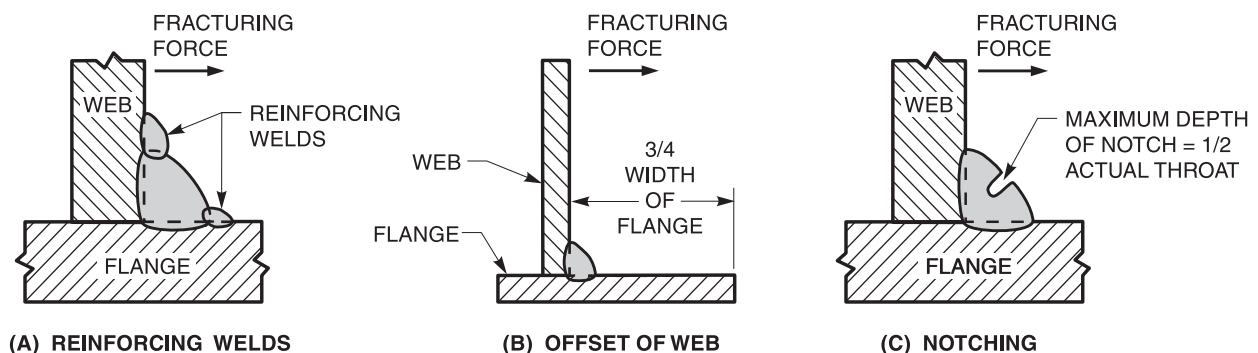

Figure 9—Alternative Methods for Facilitating Fracture of the Fillet Weld

Table 10
Moisture Content Limits for Electrode Coverings

AWS Classification		Electrode Designation		Limit of Moisture Content, % by Wt, Max.	
A5.1	A5.1M	A5.1	A5.1M	As-Received or Conditioned ^a	As-Exposed ^b
E6018	E4318	E6018	E4318		
E7015	E4915	E7015	E4915		
E7016	E4916	E7016	E4916		
		E7016-1	E4916-1		
E7018	E4918	E7018	E4918	0.6	Not Specified
		E7018-1	E4918-1		
E7028	E4928	E7028	E4928		
E7048	E4948	E7048	E4948		
E6018	E4318	E6018R	E4318R		
E7015	E4915	E7015R	E4915R		
E7016	E4916	E7016R	E4916R		
		E7016-1R	E4916-1R		
E7018	E4918	E7018R	E4918R	0.3	0.4
		E7018-1R	E4918-1R		
E7028	E4928	E7028R	E4928R		
E7048	E4948	E7048R	E4948R		
E7018M	E4918M	E7018M	E4918M	0.1	0.4

^a As-received or conditioned electrode coverings shall be tested as specified in Clause 16, Moisture Test.

^b As-exposed electrode coverings shall have been exposed to a moist environment as specified in Clause 17 before being tested as specified in Clause 16.

electrode covering on the low-moisture-absorbing, low-hydrogen electrodes (*for example* E7015R [E4915R], E7016R [E4916R], E7016-1R [E4916-1R], E7018R [E4918R], E7018-1R [E4918-1R], E7018M [E4918M], E7028R [E4928R], E7048R [E4948R]) shall be determined by any suitable method. In case of dispute, the method described in AWS Specification A4.4M, *Standard Procedure for Determination of Moisture Content of Welding Fluxes and Welding Electrode Flux Coverings*, shall be the referee method. The moisture content of the exposed covering shall not exceed the maximum specified moisture content for the designated electrode and classification in Table 10.

17.2 An electrode sample of each size of E7018M [E4918M] or the smallest and the largest sizes of “R” designated electrode shall be exposed. If the electrodes are conditioned prior to exposure, that fact, along with the method used for conditioning, and the time and temperature involved in conditioning, shall be noted on the test record. Conditioning of electrodes after exposure is not permitted.

17.3 The electrode sample shall be exposed in a suitably calibrated and controlled environmental chamber for nine hours minimum at 80°F to 85°F [27°C to 30°C] and 80% to 85% relative humidity.

17.4 The environmental chamber shall meet the following design requirements:

(1) The apparatus shall be an insulated humidifier which produces the temperature of adiabatic saturation through regenerative evaporation or vaporization of water.

(2) The apparatus shall have an average air speed within the envelope of air surrounding the covered electrode of 100 fpm to 325 fpm [0.5 m/s to 1.7 m/s].

(3) The apparatus shall have a drip-free area where the covered electrode up to 18 in [450 mm] in length can be positioned with length as perpendicular as practical to the general air flow.

(4) The apparatus shall have a calibrated means of continuously measuring and recording the dry bulb temperature and either the wet bulb temperature or the differential between the dry bulb and wet bulb temperature over the period of time required.

(5) The apparatus shall have an air speed of at least 900 fpm [4.5 m/s] over the wet bulb sensor unless the wet bulb sensor can be shown to be insensitive to air speed or has a known correction factor that will provide for an adjusted wet bulb reading equal to the temperature of adiabatic saturation.

(6) The apparatus shall have the wet bulb sensor located on the suction side of the fan so that there is an absence of heat radiation on the sensor.

17.5 The exposure procedure shall be as follows:

(1) The electrode sample taken from previously unopened packages, or from a reconditioned lot, shall be heated to a temperature -0° , $+10^{\circ}\text{F}$ [6°C] above the dew point.

(2) The electrode sample shall be loaded into the chamber without delay after the packages are opened.

(3) The electrodes shall be placed in the chamber in a vertical or horizontal position on at least 1 in [25 mm] centers, with the length of the electrode as perpendicular as practical to the general air flow.

(4) Time, temperature, and humidity shall be continuously recorded for the period that the electrodes are in the chamber.

(5) Counting of the exposure time shall start when the required temperature and humidity in the chamber are established.

(6) At the end of the exposure time, the electrodes shall be removed from the chamber and a sample of the electrode covering taken for moisture determination, as specified in Clause 16.

17.6 All of the critical variables which could affect test results have not been identified here. Consequently, the manufacturer shall control such other variables deemed relevant to ensure greater consistency of results.

18. Diffusible Hydrogen Test

18.1 The smallest and largest size of the electrode of each classification to be identified by an optional supplemental diffusible hydrogen designator, and all sizes of E7018M [E4918M], shall be tested according to one of the methods given in AWS A4.3, *Standard Methods for Determination of the Diffusible Hydrogen Content of Martensitic, Bainitic, and Ferritic Steel Weld Metal Produced by Arc Welding*. Based upon the average value of test results which satisfy the requirements of Table 11, the appropriate diffusible hydrogen designator may be added at the end of the classification.

Table 11
Diffusible Hydrogen Limits for Weld Metal^a

AWS Classification		Diffusible Hydrogen Designator	Diffusible Hydrogen Content, Average mL/100g Deposited Metal, Max. ^b
A5.1	A5.1M		
E7018M	E4918M	None	4
E6018	E4318	{ H16 H8 H4	16 8 4
E7015	E4915		
E7016	E4916		
E7018	E4918		
E7028	E4928		
E7048	E4948		

^a Diffusible hydrogen testing in Clause 18, Diffusible Hydrogen Test, is required for E7018M [E4918M]. Diffusible hydrogen testing of other low hydrogen electrodes is only required when the optional diffusible hydrogen designator is added.

^b Some low hydrogen classifications may not meet the H4 and H8 requirements.

18.2 Testing shall be done without conditioning of the electrode, unless the manufacturer recommends otherwise. If the electrodes are conditioned, that fact, along with the method used for conditioning, and the time and temperature involved in the conditioning, shall be noted on the test record.

18.3 For purposes of certifying compliance with diffusible hydrogen requirements, the reference atmospheric condition shall be an absolute humidity of ten (10) grains of moisture/lb [1.43g/kg] of dry air at the time of welding.⁷ The actual atmospheric conditions shall be reported along with the average value for the tests according to AWS A4.3.

18.4 When the absolute humidity equals or exceeds the reference condition at the time of preparation of the test assembly, the test shall be acceptable as demonstrating compliance with the requirements of this specification, provided the actual test results satisfy the diffusible hydrogen requirements for the applicable designator. Likewise, if the actual test results for an electrode meet the requirements for the lower, or lowest hydrogen designator, as specified in Table 11, the electrode also meets the requirements for all higher hydrogen designators in Table 11 without need to retest.

Part C

Manufacture, Identification, and Packaging

19. Method of Manufacture

The electrodes classified according to this specification may be manufactured by any method that will produce electrodes that meet the requirements of this specification.

20. Standard Sizes and Lengths

20.1 Standard sizes (diameter of the core wire) and lengths of electrodes are shown in Table 12.

20.2 The diameter of the core wire shall not vary more than ± 0.002 in [0.05 mm] from the diameter specified. The length shall not vary more than $\pm 1/4$ in [10 mm] from that specified.

⁷ See A8.2 in Annex A.

Table 12
Standard Sizes and Lengths

Core Wire Diameter ^a		Lengths ^{a, b}	
A5.1 (in)	A5.1M ^c (mm)	A5.1 (in)	A5.1M (mm)
1/16	1.6	9	225
5/64	2.0	9 or 12	225 or 300
3/32	—	12 or 14	—
—	2.5	—	300 or 350
1/8	3.2	14	350
5/32	4.0	14 or 18	350 or 450
3/16	—	14 or 18	—
—	5.0	—	350 or 450
7/32	—	14 or 18 or 28	—
—	6.0	—	350 or 450 or 700
1/4	—	18 or 28	—
5/16	8.0	18 or 28	450 or 700

^a Lengths and sizes other than these shall be as agreed between purchaser and supplier.

^b In all cases, end-gripped electrodes are standard.

^c ISO 544 *Welding consumables — Technical delivery conditions for welding filler materials — Type of product, dimensions, tolerances and markings.* See 20.2 for tolerances on diameter and length.

21. Core Wire and Covering

21.1 The core wire and covering shall be free of defects that would interfere with uniform deposition of the electrode.

21.2 The core wire and the covering shall be concentric to the extent that the maximum core-plus-one-covering dimension shall not exceed the minimum core-plus-one-covering dimension by more than:

- (1) 7% of the mean dimension in sizes 3/32 in [2.5 mm] and smaller;
- (2) 5% of the mean dimension in sizes 1/8 in [3.2 mm] and 5/32 in [4.0 mm];
- (3) 4% of the mean dimension in sizes 3/16 in [5.0 mm] and larger.

Concentricity may be measured by any suitable means.

22. Exposed Core

22.1 The grip end of each electrode shall be bare (free of covering) for a distance of not less than 1/2 in [12 mm], nor more than 1-1/4 in [30 mm] for 5/32 in [4.0 mm] and smaller sizes, and not less than 3/4 in [20 mm] nor more than 1-1/2 in [40 mm] for 3/16 in [5.0 mm] and larger sizes, to provide for electrical contact with the electrode holder.

22.2 The arc end of each electrode shall be sufficiently conductive and the covering sufficiently tapered to permit easy striking of the arc. The length of the conductive portion (measured from the end of the core wire to the location where the full cross-section of the covering is obtained) shall not exceed 1/8 in [3.2 mm] or the diameter of the core wire, whichever is less. Electrodes with chipped coverings near the arc end, baring the core wire no more than the lesser of 1/4 in [6.0 mm] or twice the diameter of the core wire, meet the requirements of this specification, provided no chip uncovers more than 50% of the circumference of the core.

23. Electrode Identification

All electrodes shall be identified as follows:

23.1 At least one imprint of the electrode designation (classification plus any optional designators) shall be applied to the electrode covering in the order specified in Figure 10, starting within 2-1/2 in [65 mm] of the grip end of the electrode. The prefix letter "E" in the classification may be omitted from the imprint.

23.2 The numbers and letters of the imprint shall be of bold block type of a size large enough to be legible.

23.3 The ink used for imprinting shall provide sufficient contrast with the electrode covering so that, in normal use, the numbers and letters are legible both before and after welding.

23.4 When an electrode is classified as meeting the requirements of A5.1 and A5.1M, both electrode designations shall be applied.

24. Packaging

24.1 Electrodes shall be suitably packaged to protect them from damage during shipment and storage under normal conditions. In addition, E7018M [E4918M] electrodes shall be packaged in hermetically sealed containers. These hermetically sealed containers shall be capable of passing the test specified in 24.3.

24.2 Standard package weights shall be as agreed between purchaser and supplier.

24.3 Hermetically sealed containers may be tested by selecting a representative sample container and immersing in water that is at a temperature of at least 50°F [30°C] above that of the packaged material (room temperature). The container shall be immersed so that the surface under observation is one inch [25 mm] below the water level and the greatest basic dimension of the container is parallel to the surface of the water. A "leaker" is indicated by a steady stream of air bubbles emanating from the container. A container with a stream that lasts for 30 seconds or more does not meet the requirements of this specification.

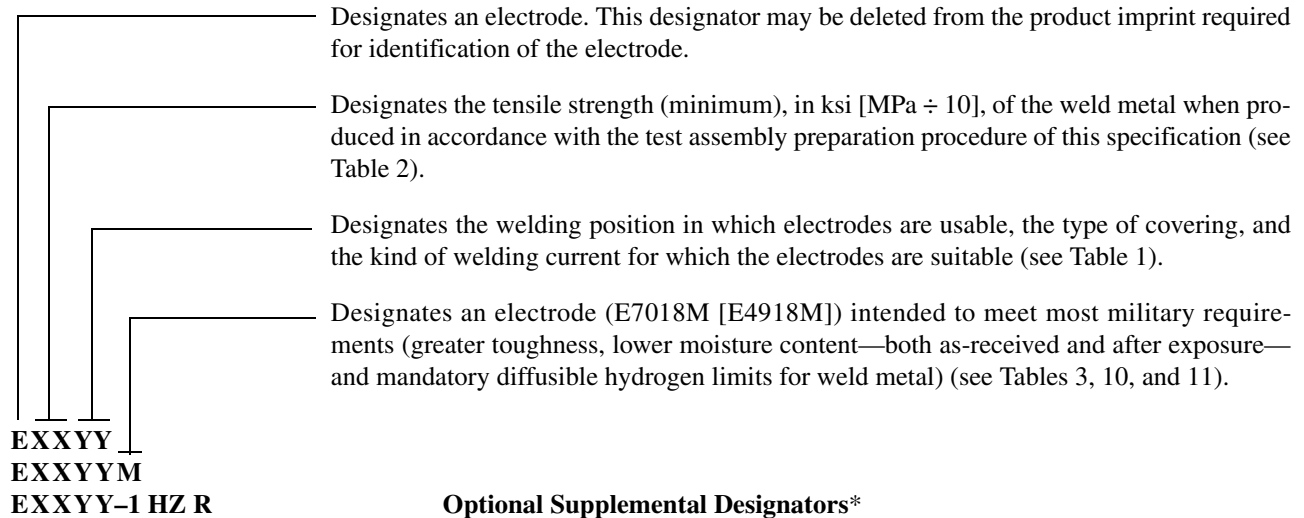
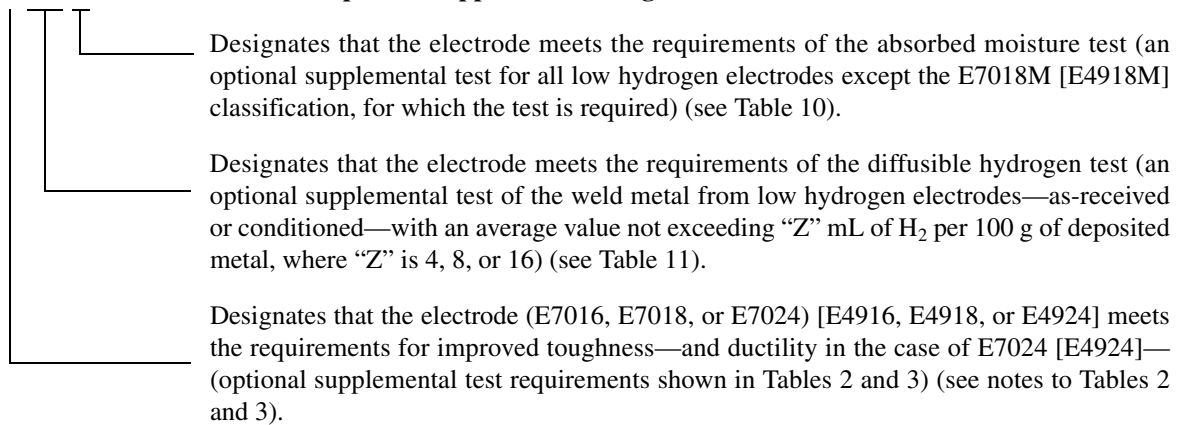
Mandatory Classification Designators***Optional Supplemental Designators***

*The combination of these designators constitutes the electrode classification.

Figure 10—Order of Mandatory and Optional Supplemental Designators

25. Marking of Packages

25.1 The following product information (as a minimum) shall be legibly marked on the outside of each unit package:

- (1) AWS specification and classification designations along with applicable optional designators (year of issue may be excluded)
- (2) Supplier’s name and trade designation
- (3) Size and net weight
- (4) Lot, control, or heat number.

25.2 The appropriate precautionary information⁸ as given in ANSI Z49.1, latest edition, (as a minimum) or its equivalent, shall be prominently displayed in legible print on all packages of electrodes, including individual unit packages enclosed within a larger package.

⁸Typical examples of “warning labels” are shown in figures in ANSI Z49.1 for some common or specific consumables used with certain processes.

This page is intentionally blank.

Annex A (Informative)

Guide to AWS Specification for Carbon Steel Electrodes for Shielded Metal Arc Welding

This annex is not part of AWS A5.1/A5.1M:2012, *Specification for Carbon Steel Electrodes for Shielded Metal Arc Welding*, but is included for informational purposes only.

A1. Introduction

The purpose of this guide is to correlate the electrode classifications with their intended applications so the specification can be used effectively. Appropriate base metal specifications are referred to whenever that can be done and when it would be most helpful. Such references are intended only as examples rather than complete listings of the base metals for which each electrode classification is suitable.

A2. Classification System

A2.1 The system for identifying the electrode classifications in this specification follows the standard pattern used in other AWS filler metal specifications. The prefix letter “E” at the beginning of each classification designation stands for electrode. The first two digits, 60 [43], for example, designate tensile strength of at least 60 ksi [430 MPa] of the weld metal, produced in accordance with the test assembly preparation section of the specification. In this document, the classification in U.S. Customary Units is followed by the SI Unit classification in brackets. The third digit designates position usability that will allow satisfactory welds to be produced with the electrode.

Thus, the “1,” as in E6010 [E4310], means that the electrode is usable in all positions (flat, horizontal, vertical, and overhead). The “2,” as in E6020 [E4320] designates that the electrode is suitable for use in the flat position and for making fillet welds in the horizontal position. The “4,” as in E7048 [E4948], designates that the electrode is suitable for use in vertical welding with downward progression and for other positions (see Table 1). The last two digits taken together designate the type of current with which the electrode can be used and the type of covering on the electrode, as listed in Table 1.

A2.2 Optional designators are also used in this specification in order to identify electrodes that have met the mandatory classification requirements and certain supplementary requirements as agreed to between the supplier and the purchaser. A “-1” designator following classification identifies an electrode which meets optional supplemental impact requirements at a lower temperature than required for the classification (see Note b to Table 3). An example of this is the E7024-1 [E4924-1] electrode which meets the classification requirements of E7024 [E4924] and also meets the optional supplemental requirements for toughness and improved elongation of the weld metal (see Note e to Table 2).

Certain low-hydrogen electrodes also may have optional designators. An optional supplemental designator “HZ” following the four digit classification designators or following the “-1” optional supplemental designator, if used, indicates an average diffusible hydrogen content of not more than “Z” mL/100g of deposited metal when tested in the “as-received” or conditioned state in accordance with AWS A4.3, *Standard Methods for Determination of the Diffusible Hydrogen Content of Martensitic, Bainitic, and Ferritic Steel Weld Metal Produced by Arc Welding*. Electrodes that are designated as meeting the lower or lowest hydrogen limits, as specified in Table 11, are also understood to be able to meet any

higher hydrogen limits even though these are not necessarily designated along with the electrode classification. Therefore, as an example, an electrode designated as “H4” also meets “H8” and “H16” requirements without being designated as such. See Clause 18, Diffusible Hydrogen Test, and Table 11.

A letter “R” is a designator used with the low-hydrogen electrode classifications. It is used to identify electrodes that have been exposed to a humid environment for a given length of time and tested for moisture absorption in addition to the standard moisture test required for classification of low-hydrogen electrodes (see Clause 17, Absorbed Moisture Test, and Table 10).

A2.3 Table A.1 shows the classification for similar electrodes from Canadian Standards Association standard W48-01, *Filler Metals and Allied Materials for Metal Arc Welding*.

A2.4 Request for Filler Metal Classification

A2.4.1 When a welding electrode cannot be classified according to some classification given in this specification, the manufacturer may request that a classification be established for that welding electrode. The manufacturer may do this by following the procedure given in A2.4.3, below.

A2.4.2 A request to establish a new electrode classification must be a written request, and it needs to provide sufficient detail to permit the Committee on Filler Metals and Allied Materials, or the Subcommittee, to determine whether a new classification or the modification of an existing classification is more appropriate, and whether either is necessary to satisfy the need.

A2.4.3 In particular, the request needs to include:

(1) All classification requirements as given for existing classifications, such as, chemical composition ranges, mechanical property requirements, and usability test requirements.

Table A.1
Canadian Electrode Classifications
Similar to AWS Classifications

Canadian Electrode Classification ^a	A5.1	A5.1M
E4310	E6010	E4310
E4311	E6011	E4311
E4312	E6012	E4312
E4313	E6013	E4313
E4322	E6022	E4322
E4327	E6027	E4327
E4910	—	—
E4911	—	—
E4912	—	—
E4913	—	—
E4914	E7014	E4914
E4915	E7015	E4915
E4916	E7016	E4916
E4918 ^b	E7018	E4918
E4922	—	—
E4924 ^c	E7024	E4924
E4927	E7027	E4927
E4928	E7028	E4928
E4948	E7048	E4948

^a From CSA Standard W48-01, *Filler Metals and Allied Materials for Metal Arc Welding*, published by Canadian Standards Association, 178 Rexdale Boulevard, Rexdale, Ontario, Canada M9W 1R3.

^b Also includes E4918-1 designated electrode.

^c Also includes E4924-1 designated electrodes.

(2) Any testing conditions for conducting the tests used to demonstrate that the product meets the classification requirements. (It would be sufficient, for example, to state that the welding conditions are the same as for the other classifications.)

(3) Information on Descriptions and Intended Use, which parallels that for existing classifications, for that section of the annex.

(4) Proposed ASME “F” number, if appropriate.

A request for a new classification without the above information will be considered incomplete. The Secretary will return the request to the requestor for further information.

A2.4.4 The request should be sent to the Secretary of the Committee on Filler Metals and Allied Materials at AWS Headquarters. Upon receipt of the request, the Secretary will:

(1) Assign an identifying number to the request. The number shall include the date the request was received.

(2) Confirm receipt of the request, and give the identification number to the person making the request.

(3) Send a copy of the request to the Chair of the Committee on Filler Metals and Allied Materials, and the Chair of the particular Subcommittee involved.

(4) File the original request.

(5) Add the request to the log of outstanding requests.

A2.4.5 All necessary action on each request shall be completed as soon as possible. If more than 12 months elapse, the Secretary shall inform the requestor of the status of the request, with copies to the Chairs of the Committee and Subcommittee. Requests still outstanding after 18 months shall be considered not to have been answered in a timely manner and the Secretary shall report these to the Chair of the Committee on Filler Metals and Allied Materials, for action.

A2.4.6 The Secretary shall include a copy of the log of all requests pending and those completed during the preceding year with the agenda for each Committee on Filler Metals and Allied Materials meeting. Any other publication of requests that have been completed will be at the option of the American Welding Society, as deemed appropriate.

A2.5 An international system for designating welding filler metals developed by the International Institute of Welding (IIW) is being adopted in many ISO specifications. Table A.2 shows those used in ISO 2560 for comparison with the classifications in this specification. To understand the proposed international designation system, one is referred to Table 1 and the annex of AWS document IFS:2002, entitled *International Index of Welding Filler Metal Classifications*. National specifications from many industrial countries having comparable filler metals are also found in Table 1 of IFS:2002.

A3. Acceptance

Acceptance of all welding materials classified under this specification is in accordance with AWS A5.01M/A5.01 (ISO 14344 MOD), as the specification states. Any testing a purchaser requires of the supplier, for material shipped in accordance with this specification, needs to be clearly stated in the purchase order, according to the provisions of AWS A5.01. In the absence of any such statement in the purchase order, the supplier may ship the material with whatever testing the supplier normally conducts on material of that classification, as specified in Schedule F, Table 1, of the AWS A5.01. Testing in accordance with any other schedule in that table must be properly required by the purchase order. In such cases, acceptance of the material shipped shall be in accordance with those requirements.

A4. Certification

The act of placing the AWS Specification and Classification designations and optional supplemental designators, if applicable, on the packaging enclosing the product or the classification on the product itself, constitutes the supplier’s (manufacturer’s) certification that the product meets all of the requirements of the specification.

Table A.2
Comparison of Equivalent Classifications^a

A	ISO 2560 ^b	B	A5.1	USA AWS	A5.1M
E35xC21		E4310	E6010		E4310
E35xC11		E4311	E6011		E4311
E35xR12		E4312	E6012		E4312
E35xR12		E4313	E6013		E4313
—		E4318	E6018		E4318
E35xRA12		E4319	E6019		E4319
E35xA13		E4320	E6020		E4320
E35xA33		—	E6022		E4322
E35xRA54		E4327	E6027		E4327
E38xR32		E4914	E7014		E4914
E38xB22		E4915	E7015		E4915
E38xB12		E4916	E7016		E4916
—		E4916-1	E7016-1		E4916-1
E38xB32		E4918	E7018		E4918
—		E4918-1	E7018-1		E4918-1
—		—	E7018M		E4918M
E38xRR4		E4924	E7024		E4924
E38xRR4		E4924-1	E7024-1		E4924-1
E38xRA54		E4927	E7027		E4927
E38xB53		E4928	E7028		E4928
E38xB35		E4948	E7048		E4948

^a The requirements for the equivalent classifications are not necessarily identical in every respect.

^b ISO 2560, *Welding consumables — Covered electrodes for manual metal arc welding of nonalloy fine grain steels — Classification*.

The only testing requirement implicit in this certification is that the manufacturer has actually conducted the tests required by the specification on material that is representative of that being shipped and that the material met the requirements of the specification. Representative material, in this case, is any production run of that classification using the same formulation. “Certification” is not to be construed to mean that tests of any kind were necessarily conducted on samples of the specific material shipped. Tests on such material may or may not have been made. The basis for the certification required by the specification is the classification test of “representative material” cited above, and the “Manufacturer’s Quality Assurance Program” in AWS A5.01M/A5.01 (ISO 14344 MOD).

A5. Ventilation During Welding

A5.1 The following five major factors govern the quantity of fumes in the atmosphere to which welders and welding operators are exposed during welding:

- (1) Dimensions of the space in which welding is done (with special regard to the height of the ceiling)
- (2) Number of welders and welding operators working in that space
- (3) Rate of evolution of fumes, gases, or dust, according to the materials and processes used
- (4) The proximity of welders and welding operators to the fumes as they issue from the welding zone, and to the gases and dust in the space in which they are working
- (5) The ventilation provided to the space in which the welding is done.

A5.2 American National Standard ANSI Z49.1, *Safety in Welding, Cutting, and Allied Processes* (published by the American Welding Society), discusses the ventilation that is required during welding and should be referred to for details. Attention is drawn particularly to the section of that document entitled, "Health Protection and Ventilation."

A6. Welding Considerations

A6.1 Weld metal properties may vary widely, according to size of the electrode and amperage used, size of the weld beads, base metal thickness, joint geometry, preheat and interpass temperatures, surface condition, base metal composition, dilution, etc. Because of the profound effect of these variables, a test procedure was chosen for this specification which would represent good welding practice and minimize variation of the most potent of these variables.

A6.2 It should be recognized, however, that production practices may be different. The differences encountered may alter the properties of the weld metal. For instance, interpass temperatures may range from subfreezing to several hundred degrees. No single temperature or reasonable range of temperatures can be chosen for classification tests which will be representative of all of the conditions encountered in production work.

Properties of production welds may vary accordingly, depending on the particular welding conditions. Weld metal properties may not duplicate, or even closely approach, the values listed and prescribed for test welds. For example, ductility in single pass welds in thick base metal made outdoors in cold weather without adequate preheating may drop to little more than half that required herein and normally obtained. This does not indicate that either the electrodes or the welds are below standard. It indicates only that the particular production conditions are more severe than the test conditions prescribed by this specification.

A6.3 Hydrogen is another factor to be considered in welding. Weld metals, other than those from low-hydrogen electrodes (E7015 [E4915], E7016 [E4916], E7018 [E4918], E7018M [E4918M], E7028 [E4928], and E7048 [E4948]) contain significant quantities of hydrogen for some period of time after they have been made. Most of this hydrogen gradually escapes. After two to four weeks at room temperature or 24 hours to 48 hours at 200°F to 220°F [90°C to 105°C], most of it has escaped. As a result of this change in hydrogen content, ductility of the weld metal increases towards its inherent value, while yield, tensile and impact strengths remain relatively unchanged.

This specification permits aging of the test specimens at 200°F to 220°F [90°C to 105°C] for up to 48 hours before subjecting them to the all-weld-metal tension or transverse bend test. This is done to minimize discrepancies in testing (see also A8.2, Diffusible Hydrogen Test).

A6.4 When weldments are given a postweld heat treatment, the temperature and time at temperature are very important. The tensile and yield strengths generally are decreased as postweld heat treatment temperature and time at temperature are increased.

A6.5 Welds made with electrodes of the same classification and the same welding procedure will have significantly different tensile and yield strengths in the as-welded and postweld heat-treated conditions. Comparison of the values for as-welded and postweld heat-treated (1150°F [620°C] for one hour) weld metal will show the following:

A6.5.1 The tensile strength of the postweld heat-treated weld metal will be approximately 5 ksi [35 MPa] lower than that of the weld metal in the as-welded condition.

A6.5.2 The yield strength of the postweld heat-treated weld metal will be approximately 10 ksi [70 MPa] lower than that of the weld metal in the as-welded condition.

A6.6 Conversely, postweld heat-treated welds made with the same electrodes and using the same welding procedure except for variation in interpass temperature and postweld heat treatment time, can have almost identical tensile and yield strengths. As an example, almost identical tensile and yield strengths may be obtained in two welds, one using an interpass temperature of 300°F [150°C] and postweld heat-treated for 1 hour at 1150°F [620°C], and the other using an interpass temperature of 212°F [100°C] and postweld heat-treated for 10 hours at 1150°F [620°C].

A6.7 Electrodes which meet all the requirements of any given classification may be expected to have similar characteristics. Certain minor differences continue to exist from one brand to another due to differences in preferences that exist regarding specific operating characteristics. Furthermore, the only differences between the present E60XX and E70XX [E43XX and E49XX] classifications are the differences in chemical composition and mechanical properties of the weld metal, as shown in Tables 2, 3, and 7. In many applications, electrodes of either E60XX or E70XX [E43XX or E49XX] classifications may be used.

A6.8 Since the electrodes within a given classification have similar operating characteristics and mechanical properties, the user can limit the study of available electrodes to those within a single classification after determining which classification best suits the particular requirements.

A6.9 This specification does not establish values for all characteristics of the electrodes falling within a given classification, but it does establish values to measure those of major importance. In some instances, a particular characteristic is common to a number of classifications and testing for it is not necessary. In other instances, the characteristics are so intangible that no adequate tests are available. This specification does not necessarily provide all the information needed to determine which classification will best fulfill a particular need. The information included in Annex Clause A7 regarding typical applications for each classification supplements information given elsewhere in the specification and is intended to provide assistance in making electrode selections. However, it must be noted that it is the fabricator's responsibility to ensure that the electrode selected will satisfy all of the performance requirements for the intended applications under the specific fabrication conditions in use.

A6.10 Some important tests for measuring major electrode characteristics are as follows:

A6.10.1 Radiographic Test. Nearly all of the carbon steel electrodes covered by this specification are capable of producing welds that meet most radiographic soundness requirements. However, if incorrectly applied, unsound welds may be produced by any of the electrodes. For electrodes of some classifications, the radiographic requirements in Table 8 are not necessarily indicative of the average radiographic soundness to be expected in production use. Electrodes of the E6010 [E4310], E6011 [E4311], E6019 [E4319], and E6020 [E4320] classifications can be expected to produce acceptable radiographic results.

Under certain conditions, notably in welding long, continuous joints in relatively thick base metal, low-hydrogen electrodes of the E7015 [E4915], E7016 [E4916], E7018 [E4918], and E7018M [E4918M] classifications will often produce even better results. On the other hand, in joints open to the atmosphere on the root side, at the ends of joints, in joints with many stops and starts, and in welds on small diameter pipe or in small, thin, irregularly shaped joints, the low-hydrogen electrodes tend to produce welds of poor radiographic soundness. For the shielded metal arc process, E6013 [E4313] electrodes usually produce the best radiographic soundness in welding small, thin parts.

E6027 [E4327], E7024 [E4924], and E7028 [E4928] electrodes produce welds which may be either quite good or rather inferior in radiographic soundness. The tendency seems to be in the latter direction. Of all types, the E6022 [E4322] and E6012 [E4312] electrodes generally produce welds with the least favorable radiographic soundness.

A6.10.2 Fillet Weld Test. This test is included as a means of demonstrating the usability of an electrode. This test is concerned with the appearance of the weld (i.e., weld face contour and smoothness, undercut, overlap, size, and resistance to cracking). It also provides an excellent and inexpensive method of determining the adequacy of fusion at the weld root (one of the important considerations for an electrode).

A6.10.3 Toughness. Charpy V-notch impact requirements are included in the specification. All classes of electrodes in the specification can produce weld metal of sufficient toughness for many applications. The inclusion of impact requirements for certain electrode classifications allows the specification to be used as a guide in selecting electrodes where low-temperature toughness is required. There can be considerable variation in the weld metal toughness unless particular attention is given to the welding procedure and the preparation and testing of the specimens. The impact energy values are for Charpy V-notch specimens and should not be confused with values obtained with other toughness tests.

A6.11 Electrode Covering Moisture Content and Conditioning

A6.11.1 Hydrogen can have adverse effects on welds in some steels under certain conditions. One source of this hydrogen is moisture in the electrode coverings. For this reason, the proper storage, treatment, and handling of electrodes are necessary.

A6.11.2 Electrodes are manufactured to be within acceptable moisture limits, consistent with the type of covering and strength of the weld metal. They are then normally packaged in a container which has been designed to provide the degree of moisture protection considered necessary for the type of covering involved.

A6.11.3 If there is a possibility that the noncellulosic electrodes may have absorbed excessive moisture, they may be restored by rebaking. Some electrodes require rebaking at a temperature as high as 800°F [425°C] for approximately 1 hour to 2 hours. The manner in which the electrodes have been produced and the relative humidity and temperature conditions under which the electrodes are stored determine the proper length of time and temperature used for conditioning. Some typical storage and drying conditions are included in Table A.3.

A6.11.4 Cellulosic coverings for E6010 [E4310] and E6011 [E4311] electrodes need moisture levels of approximately 3% to 7% for proper operation; therefore, storage or conditioning above ambient temperature may dry them too much and adversely affect their operation (see Table A.3).

A6.12 Core Wire. The core wire for all the electrodes classified in the specification is usually a mild steel having a typical composition which may differ significantly from that of the weld metal produced by the covered electrodes.

A6.13 Coverings

A6.13.1 Electrodes of some classifications have substantial quantities of iron powder added to their coverings. The iron powder fuses with the core wire and the other metals in the covering, as the electrode melts, and is deposited as part of the weld metal, just as is the core wire. Relatively high currents can be used since a considerable portion of the electrical energy passing through the electrode is used to melt the thicker covering containing iron powder. The result is that more weld metal may be obtained from a single electrode with iron powder in its covering than from a single electrode of the same diameter without iron powder.

A6.13.2 Due to the thick covering and deep cup produced at the arcing end of the electrode, iron powder electrodes can be used very effectively with a “drag” technique. This technique consists of keeping the electrode covering in contact with the workpiece at all times, which makes for easy handling. However, a technique using a short arc length is preferable if the 3/32 in or 1/8 in [2.5 mm or 3.2 mm] electrodes are to be used in other than flat or horizontal fillet welding positions or for making groove welds.

A6.13.3 The E70XX [E49XX] electrodes were included in this specification to acknowledge the higher strength levels obtained with many of the iron powder and low-hydrogen electrodes, as well as to recognize the industry demand for

Table A.3
Typical Storage and Drying Conditions for Covered Arc Welding Electrodes

AWS Classification		Storage Conditions ^{a, b}		
A5.1	A5.1M	Ambient Air	Holding Ovens	Drying Conditions ^c
E6010, E6011	E4310, E4311	Ambient Temperature	Not recommended	Not recommended
E6012, E6013, E6019, E6020, E6022, E6027, E7014, E7024, E7027	E4312, E4313, E4319, E4320, E4322, E4327, E4914, E4924, E4927	80°F ± 20°F [30°C ± 10°C] 50% max. relative humidity	20°F to 40°F [10°C to 20°C] above ambient temperature	275°F ± 25°F [135°C ± 15°C] 1 hour at temperature
E6018, E7015, E7016, E7018, E7028, E7018M, E7048	E4318, E4915 E4916, E4918, E4928, E4918M, E4948	Not recommended	50°F to 250°F [30°C to 140°C] above ambient temperature	500°F to 800°F [260°C to 425°C] 1 to 2 hours at temperature

^a After removal from manufacturer's packaging.

^b Some of these electrode classifications may be designated as meeting low moisture absorbing requirements. This designation does not imply that storage in ambient air is recommended.

^c Because of inherent differences in covering composition, the manufacturers should be consulted for the exact drying conditions.

electrodes with 70 ksi [490 MPa] minimum tensile strength. Unlike the E70XX-X [E49XX-X] classification in AWS A5.5, *Specification for Low-Alloy Steel Electrodes for Shielded Metal Arc Welding*, these electrodes do not contain deliberate alloy additions, nor are they required to meet minimum tensile properties after postweld heat treatment.

A6.13.4 E70XX [E49XX] low-hydrogen electrodes have mineral coverings which are high in limestone and other ingredients that are low in moisture and hence produce weld deposits “low in hydrogen content.” Low-hydrogen electrodes were developed for welding low-alloy high-strength steels, some of which were high in carbon content. Electrodes with other than low-hydrogen coverings may produce “hydrogen-induced cracking” in those steels. These under-bead cracks occur in the base metal, usually just below the weld bead. Weld metal cracks may also occur.

Low-hydrogen electrodes should be used when welding high-sulfur or enameling steels. Other electrodes are likely to cause porosity and/or cracks in high-sulfur steels. With enameling steels, the hydrogen that escapes after welding with other than low-hydrogen electrodes produces holes in the enamel.

A6.14 Amperage Ranges. Table A.4 gives amperage ranges which are satisfactory for most classifications. When welding vertically upward, currents near the lower limit of the range are generally used.

A7. Description and Intended Use of Electrodes

A7.1 E6010 [E4310] Classification

A7.1.1 E6010 [E4310] electrodes are characterized by a deeply penetrating, forceful, spray type arc and readily removable, thin, friable slag which may not seem to completely cover the weld bead. Fillet welds usually have a relatively flat weld face and have a rather coarse, unevenly spaced ripple. The coverings are high in cellulose, usually exceeding 30% by weight. The other materials generally used in the covering include titanium dioxide, metallic deoxidizers such as ferromanganese, various types of magnesium or aluminum silicates, and liquid sodium silicate as a binder. Because of their covering composition, these electrodes are generally described as the high-cellulose sodium type.

A7.1.2 These electrodes are recommended for all welding positions, particularly on multiple pass applications in the vertical and overhead welding positions and where welds of good soundness are required. They frequently are selected for joining pipe and generally are capable of welding in the vertical position with either uphill or downhill progression.

A7.1.3 The majority of applications for these electrodes is in joining carbon steel. However, they have been used to advantage on galvanized steel and on some low-alloy steels. Typical applications include shipbuilding, buildings, bridges, storage tanks, piping, and pressure vessel fittings. Since the applications are so widespread, a discussion of each is impractical. Sizes larger than 3/16 in [5.0 mm] generally have limited use in other than flat or horizontal-fillet welding positions.

A7.1.4 These electrodes have been designed for use with dcep (electrode positive). The maximum amperage that can generally be used with the larger sizes of these electrodes is limited in comparison to that for other classifications due to the high spatter loss that occurs with high amperage.

A7.2 E6011 [E4311] Classification

A7.2.1 E6011 [E4311] electrodes are designed to be used with ac current and to duplicate the usability characteristics and mechanical properties of the E6010 [E4310] classification. Although also usable with dcep (electrode positive), a decrease in joint penetration will be noted when compared to the E6010 [E4310] electrodes. Arc action, slag, and fillet weld appearance are similar to those of the E6010 [E4310] electrodes.

A7.2.2 The coverings are also high in cellulose and are described as the high-cellulose potassium type. In addition to the other ingredients normally found in E6010 [E4310] coverings, small quantities of calcium and potassium compounds usually are present.

A7.2.3 Sizes larger than 3/16 in [5.0 mm] generally have limited use in other than flat or horizontal-fillet welding positions.

Table A.4
Typical Amperage Ranges

Electrode Diameter	E6010, E6011		E6012		E6013		E6019		E6020		E6022		E6027, E7027		E7014		E7015, E7016		E6018, E7018M, E7018		E7024, E7028		E7048			
	A5.1	A5.1M	A5.1	A5.1M	A5.1	A5.1M	A5.1	A5.1M	A5.1	A5.1M	A5.1	A5.1M	A5.1	A5.1M	A5.1	A5.1M	A5.1	A5.1M	A5.1	A5.1M	A5.1	A5.1M	A5.1	A5.1M	A5.1	A5.1M
1/16	1.6	—	—	—	20 to 40	20 to 40	—	—	—	—	—	—	—	—	—	—	—	—	—	—	—	—	—	—	—	—
5/64	2.0	—	—	—	25 to 60	25 to 60	35 to 55	—	—	—	—	—	—	—	—	—	—	—	—	—	—	—	—	—	—	—
3/32 ^a	2.4 ^a , 2.5 ^a	40 to 80	—	—	45 to 90	45 to 90	50 to 90	—	—	—	—	—	—	—	—	—	—	—	—	—	—	—	—	—	—	—
1/8	3.2	75 to 125	80 to 140	—	80 to 130	80 to 130	80 to 140	100 to 150	110 to 160	125 to 185	—	—	—	—	—	—	—	—	—	—	—	—	—	—	—	—
5/32	4.0	110 to 170	110 to 190	—	105 to 180	105 to 180	130 to 190	130 to 190	140 to 190	160 to 240	—	—	—	—	—	—	—	—	—	—	—	—	—	—	—	—
3/16	5.0	140 to 215	140 to 240	—	150 to 230	150 to 230	190 to 250	175 to 250	170 to 400	210 to 300	—	—	—	—	—	—	—	—	—	—	—	—	—	—	—	—
7/32	5.6	170 to 250	200 to 320	—	210 to 300	210 to 300	240 to 310	225 to 310	370 to 520	250 to 350	—	—	—	—	—	—	—	—	—	—	—	—	—	—	—	—
1/4	6.0	210 to 320	250 to 400	—	250 to 350	250 to 350	310 to 360	275 to 375	—	300 to 420	—	—	—	—	—	—	—	—	—	—	—	—	—	—	—	—
5/16	8.0	275 to 425	300 to 500	—	320 to 430	320 to 430	360 to 410	340 to 450	—	375 to 475	—	—	—	—	—	—	—	—	—	—	—	—	—	—	—	—

^a This diameter is not manufactured in the E7028 [E4828] classification.

A7.3 E6012 [E4312] Classification

A7.3.1 E6012 [E4312] electrodes are characterized by low penetrating arc and dense slag, which completely covers the bead. This may result in incomplete root penetration in fillet welded joints. The coverings are high in titania, usually exceeding 35% by weight, and usually are referred to as the “titania” or “rutile” type. The coverings generally also contain small amounts of cellulose and ferromanganese, and various siliceous materials such as feldspar and clay with sodium silicate as a binder. Also, small amounts of certain calcium compounds may be used to produce satisfactory arc characteristics on dcen (electrode negative).

A7.3.2 Fillet welds tend to have a convex weld face with smooth even ripples in the horizontal welding position, and widely spaced rougher ripples in the vertical welding position which become smoother and more uniform as the size of the weld is increased. Ordinarily, a larger size fillet must be made in the vertical and overhead welding positions using E6012 [E4312] electrodes compared to welds with E6010 [E4310] and E6011 [E4311] electrodes of the same diameter.

A7.3.3 The E6012 [E4312] electrodes are all-position electrodes and usually are suitable for welding in the vertical welding position with either the upward or downward progression. However, more often the larger sizes are used in the flat and horizontal welding positions rather than in the vertical and overhead welding positions. The larger sizes are often used for single pass, high-speed, high current fillet welds in the horizontal welding position. Their ease of handling, good fillet weld face, and ability to bridge wide root openings under conditions of poor fit, and to withstand high amperages make them very well suited to this type of work. The electrode size used for vertical and overhead position welding is frequently one size smaller than would be used with an E6010 [E4310] or E6011 [E4311] electrode.

A7.3.4 Weld metal from these electrodes is generally lower in ductility and may be higher in yield strength (1 ksi to 2 ksi [7 MPa to 14 MPa]) than weld metal from the same size of either the E6010 [E4310] or E6011 [E4311] electrodes.

A7.4 E6013 [E4313] Classification

A7.4.1 E6013 [E4313] electrodes, although very similar to the E6012 [E4312] electrodes, have distinct differences. Their flux covering makes slag removal easier and gives a smoother arc transfer than E6012 [E4312] electrodes. This is particularly the case for the small diameters 1/16 in, 5/64 in, and 3/32 in [1.6 mm, 2.0 mm, and 2.5 mm]. This permits satisfactory operation with lower open-circuit ac voltage. E6013 [E4313] electrodes were designed specifically for light sheet metal work. However, the larger diameters are used on many of the same applications as E6012 [E4312] electrodes and provide low penetrating arc. The smaller diameters provide a less penetrating arc than is obtained with E6012 [E4312] electrodes. This may result in incomplete penetration in fillet welded joints.

A7.4.2 Coverings of E6013 [E4313] electrodes contain rutile, cellulose, ferromanganese, potassium silicate as a binder, and other siliceous materials. The potassium compounds permit the electrodes to operate with ac at low amperages and low open-circuit voltages.

A7.4.3 E6013 [E4313] electrodes are similar to the E6012 [E4312] electrodes in usability characteristics and bead appearance. The arc action tends to be quieter and the bead surface smoother with a finer ripple. The usability characteristics of E6013 [E4313] electrodes vary slightly from brand to brand. Some are recommended for sheet metal applications where their ability to weld satisfactorily in the vertical welding position with downward progression is an advantage.

Others, with a more fluid slag, are used for horizontal fillet welds and other general purpose welding. These electrodes produce a flat fillet weld face rather than the convex weld face characteristic of E6012 [E4312] electrodes. They are also suitable for making groove welds because of their concave weld face and easily removable slag. In addition, the weld metal is definitely freer of slag and oxide inclusions than E6012 [E4312] weld metal and exhibits better soundness. Welds with the smaller diameter E6013 [E4313] electrodes often meet the Grade 1 radiographic requirements of this specification.

A7.4.4 E6013 [E4313] electrodes usually cannot withstand the high amperages that can be used with E6012 [E4312] electrodes in the flat and horizontal welding positions. Amperages in the vertical and overhead positions, however, are similar to those used with E6012 [E4312] electrodes.

A7.5 E7014 [E4914] Classification

A7.5.1 E7014 [E4914] electrode coverings are similar to those of E6012 [E4312] and E6013 [E4313] electrodes, but with the addition of iron powder for obtaining higher deposition efficiency. The covering thickness and the amount of iron powder in E7014 [E4914] are less than in E7024 [E4924] electrodes (see A7.10).

A7.5.2 The iron powder also permits the use of higher amperages than are used for E6012 [E4312] and E6013 [E4313] electrodes. The amount and character of the slag permit E7014 [E4914] electrodes to be used in all positions.

A7.5.3 The E7014 [E4914] electrodes are suitable for welding carbon and low alloy steels. Typical weld beads are smooth with fine ripples. Joint penetration is approximately the same as that obtained with E6012 [E4312] electrodes (see A7.3.1), which is advantageous when welding over a wide root opening due to poor fit. The face of fillet welds tends to be flat to slightly convex. The slag is easy to remove. In many cases, it removes itself.

A7.6 Low-Hydrogen Electrodes

A7.6.1 Electrodes of the low-hydrogen classifications E6018 [E4318], E7015 [E4915], E7016 [E4916], E7018 [E4918], E7018M [E4918M], E7028 [E4928], and E7048 [E4948]) are made with inorganic coverings that contain minimal moisture. The covering moisture test such as specified in AWS A4.4M, *Standard Procedure for Determination of Moisture Content of Welding Fluxes and Welding Electrode Flux Coverings*, converts hydrogen-bearing compounds in any form in the covering into water vapor that is collected and measured. The test thus assesses the potential hydrogen available from an electrode covering. All low-hydrogen electrodes, in the as-manufactured condition or after conditioning, are expected to meet a maximum covering moisture limit of 0.6% or less, as required in Table 10.

A7.6.2 The relative potential of an electrode to contribute to diffusible hydrogen in the weld metal can be assessed more directly, but less conveniently, by the diffusible hydrogen test, as specified in Clause 18. The results of this test, using electrodes in the as-manufactured condition or after conditioning, permit the addition of an optional supplemental diffusible hydrogen designator to the classification designation according to Table 11 (see also A8.2 in this annex).

A7.6.3 In order to maintain low-hydrogen electrodes with minimal moisture in their coverings, these electrodes should be stored and handled with considerable care. Electrodes which have been exposed to humidity may absorb considerable moisture and their low-hydrogen character may be lost. Then conditioning can restore their low-hydrogen character (see Table A.3).

A7.6.4 Low-hydrogen electrode coverings can be designed to resist moisture absorption for a considerable time in a humid environment. The absorbed moisture test (see Clause 17) assesses this characteristic by determining the covering moisture after nine hours exposure to 80°F [27°C], 80% relative humidity air. If, after this exposure, the covering moisture does not exceed 0.4%, then the optional supplemental designator, “R,” may be added to the electrode classification designation, as specified in Table 10 (see also A8.3 in this annex).

A7.6.5 E7015 [E4915] Classification

A7.6.5.1 E7015 [E4915] electrodes are low-hydrogen electrodes to be used with dcep (electrode positive). The slag is chemically basic.

A7.6.5.2 E7015 [E4915] electrodes are commonly used for making small welds on thick base metal, since the welds are less susceptible to cracking (see A6.13.4). They are also used for welding high-sulfur and enameling steels. Welds made with E7015 [E4915] electrodes on high-sulfur steels may produce a very tight slag and a very rough or irregular bead appearance in comparison to welds with the same electrodes in steels of normal sulfur content.

A7.6.5.3 The arc of E7015 [E4915] electrodes is moderately penetrating. The slag is heavy, friable, and easy to remove. The weld face is convex, although a fillet weld face may be flat.

A7.6.5.4 E7015 [E4915] electrodes up to and including the 5/32 in [4.0 mm] size are used in all welding positions. Larger electrodes are used for groove welds in the flat welding position and fillet welds in the horizontal and flat welding positions.

A7.6.5.5 Amperages for E7015 [E4915] electrodes are higher than those used with E6010 [E4310] electrodes of the same diameter. The shortest possible arc length should be maintained for best results with E7015 [E4915] electrodes. This reduces the risk of porosity. The necessity for preheating is reduced; therefore, better welding conditions are provided.

A7.6.6 E7016 [E4916] Classification

A7.6.6.1 E7016 [E4916] electrodes have all the characteristics of E7015 [E4915] electrodes, plus the ability to operate on ac. The core wire and coverings are very similar to those of E7015 [E4915], except for the use of a potassium silicate binder or other potassium salts in the coverings to facilitate their use with ac. Most of the preceding discussion on E7015 [E4915] electrodes applies equally well to the E7016 [E4916] electrodes. The discussion in A6.13.4 also applies.

A7.6.6.2 Electrodes designated as E7016-1 [E4916-1] have the same usability and weld metal composition as E7016 [E4916] electrodes except that the manganese content is set at the high end of the range. They are intended for welds requiring a lower transition temperature than is normally available from E7016 [E4916] electrodes.

A7.6.7 E6018 [E4318] and E7018 [E4918] Classifications

A7.6.7.1 E7018 [E4918] electrode coverings are similar to E7015 [E4915] coverings, except for the addition of a relatively high percentage of iron powder. The coverings on these electrodes are slightly thicker than those of the E7016 [E4916] electrodes.

A7.6.7.2 E7018 [E4918] low-hydrogen electrodes can be used with either ac or dcep. They are designed for the same applications as the E7016 [E4916] electrodes. As is common with all low-hydrogen electrodes, a short arc length should be maintained at all times.

A7.6.7.3 In addition to their use on carbon steel, the E7018 [E4918] electrodes are also used for joints involving high-strength, high-carbon, or low-alloy steels (see also A6.13). The fillet welds made in the horizontal and flat welding positions have a slightly convex weld face, with a smooth and finely rippled surface. The electrodes are characterized by a smooth, quiet arc, very low spatter, and medium arc penetration. E7018 [E4918] electrodes can be used at high travel speeds.

A7.6.7.4 Electrodes designated as E7018-1 [E4918-1] have the same usability and weld metal composition as E7018 [E4918] electrodes, except that the manganese content is set at the high end of the range. They are intended for welds requiring a lower transition temperature than is normally available from E7018 [E4918] electrodes.

A7.6.7.5 E6018 [E4318] electrodes possess operating and mechanical property characteristics similar to E7018 [E4918] except at a lower strength level. The electrode covering and low hydrogen characteristics are also similar. This electrode is desirable where matching or undermatching weld deposit is required. Electrodes that meet this classification may also be suitable for buffer layer application in cladding operations.

A7.6.8 E7018M [E4918M] Classification

A7.6.8.1 E7018M [E4918M] electrodes are similar to E7018-1H4R [E4918-1H4R] electrodes, except that the testing for mechanical properties and for classification is done on a groove weld that has a 60° included angle and, for electrodes up to 5/32 in [4.0 mm], welded in the vertical position with upward progression. The impact test results are evaluated using all five test values and higher values are required at -20°F [-30°C]. The maximum allowable moisture-in-coating values in the “as-received” or reconditioned state are more restrictive than that required for E7018R [E4918R]. This classification closely corresponds to MIL-7018-M in the United States military standard MIL-E-22200/10 specification, with the exception that the absorbed moisture limits on the electrode covering and the diffusible hydrogen limits on the weld metal are not as restrictive as those in MIL-E-22200/10.

A7.6.8.2 E7018M [E4918M] is intended to be used with dcep type current in order to produce the optimum mechanical properties. However, if the manufacturer desires, the electrode may also be classified as E7018 [E4918] provided all the requirements of E7018 [E4918] are met.

A7.6.8.3 In addition to their use on carbon steel, the E7018M [E4918M] electrodes are used for joining carbon steel to high-strength low-alloy steels and higher carbon steels. Fillet welds made in the horizontal and flat welding positions have a slightly convex weld face, with a smooth and finely rippled surface. The electrodes are characterized by a smooth, quiet arc, very low spatter, and medium arc penetration.

A7.6.9 E7028 [E4928] Classification

A7.6.9.1 E7028 [E4928] electrodes are very much like the E7018 [E4918] electrodes. However, E7028 [E4928] electrodes are suitable for fillet welds in the horizontal welding position and groove welds in the flat welding position only, whereas E7018 [E4918] electrodes are suitable for all positions.

A7.6.9.2 The E7028 [E4928] electrode coverings are much thicker. They make up approximately 50% of the weight of the electrodes. The iron content of E7028 [E4928] electrodes is higher (approximately 50% of the weight of the coverings). Consequently, on fillet welds in the horizontal position and groove welds in the flat welding position, E7028 [E4928] electrodes give a higher deposition rate than the E7018 [E4918] electrodes for a given size of electrode.

A7.6.10 E7048 [E4948] Classification. Electrodes of the E7048 [E4948] classification have the same usability, composition, and design characteristics as E7018 [E4918] electrodes, except that E7048 [E4948] electrodes are specifically designed for exceptionally good vertical welding with downward progression (see Table 1).

A7.7 E6019 [E4319] Classification

A7.7.1 E6019 [E4319] electrodes, although very similar to E6013 and E6020 [E4313 and E4320] electrodes in their coverings, have distinct differences. E6019 [E4319] electrodes, with a rather fluid slag system, provide deeper arc penetration and produce weld metal that meets a 22% minimum elongation requirement, meets the Grade 1 radiographic standards, and has an average impact strength of 20 ft-lbf [27J] when tested at 0°F [–20°C].

A7.7.2 E6019 [E4319] electrodes are suitable for multipass welding of up to 1 in [25 mm] thick steel. They are designed for use with ac, dcen, or dcep. While 3/16 in [5.0 mm] and smaller diameter electrodes can be used for all welding positions (except vertical welding position with downward progression), the use of larger diameter electrodes should be limited to the flat or horizontal fillet welding position. When welding in the vertical welding position with upward progression, weaving should be limited to minimize undercut.

A7.8 E6020 [E4320] Classification

A7.8.1 E6020 [E4320] electrodes have a high iron oxide covering. They are characterized by a spray type arc, produce a smooth and flat or slightly concave weld face, and have an easily removable slag.

A7.8.2 A low viscosity slag limits their usability to horizontal fillets and flat welding positions. With arc penetration ranging from medium to deep (depending upon welding current), E6020 [E4320] electrodes are best suited for thicker base metal.

A7.9 E6022 [E4322] Classification. Electrodes of the E6022 [E4322] classification are recommended for single-pass, high-speed, high-current welding of groove welds in the flat welding position, lap joints in the horizontal welding position, and fillet welds on sheet metal. The weld face tends to be more convex and less uniform, especially since the welding speeds are higher.

A7.10 E7024 [E4924] Classification

A7.10.1 E7024 [E4924] electrode coverings contain large amounts of iron powder in combination with ingredients similar to those used in E6012 and E6013 [E4312 and E4313] electrodes. The coverings on E7024 [E4924] electrodes are very thick and usually amount to about 50% of the weight of the electrode, resulting in higher deposition efficiency.

A7.10.2 The E7024 [E4924] electrodes are well suited for making fillet welds in the flat or horizontal position. The weld face is slightly convex to flat, with a very smooth surface and a very fine ripple. These electrodes are characterized by a smooth, quiet arc, very low spatter, and low arc penetration. They can be used with high travel speeds. Electrodes of these classifications can be operated on ac, dcep, or dcen.

A7.10.3 Electrodes designated as E7024-1 [E4924-1] have the same general usability characteristics as E7024 [E4924] electrodes. They are intended for use in situations requiring greater ductility and a lower transition temperature than normally is available from E7024 [E4924] electrodes.

A7.11 E6027 [E4327] Classification

A7.11.1 E6027 [E4327] electrode coverings contain large amounts of iron powder in combination with ingredients similar to those found in E6020 [E4320] electrodes. The coverings on E6027 [E4327] electrodes are also very thick and usually amount to about 50% of the weight of the electrode.

A7.11.2 The E6027 [E4327] electrodes are designed for fillet or groove welds in the flat welding position with ac, dcep, or dcen, and will produce a flat or slightly concave weld face on fillet welds in the horizontal position with either ac or dcen.

A7.11.3 E6027 [E4327] electrodes have a spray-type arc. They will operate at high travel speeds. Arc penetration is medium. Spatter loss is very low. E6027 [E4327] electrodes produce a heavy slag which is honeycombed on the underside. The slag is friable and easily removed.

A7.11.4 Welds produced with E6027 [E4327] electrodes have a flat to slightly concave weld face with a smooth, fine, even ripple, and good wetting along the sides of the joint. The weld metal may be slightly inferior in radiographic soundness to that from E6020 [E4320] electrodes. High amperages can be used, since a considerable portion of the electrical energy passing through the electrode is used to melt the covering and the iron powder it contains. These electrodes are well suited for thicker base metal.

A7.12 E7027 [E4927] Classification. E7027 [E4927] electrodes have the same usability and design characteristics as E6027 [E4327] electrodes, except they are intended for use in situations requiring slightly higher tensile and yield strengths than are obtained with E6027 [E4327] electrodes. They must also meet chemical composition requirements (see Table 7). In other respects, all previous discussions for E6027 [E4327] electrodes also apply to E7027 [E4927] electrodes.

A8. Special Tests

A8.1 It is recognized that supplementary tests may be necessary to determine the suitability of these welding electrodes for applications involving properties not considered in this specification. In such cases, additional tests to determine specific properties, such as hardness, corrosion resistance, mechanical properties at higher or lower service temperatures, wear resistance, and suitability for welding combinations of different carbon and low alloy steels, may need to be conducted.

A8.2 Diffusible Hydrogen Test

A8.2.1 Hydrogen-induced cracking of weld metal or the heat-affected-zone generally is not a problem with carbon steels containing 0.3% or less carbon, nor with lower strength alloy steels. However, the electrodes classified in this specification are sometimes used to join higher carbon steels or low-alloy high-strength steels where hydrogen-induced cracking may be a serious problem.

A8.2.2 The coating moisture test has proven to be a satisfactory test over many years as a means of assessing the degree of care needed to avoid hydrogen-induced cracking. This is, however, an indirect test. Moisture itself does not cause cracking, but the diffusible hydrogen that forms from the moisture in the arc can cause cracking. Nor is moisture the only source of hydrogen.

A8.2.3 Since entry of diffusible hydrogen into the weld pool can be affected by the form of the moisture in the coating (for example, chemically bonded versus surface adsorbed), there is a fundamental utility for considering diffusible hydrogen for low-hydrogen electrodes. Accordingly, the use of optional designators for diffusible hydrogen is introduced to indicate the maximum average value obtained under a clearly defined test condition in AWS A4.3, *Standard Methods for Determination of the Diffusible Hydrogen Content of Martensitic, Bainitic, and Ferritic Steel Weld Metal Produced by Arc Welding*.

A8.2.4 The user of this information is cautioned that actual fabrication conditions may result in different diffusible hydrogen values than those indicated by the designator.

A8.2.5 The use of a reference atmospheric condition during welding is necessitated because the arc is imperfectly shielded. Moisture from the air, distinct from that in the covering, can enter the arc and subsequently the weld pool, contributing to the resulting observed diffusible hydrogen. This effect can be minimized by maintaining as short an arc length as possible consistent with a steady arc. Experience has shown that the effect of arc length is minor at H16 level, but can be very significant at the H4 level. An electrode meeting the H4 requirements under the reference atmospheric conditions may not do so under conditions of high humidity at the time of welding, especially if a long arc length is maintained.

A8.2.6 The reference atmospheric condition during welding of the test assembly is 10 grains of water vapor per pound of dry air [1.43 g of water vapor per kg of dry air]. This corresponds to 70°F [21°C] and 10% RH on a standard psychrometric chart at 29.92 in [760 mm] Hg barometric pressure. Actual conditions, measured using a sling psychrometer, that equal or exceed this reference condition provide assurance that the conditions during welding will not diminish the final results of the test.

A8.3 Absorbed Moisture Test. The development of low-hydrogen electrode coverings that resist moisture absorption during exposure to humid air is a recent improvement in covered electrode technology. Not all commercial low-hydrogen

electrodes possess this characteristic. To assess this characteristic, the absorbed moisture test described in Clause 17 was devised. The exposure conditions selected for the test are arbitrary. Other conditions may yield quite different results.

A task group of the AWS A5A Subcommittee evaluated this test and concluded that it can successfully differentiate moisture resistant electrodes from those which are not. The task group also observed considerable variability of covering moisture results after exposure of electrodes in cooperative testing among several laboratories. The precision of the test is such that, with moisture resistant electrodes from a single lot, the participating laboratories could observe exposed covering moisture values ranging, for example, from 0.15% or less to 0.35% or more. The task group concluded that the variability was due to both variations in the exposure conditions and the variability inherent in the application of the moisture test procedure. Therefore, it is not realistic to set a limit for covering moisture of exposed moisture resistant electrodes lower than 0.4% at this time.

A9. Discontinued Classifications

A number of electrode classifications have been discontinued during the numerous revisions of this specification, reflecting either changes in commercial practice, or changes in the scope of filler metals classified in the specification. These discontinued electrode classifications are listed in Table A.5, along with the year they were last published in this specification.

A10. General Safety Considerations

NOTE: Safety and health issues and concerns are beyond the scope of this standard and, therefore, are not fully addressed herein. Some safety and health information can be found in Annex Clause A5. Safety and health information is available from other sources, including, but not limited to, Safety and Health Fact Sheets listed in A10.2, ANSI Z49.1, *Safety in Welding, Cutting, and Allied Processes*,⁹ and applicable federal and state regulations.

⁹ ANSI Z49.1 is published by the American Welding Society, 8669 Doral Blvd., Doral, FL 33166.

Table A.5
Discontinued Electrode Classifications^a

AWS Classification	Last A5.1 (ASTM A-233) Publication Date	AWS Classification	Last A5.1 (ASTM A-233) Publication Date
E4511	1943	E9030	1945
E4521	1943	E10010 ^b	1945
E7010 ^b	1945	E10011 ^b	1945
E7011 ^b	1945	E10012	1945
E7012	1945	E10020	1945
E7020 ^b	1945	E10030	1945
E7030	1945	E4510	1958
E8010 ^b	1945	E4520	1958
E8011 ^b	1945	E6014	1958
E8012	1945	E6015	1958
E8020 ^b	1945	E6016	1958
E8030	1945	E6018 ^c	1958
E9010 ^b	1945	E6024	1958
E9011 ^b	1945	E6028	1958
E9012	1945	E6030	1958
E9020	1945		

^a See Clause A9 for information on discontinued classifications.

^b These electrode classifications were transferred from the ASTM A233-45T to the new AWS A5.5-48T. They were later discontinued from that specification and replaced with the new "G" classifications in order to permit a single classification system with weld metal chemical composition requirements in AWS A5.5-58T.

^c This classification was reintroduced in the 2004 revision of AWS A5.1/A5.1M with revised classification requirements.

A10.1 Safety and Health Fact Sheets. The Safety and Health Fact Sheets listed below are published by the American Welding Society (AWS). They may be downloaded and printed directly from the AWS website at <http://www.aws.org>. The Safety and Health Fact Sheets are revised and additional sheets added periodically.

A10.2 AWS Safety and Health Fact Sheets Index (SHF)¹⁰

No.	Title
1	<i>Fumes and Gases</i>
2	<i>Radiation</i>
3	<i>Noise</i>
4	<i>Chromium and Nickel in Welding Fume</i>
5	<i>Electrical Hazards</i>
6	<i>Fire and Explosion Prevention</i>
7	<i>Burn Protection</i>
8	<i>Mechanical Hazards</i>
9	<i>Tripping and Falling</i>
10	<i>Falling Objects</i>
11	<i>Confined Spaces</i>
12	<i>Contact Lens Wear</i>
13	<i>Ergonomics in the Welding Environment</i>
14	<i>Graphic Symbols for Precautionary Labels</i>
15	<i>Style Guidelines for Safety and Health Documents</i>
16	<i>Pacemakers and Welding</i>
17	<i>Electric and Magnetic Fields (EMF)</i>
18	<i>Lockout/Tagout</i>
19	<i>Laser Welding and Cutting Safety</i>
20	<i>Thermal Spraying Safety</i>
21	<i>Resistance Spot Welding</i>
22	<i>Cadmium Exposure from Welding & Allied Processes</i>
23	<i>California Proposition 65</i>
24	<i>Fluxes for Arc Welding and Brazing: Safe Handling and Use</i>
25	<i>Metal Fume Fever</i>
26	<i>Arc Viewing Distance</i>
27	<i>Thoriated Tungsten Electrodes</i>
28	<i>Oxyfuel Safety: Check Valves and Flashback Arrestors</i>
29	<i>Grounding of Portable and Vehicle Mounted Welding Generators</i>
30	<i>Cylinders: Safe Storage, Handling, and Use</i>
31	<i>Eye and Face Protection for Welding and Cutting Operations</i>
33	<i>Personal Protective Equipment (PPE) for Welding & Cutting</i>
34	<i>Coated Steels: Welding and Cutting Safety Concerns</i>
36	<i>Ventilation for Welding & Cutting</i>
37	<i>Selecting Gloves for Welding & Cutting</i>

¹⁰ AWS standards are published by the American Welding Society, 8669 Doral Blvd., Doral, FL 33166.

Annex B (Informative)

Guidelines for the Preparation of Technical Inquiries

This annex is not part of AWS A5.1/A5.1M:2012, *Specification for Carbon Steel Electrodes for Shielded Metal Arc Welding*, but is included for informational purposes only.

B1. Introduction

The American Welding Society (AWS) Board of Directors has adopted a policy whereby all official interpretations of AWS standards are handled in a formal manner. Under this policy, all interpretations are made by the committee that is responsible for the standard. Official communication concerning an interpretation is directed through the AWS staff member who works with that committee. The policy requires that all requests for an interpretation be submitted in writing. Such requests will be handled as expeditiously as possible, but due to the complexity of the work and the procedures that must be followed, some interpretations may require considerable time.

B2. Procedure

All inquiries shall be directed to:

Managing Director
Technical Services Division
American Welding Society
8669 Doral Blvd.
Doral, FL 33166

All inquiries shall contain the name, address, and affiliation of the inquirer, and they shall provide enough information for the committee to understand the point of concern in the inquiry. When the point is not clearly defined, the inquiry will be returned for clarification. For efficient handling, all inquiries should be typewritten and in the format specified below.

B2.1 Scope. Each inquiry shall address one single provision of the standard unless the point of the inquiry involves two or more interrelated provisions. The provision(s) shall be identified in the scope of the inquiry along with the edition of the standard that contains the provision(s) the inquirer is addressing.

B2.2 Purpose of the Inquiry. The purpose of the inquiry shall be stated in this portion of the inquiry. The purpose can be to obtain an interpretation of a standard's requirement or to request the revision of a particular provision in the standard.

B2.3 Content of the Inquiry. The inquiry should be concise, yet complete, to enable the committee to understand the point of the inquiry. Sketches should be used whenever appropriate, and all paragraphs, figures, and tables (or annex) that bear on the inquiry shall be cited. If the point of the inquiry is to obtain a revision of the standard, the inquiry shall provide technical justification for that revision.

B2.4 Proposed Reply. The inquirer should, as a proposed reply, state an interpretation of the provision that is the point of the inquiry or provide the wording for a proposed revision, if this is what the inquirer seeks.

B3. Interpretation of Provisions of the Standard

Interpretations of provisions of the standard are made by the relevant AWS technical committee. The secretary of the committee refers all inquiries to the chair of the particular subcommittee that has jurisdiction over the portion of the standard addressed by the inquiry. The subcommittee reviews the inquiry and the proposed reply to determine what the response to the inquiry should be. Following the subcommittee's development of the response, the inquiry and the response are presented to the entire committee for review and approval. Upon approval by the committee, the interpretation is an official interpretation of the Society, and the secretary transmits the response to the inquirer and to the *Welding Journal* for publication.

B4. Publication of Interpretations

All official interpretations will appear in the *Welding Journal* and will be posted on the AWS web site.

B5. Telephone Inquiries

Telephone inquiries to AWS Headquarters concerning AWS standards should be limited to questions of a general nature or to matters directly related to the use of the standard. The AWS *Board Policy Manual* requires that all AWS staff members respond to a telephone request for an official interpretation of any AWS standard with the information that such an interpretation can be obtained only through a written request. Headquarters staff cannot provide consulting services. However, the staff can refer a caller to any of those consultants whose names are on file at AWS Headquarters.

B6. AWS Technical Committees

The activities of AWS technical committees regarding interpretations are limited strictly to the interpretation of provisions of standards prepared by the committees or to consideration of revisions to existing provisions on the basis of new data or technology. Neither AWS staff nor the committees are in a position to offer interpretive or consulting services on (1) specific engineering problems, (2) requirements of standards applied to fabrications outside the scope of the document, or (3) points not specifically covered by the standard. In such cases, the inquirer should seek assistance from a competent engineer experienced in the particular field of interest.

AWS Filler Metal Specifications by Material and Welding Process

	OFW	SMAW	GTAW GMAW PAW	FCAW	SAW	ESW	EGW	Brazing
Carbon Steel	A5.2	A5.1	A5.18, A5.36	A5.36	A5.17	A5.25	A5.26	A5.8, A5.31
Low-Alloy Steel	A5.2	A5.5	A5.28, A5.36	A5.36	A5.23	A5.25	A5.26	A5.8, A5.31
Stainless Steel		A5.4	A5.9, A5.22	A5.22	A5.9	A5.9	A5.9	A5.8, A5.31
Cast Iron	A5.15	A5.15	A5.15	A5.15				A5.8, A5.31
Nickel Alloys		A5.11	A5.14	A5.34	A5.14	A5.14		A5.8, A5.31
Aluminum Alloys		A5.3	A5.10					A5.8, A5.31
Copper Alloys		A5.6	A5.7					A5.8, A5.31
Titanium Alloys			A5.16					A5.8, A5.31
Zirconium Alloys			A5.24					A5.8, A5.31
Magnesium Alloys			A5.19					A5.8, A5.31
Tungsten Electrodes			A5.12					
Brazing Alloys and Fluxes								A5.8, A5.31
Surfacing Alloys	A5.21	A5.13	A5.21	A5.21	A5.21			
Consumable Inserts			A5.30					
Shielding Gases			A5.32	A5.32			A5.32	

This page is intentionally blank.

AWS Filler Metal Specifications and Related Documents

Designation	Title
FMC	<i>Filler Metal Comparison Charts</i>
IFS	<i>International Index of Welding Filler Metal Classifications</i>
UGFM	<i>User's Guide to Filler Metals</i>
A4.2M (ISO 8249 MOD)	<i>Standard Procedures for Calibrating Magnetic Instruments to Measure the Delta Ferrite Content of Austenitic and Duplex Ferritic-Austenitic Stainless Steel Weld Metal</i>
A4.3	<i>Standard Methods for Determination of the Diffusible Hydrogen Content of Martensitic, Bainitic, and Ferritic Steel Weld Metal Produced by Arc Welding</i>
A4.4M	<i>Standard Procedures for Determination of Moisture Content of Welding Fluxes and Welding Electrode Flux Coverings</i>
A4.5M/A4.5 (ISO 15792-3 MOD)	<i>Standard Methods for Classification Testing of Positional Capacity and Root Penetration of Welding Consumables in a Fillet Weld</i>
A5.01M/A5.01 (ISO 14344 MOD)	<i>Procurement Guidelines for Consumables—Welding and Allied Processes—Flux and Gas Shielded Electrical Welding Processes</i>
A5.02/A5.02M	<i>Specification for Filler Metal Standard Sizes, Packaging, and Physical Attributes</i>
A5.1/A5.1M	<i>Specification for Carbon Steel Electrodes for Shielded Metal Arc Welding</i>
A5.2/A5.2M	<i>Specification for Carbon and Low-Alloy Steel Rods for Oxyfuel Gas Welding</i>
A5.3/A5.3M	<i>Specification for Aluminum and Aluminum-Alloy Electrodes for Shielded Metal Arc Welding</i>
A5.4/A5.4M	<i>Specification for Stainless Steel Electrodes for Shielded Metal Arc Welding</i>
A5.5/A5.5M	<i>Specification for Low-Alloy Steel Electrodes for Shielded Metal Arc Welding</i>
A5.6/A5.6M	<i>Specification for Copper and Copper-Alloy Electrodes for Shielded Metal Arc Welding</i>
A5.7/A5.7M	<i>Specification for Copper and Copper-Alloy Bare Welding Rods and Electrodes</i>
A5.8/A5.8M	<i>Specification for Filler Metals for Brazing and Braze Welding</i>
A5.9/A5.9M	<i>Specification for Bare Stainless Steel Welding Electrodes and Rods</i>
A5.10/A5.10M (ISO 18273 MOD)	<i>Welding Consumables—Wire Electrodes, Wires and Rods for Welding of Aluminum and Aluminum-Alloys—Classification</i>
A5.11/A5.11M	<i>Specification for Nickel and Nickel-Alloy Welding Electrodes for Shielded Metal Arc Welding</i>
A5.12M/A5.12 (ISO 6848 MOD)	<i>Specification for Tungsten and Oxide Dispersed Tungsten Electrodes for Arc Welding and Cutting</i>
A5.13/A5.13M	<i>Specification for Surfacing Electrodes for Shielded Metal Arc Welding</i>
A5.14/A5.14M	<i>Specification for Nickel and Nickel-Alloy Bare Welding Electrodes and Rods</i>
A5.15	<i>Specification for Welding Electrodes and Rods for Cast Iron</i>
A5.16/A5.16M	<i>Specification for Titanium and Titanium-Alloy Welding Electrodes and Rods</i>
A5.17/A5.17M	<i>Specification for Carbon Steel Electrodes and Fluxes for Submerged Arc Welding</i>
A5.18/A5.18M	<i>Specification for Carbon Steel Electrodes and Rods for Gas Shielded Arc Welding</i>
A5.19	<i>Specification for Magnesium Alloy Welding Electrodes and Rods</i>
A5.21/A5.21M	<i>Specification for Bare Electrodes and Rods for Surfacing</i>
A5.22/A5.22M	<i>Specification for Stainless Steel Flux Cored and Metal Cored Welding Electrodes and Rods</i>
A5.23/A5.23M	<i>Specification for Low-Alloy Steel Electrodes and Fluxes for Submerged Arc Welding</i>
A5.24/A5.24M	<i>Specification for Zirconium and Zirconium-Alloy Welding Electrodes and Rods</i>
A5.25/A5.25M	<i>Specification for Carbon and Low-Alloy Steel Electrodes and Fluxes for Electroslag Welding</i>
A5.26/A5.26M	<i>Specification for Carbon and Low-Alloy Steel Electrodes for Electrogas Welding</i>
A5.28/A5.28M	<i>Specification for Low-Alloy Steel Electrodes and Rods for Gas Shielded Arc Welding</i>
A5.30/A5.30M	<i>Specification for Consumable Inserts</i>
A5.31M/A5.31	<i>Specification for Fluxes for Brazing and Braze Welding</i>
A5.32M/A5.32 (ISO 14175 MOD)	<i>Welding Consumables—Gases and Gas Mixtures for Fusion Welding and Allied Processes</i>
A5.34/A5.34M	<i>Specification for Nickel-Alloy Electrodes for Flux Cored Arc Welding</i>
A5.36/A5.36M	<i>Specification for Carbon and Low-Alloy Steel Flux Cored Electrodes for Flux Cored Arc Welding and Metal Cored Electrodes for Gas Metal Arc Welding</i>

This page is intentionally blank.

